

# HF102F

# MINIATURE HIGH POWER RELAY



File No.:E134517



File No.:40024142



File No.:CQC13002098165



## Features

- 4.5kV dielectric strength (between coil and contacts)
- Heavy load up to 5000VA
- Ideal for motor switching
- PCB & QC layouts available
- UL insulation system: Class F

## CONTACT DATA

Contact arrangement	1A
Contact resistance <sup>1)</sup>	100mΩ max.(at 1A 6VDC)
Contact material	AgSnO <sub>2</sub> , AgCdO
Contact rating	Resistive: 20A 250VAC Motor: 2HP 240VAC
Max. switching voltage	250VAC
Max. switching current	Resistive: 25A
Max. switching power	6250VA
Mechanical endurance	2 x 10 <sup>6</sup> ops
Electrical endurance	1 x 10 <sup>5</sup> ops (20A 250VAC, Resistive load, at 85°C, 1.5s on 1.5s off)

Notes: 1)The data shown above are initial values.

## CHARACTERISTICS

Insulation resistance	1000MΩ (at 500VDC)	
Dielectric strength	Between coil & contacts	4500VAC 1min
	Between open contacts	1000VAC 1min
Operate time (at rated. volt.)	20ms max.	
Release time (at rated. volt.)	10ms max.	
Temperature rise (at rated. volt.)	60K max.	
Shock resistance	Functional	196m/s <sup>2</sup>
	Destructive	980m/s <sup>2</sup>
Vibration resistance	10Hz to 55Hz 1.5mm DA	
Ambient temperature	-25°C to 85°C	
Humidity	5% to 85% RH	
Termination	HF102F: PCB & QC HF102F-P: PCB	
Unit weight	Approx. 23g	
Construction	Dust protected	

Notes: The data shown above are initial values.

## COIL

Coil power	Approx. 900mW
------------	---------------

## COIL DATA

at 23°C

Nominal Voltage VDC	Pick-up Voltage VDC max. 1)	Drop-out Voltage VDC min. 1)	Max. Voltage VDC *2)	Coil Resistance Ω
5	3.5	0.5	6.0	27.8 x (1±10%)
12	8.4	1.2	14.4	160 x (1±10%)
24	16.8	2.4	28.8	640 x (1±10%)
48	33.6	4.8	57.6	2560 x (1±10%)

Notes: 1)The data shown above are initial values.

2)\*Maximum voltage refers to the maximum voltage which relay coil could endure in a short period of time.

## SAFETY APPROVAL RATINGS

UL/CUL	25A 250VAC
	20A 250VAC
	1HP 120VAC
	2HP 240VAC
VDE	25A 250VAC at 55°C
	20A 250VAC at 85°C

Notes: 1) All values unspecified are at room temperature.

2) Only typical loads are listed above. Other load specifications can be available upon request.



HONGFA RELAY

ISO9001, ISO/TS16949, ISO14001, OHSAS18001, IECQ QC 080000 CERTIFIED

2019 Rev. 1.00

## ORDERING INFORMATION

	<b>HF102F /</b>	<b>T</b>	<b>12VDC</b>	<b>(XXX)</b>
<b>Type</b>	HF102F-P: PCB HF102F: PCB & QC			
<b>Contact material</b>	<b>T:</b> AgSnO <sub>2</sub>	<b>Nil:</b> AgCdO		
<b>Coil voltage</b>	5, 12, 24, 48VDC			
<b>Special code<sup>2)</sup></b>	<b>XXX:</b> Customer special requirement	<b>Nil:</b> Standard		

**Notes:** 1) HF102F is dust protected version which cannot be washed.  
2) The customer special requirement express as special code after evaluating by Hongfa.

## OUTLINE DIMENSIONS, WIRING DIAGRAM AND PC BOARD LAYOUT

Unit: mm

### Outline Dimensions

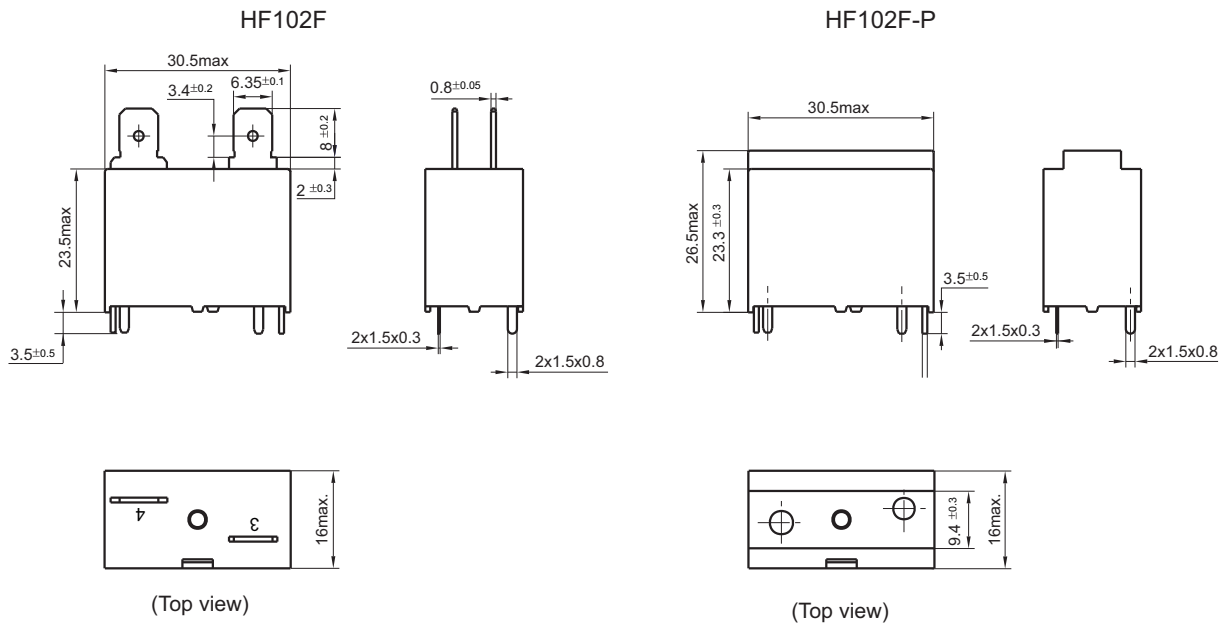

### PCB Layout (Bottom view)

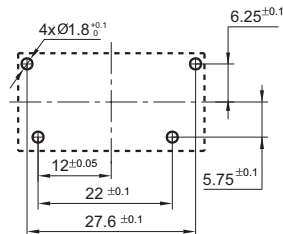

### Wiring Diagram

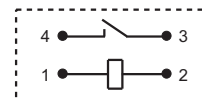

**Remark:** 1) In case of no tolerance shown in outline dimension: outline dimension  $\leq 1\text{mm}$ , tolerance should be  $\pm 0.2\text{mm}$ ; outline dimension  $> 1\text{mm}$  and  $\leq 5\text{mm}$ , tolerance should be  $\pm 0.3\text{mm}$ ; outline dimension  $> 5\text{mm}$ , tolerance should be  $\pm 0.4\text{mm}$ .  
2) The tolerance without indicating for PCB layout is always  $\pm 0.1\text{mm}$ .

## CHARACTERISTIC CURVES

MAXIMUM SWITCHING POWER

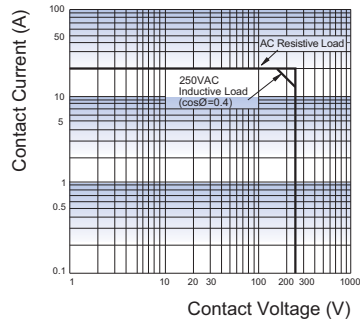

ENDURANCE CURVE

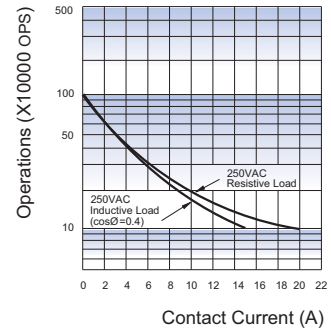

**Test conditions:**

Room temp. 1s on 9s off

### Disclaimer

The specification is for reference only. See to "Terminology and Guidelines" for more information. Specifications subject to change without notice. We could not evaluate all the performance and all the parameters for every possible application. Thus the user should be in a right position to choose the suitable product for their own application. If there is any query, please contact Hongfa for the technical service. However, it is the user's responsibility to determine which product should be used only.