

HF18FZ

MINIATURE INTERMEDIATE POWER RELAY



File No: E133481



File No: 40048406



File No: CQC17002183722



Features

- Multiple switching capability (2C, 4C type)
- With LED
- Conform to the CE low voltage directive
- 2.0kV dielectric strength(between coil and contacts)
- High electrical life
- High mechanical life
- With test button
- Automatic production

CONTACT DATA

Contact arrangement	2C	4C
Contact resistance ¹⁾	100mΩ max.(at 1A 6VDC)	
Contact material	See ordering info.	
Contact rating (Res. load)	7A 220VAC/24VDC	5A 220VAC/24VDC
	5A 220VAC/24VDC	3A 220VAC/24VDC
Max. switching voltage	277VAC / 30VDC	
Max. switching current	7A	5A
Max. switching power	1939VA/ 210W	1385VA/ 150W
Mechanical endurance	5 x 10 ⁷ OPS(DC type)	
	2 x 10 ⁷ OPS(AC type)	
Electrical endurance ²⁾	2Z:1 x 10 ⁵ OPS(7A 277VAC or 7A 30VDC, Resistive load,Room temp.,1s on 9s off)	
	4Z:1 x 10 ⁵ OPS(5A 277VAC or 5A 30VDC, Resistive load,Room temp.,1s on 9s off)	

Notes: 1) The data shown above are initial values.

2) Please refer to the characteristic curves for detailed electrical endurance information.If you need other conditions,please contact us.

CHARACTERISTICS

Insulation resistance	1000MΩ (at 500VDC)	
Dielectric strength	Between coil & contacts	2000VAC 1min
	Between open contacts	1000VAC 1min
	Between contact sets	2000VAC 1min(2Z)
1500VAC 1min(4Z)		
Operate time (at nomi. volt.)	20ms max.	
Release time (at nomi. volt.)	DC type: 15ms max.	
	AC type: 25ms max.	
Temperature rise	85K max.	
Shock resistance	Functional	200m/s ² (NO), 100m/s ² (NC)
	Destructive	1000m/s ²
Vibration resistance	10Hz to 55Hz 1mm DA	
Humidity	5% to 85% RH	
Ambient temperature	-40°C to 70°C	
Termination	Plug-in	
Unit weight	Approx. 39.4g	
Construction	Dust protected	

Notes: 1) The data shown above are initial values.

COIL

Coil power	DC type: Approx. 0.8W to 1.1W; AC type: Approx. 0.9VA to 1.5VA
------------	---

COIL DATA

at 23°C

Nominal Voltage VDC	Pick-up Voltage VDC max. ¹⁾	Drop-out Voltage VDC min.	Max. Voltage VDC ²⁾	Coil Resistance Ω
6	4.8	0.60	6.6	41 x (1±15%)
12	9.6	1.20	13.2	165 x (1±15%)
24	19.2	2.40	26.4	662 x (1±15%)
48	38.4	4.80	52.8	2725 x (1±15%)
100/110	80.0	11.0	110/121	11440 x (1±15%)
220	170.0	22.0	242	53780 x (1±15%)

Nominal Voltage VAC	Pick-up Voltage VAC max. ¹⁾	Drop-out Voltage VAC min.	Max. Voltage VAC ²⁾	Coil Resistance Ω
12	9.60	3.60	13.2	46 x (1±15%)
24	19.2	7.20	26.4	180 x (1±15%)
48	38.4	14.4	52.8	788 x (1±15%)
100/110	80.0	33.0	110/121	3750 x (1±15%)
110/120	88.0	36.0	121/132	4430 x (1±15%)
200/220	160.0	66.0	220/242	12950 x (1±15%)
220/240	176.0	72.0	242/264	15920 x (1±15%)

Notes: 1) Under ambient temperature, applying more than 80% of rating voltage to coil, relay will take action accordingly. But in order to meet the stated product performance, please apply rated voltage to coil.

2) Maximum voltage refers to the maximum voltage which relay coil could endure in a short period of time.



HONGFA RELAY

ISO9001, ISO/TS16949, ISO14001, OHSAS18001, IECQ QC 080000 CERTIFIED

2019 Rev. 1.05

SAFETY APPROVAL RATINGS

UL/CUL	2 Form C	7A 277VAC or 7A 30VDC
	4 Form C	5A 277VAC or 5A 30VDC Resistive at 70°C
CQC	2 Form C	7A 277VAC or 7A 30VDC Resistive at 70°C
	4 Form C	5A 277VAC or 5A 30VDC Resistive at 70°C
VDE	2 Form C	7A 277VAC or 7A 30VDC Resistive at 70°C
	4 Form C	5A 277VAC or 5A 30VDC Resistive at 70°C

Notes: 1) Only typical loads are listed above. Other load specifications can be available upon request.

ORDERING INFORMATION

Type	HF18FZ/	A	12	-2Z	2	3	J	1	G	(XXX)
Coil voltage form	A: AC(50Hz or 60Hz) Nil: DC									
Coil voltage	DC: 6VDC to 220VDC AC: 12VAC to 240VAC									
Contact arrangement	2Z: 2 Form C 4Z: 4 Form C									
Termination	2: Socket									
Contact material	3: AgNi									
Custom component code	Nil: Without Component J: With free-wheeling diode									
Interface function code	1: No LED no button 2: With LED no button 3: With LED and button									
Contact plating	G: Gold-plated Nil: No gold-plated									
Special code ¹⁾	XXX: Customer special requirement Nil: Standard									

Notes: 1) The customer special requirement express as special code after evaluating by Hongfa.

2) As for the nominal voltage less than 110VDC products with continuous diode type product.

Outline Dimensions

HF18FZ/□□□□-2Z2□□□1□
 HF18FZ/□□□□-2Z2□□□2□

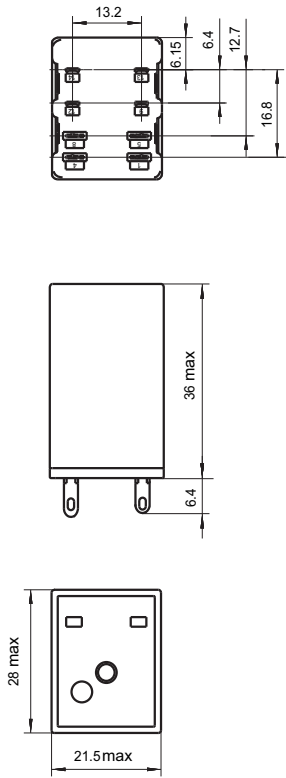

HF18FZ/□□□□-2Z2□□□3□

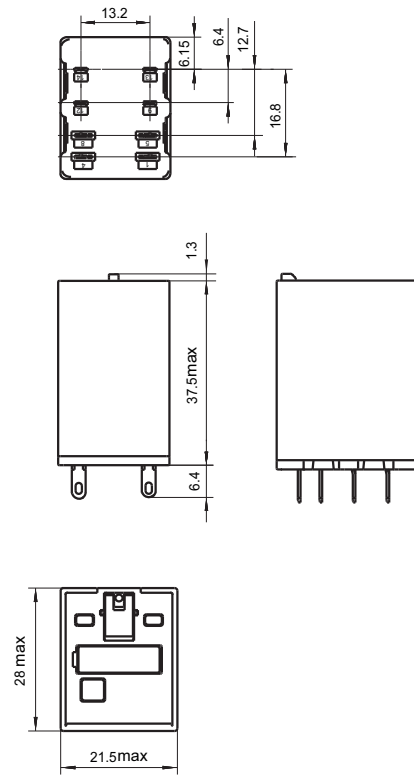

HF18FZ/□□□□-4Z2□□□1□
 HF18FZ/□□□□-4Z2□□□2□

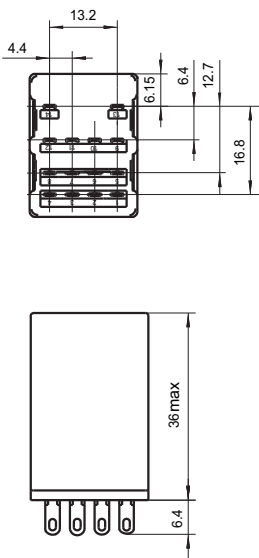

HF18FZ/□□□□-4Z2□□□3□

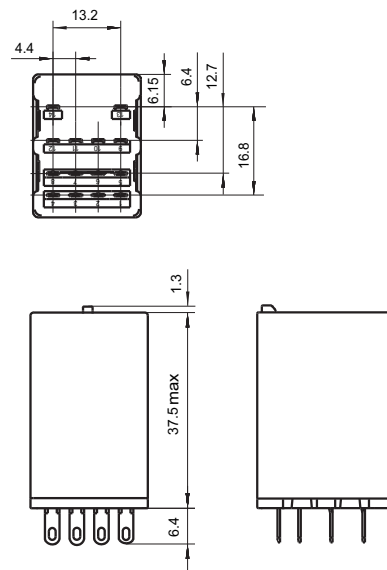

OUTLINE DIMENSIONS

Unit: mm

Outline Dimensions

HF18FZ/□□□□-4Z2□□□1□
 HF18FZ/□□□□-4Z2□□□2□

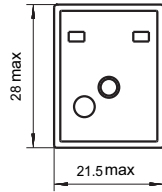

HF18FZ/□□□□-4Z2□□□3□

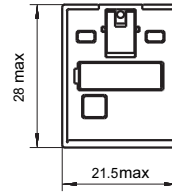

Remark: In case of no tolerance shown in outline dimension: outline dimension $\leq 1\text{mm}$, tolerance should be $\pm 0.2\text{mm}$; outline dimension $> 1\text{mm}$ and $\leq 5\text{mm}$, tolerance should be $\pm 0.3\text{mm}$; outline dimension $> 5\text{mm}$, tolerance should be $\pm 0.4\text{mm}$.

WIRING DIAGRAM(BOTTOM VIEW)

HF18FZ/□□□□-2Z232
 HF18FZ/□□□□-2Z233

2 Form C(DC,With LED)
 (Without 220VDC)

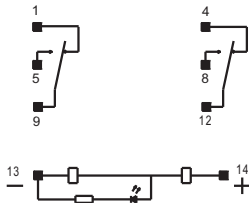

HF18FZ/□□□□-2Z23J2
 HF18FZ/□□□□-2Z23J3

2 Form C
 (DC, With fly-wheel diode and LED)
 (Without 220VDC)

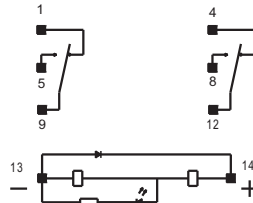

HF18FZ/A□□□-2Z232
 HF18FZ/A□□□-2Z233

2 Form C
 (AC, With LED)

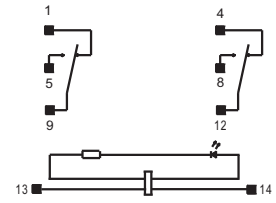

HF18FZ/220-2Z232
 HF18FZ/220-2Z233

2 Form C(DC, With LED)
 (220VDC)

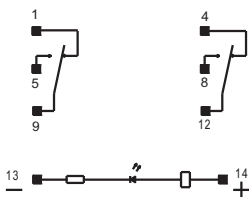

HF18FZ/220-2Z23J2
 HF18FZ/220-2Z23J3

2 Form C
 (DC, With fly-wheel diode and LED)
 (220VDC)

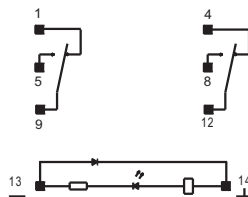

WIRING DIAGRAM(BOTTOM VIEW)

HF18FZ/□□□-4Z232
HF18FZ/□□□-4Z233

4 Form C(DC, With LED)
(Without 220VDC)

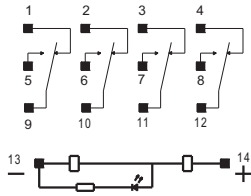

HF18FZ/□□□-4Z23J2
HF18FZ/□□□-4Z23J3

4 Form C
(DC, With fly-wheel diode and LED)
(Without 220VDC)

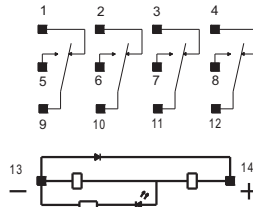

HF18FZ/A□□□-4Z232
HF18FZ/A□□□-4Z233

4 Form C
(AC, With LED)

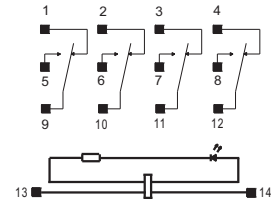

HF18FZ/220-4Z232
HF18FZ/220-4Z233

4 Form C(DC, With LED)
(220VDC)

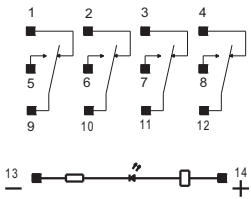

HF18FZ/220-4Z23J2
HF18FZ/220-4Z23J3

4 Form C
(DC, With fly-wheel diode and LED)
(220VDC)

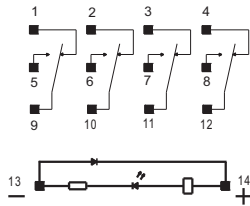

CHARACTERISTIC CURVES

MAXIMUM SWITCHING POWER
(2 Form C)

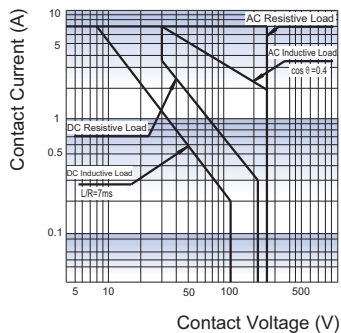

MAXIMUM SWITCHING POWER
(4 Form C)

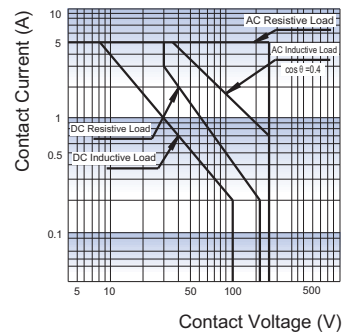

CHARACTERISTIC CURVES

ENDURANCE CURVE
(2 Form C)

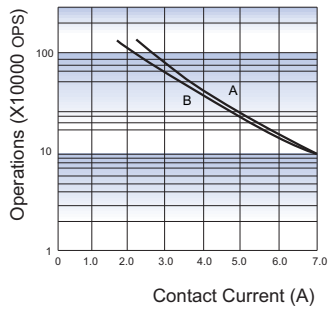

ENDURANCE CURVE
(4 Form C)

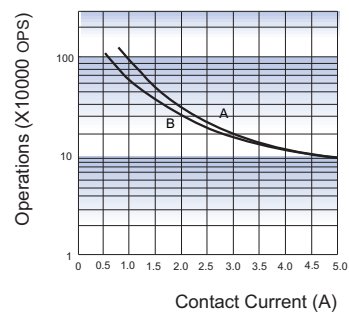

Notes: 1) Line A is Res.load 24Vd.c.
Line B is Res.load 220Va.c.
2) Switching condition:NO or NC.

Relay Sockets



Features

- The dielectric strength can reach 2000VAC and the insulation resistance is 1000MΩ
- Three mounting types are available: PCB mounting screw mounting and DIN rail mounting.
- With finger protection device
- Many kinds of plug-in modules are available with the function of energizing indication and wiring protection.
- Components available: retainer, marker and plug-in module
- Environmental friendly product (RoHS compliant)







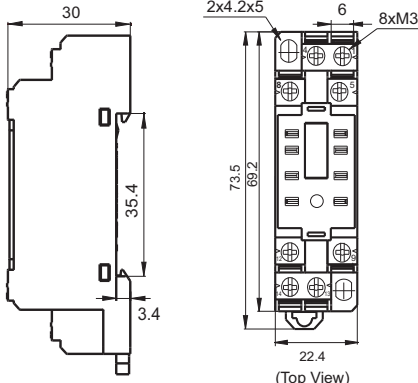
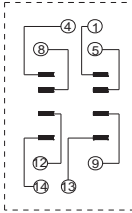
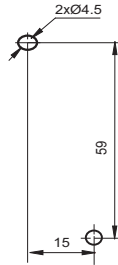

CHARACTERISTICS

Type	Nominal Voltage	Nominal Current	Ambient Temperature	Dielectric Strength min.	Screw Torque	Wire Strip Length	Unit weight
18FZ-2Z-C2	250VAC	7A	-40 °C ~ 70°C	2000VAC	0.6N · m	7mm	Approx.30g
18FZ-4Z-C2	250VAC	5A	-40 °C ~ 70°C	2000VAC	0.6N · m	7mm	Approx.44g
18FF-2Z-A2	250VAC	7A	-40 °C ~ 70°C	2000VAC	—	—	Approx.8g
18FF-2Z-C1	250VAC	7A	-40 °C ~ 70°C	2000VAC	0.8N · m	7mm	Approx.35g
18FF-2Z-C2	250VAC	7A	-40 °C ~ 70°C	2000VAC	0.8N · m	7mm	Approx.36g
18FF-2Z-C4	250VAC	7A	-40 °C ~ 70°C	2000VAC	0.6N · m	7mm	Approx.53g
18FF-2Z-C5	250VAC	7A	-40 °C ~ 70°C	2000VAC	0.6N · m	7mm	Approx.64g
18FF-2Z-C8	250VAC	7A	-40 °C ~ 70°C	2000VAC	0.6N · m	7mm	Approx.41g
18FF-2Z-C9	250VAC	7A	-40 °C ~ 70°C	2000VAC	—	7mm	Approx.70g
18FF-4Z-A2	250VAC	7A*	-40 °C ~ 70°C	2000VAC	—	—	Approx.8g
18FF-4Z-C1	250VAC	7A*	-40 °C ~ 70°C	2000VAC	0.8N · m	7mm	Approx.58g
18FF-4Z-C2	250VAC	7A*	-40 °C ~ 70°C	2000VAC	0.8N · m	7mm	Approx.59g
18FF-4Z-C4	250VAC	7A*	-40 °C ~ 70°C	2000VAC	0.6N · m	7mm	Approx.64g
18FF-4Z-C5	250VAC	7A*	-40 °C ~ 70°C	2000VAC	0.6N · m	7mm	Approx.76g
18FF-4Z-C8	250VAC	7A*	-40 °C ~ 70°C	2000VAC	0.6N · m	7mm	Approx.51g
18FF-4Z-C9	250VAC	7A*	-40 °C ~ 70°C	2000VAC	—	7mm	Approx.81g

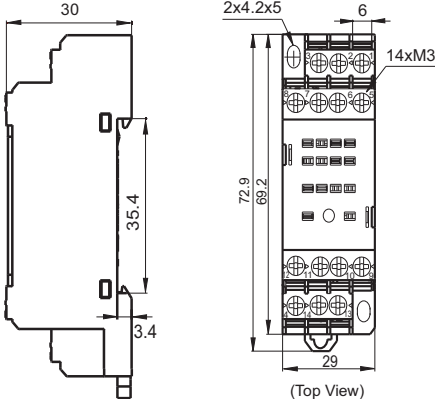
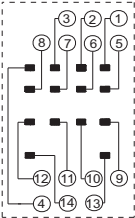
Remark: For sockets marked *, their group of current totally should be not more than 20A.

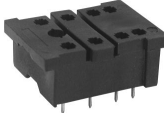
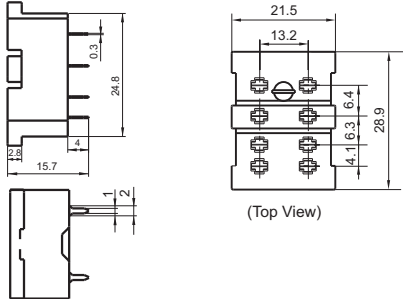
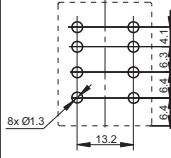

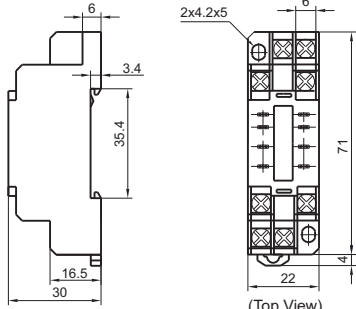
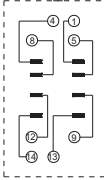
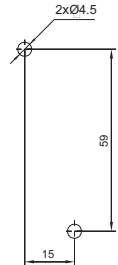

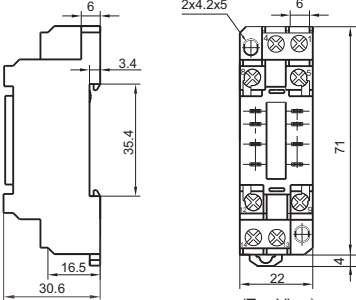
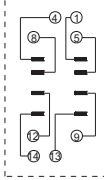
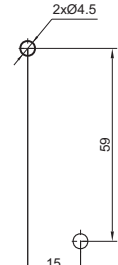

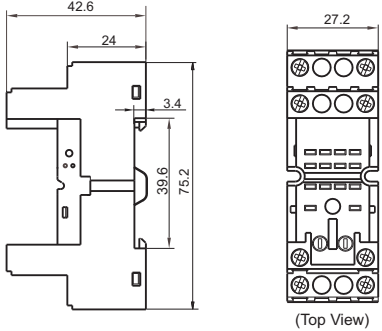
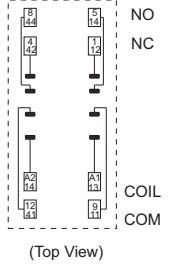
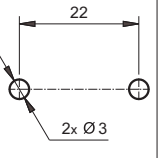

OUTLINE DIMENSIONS, WIRING DIAGRAM AND PC BOARD LAYOUT

Unit: mm

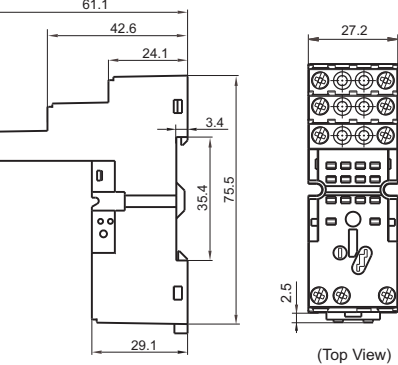
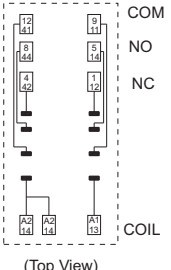
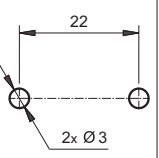
Socket	Outline Dimensions	Wiring Diagram	PCB Layout	Components Available
 <p>18FZ-2Z-C2</p> <p>Screw Terminal, DIN rail or Screw mounting, With finger protection device</p>	 <p>30, 35.4, 3.4, 2x4.2x5, 6, 8xM3, 73.5, 69.2, 22.4</p> <p>(Top View)</p>	 <p>(Top View)</p>	 <p>2xØ4.5, 59, 15</p>	<p>metallic retainer 18FZ-H1 18FF-H2 (be used in sets)</p>
 <p>18FZ-4Z-C2</p> <p>Screw Terminal, DIN rail or Screw mounting, With finger protection device</p>	 <p>30, 35.4, 3.4, 2x4.2x5, 6, 14xM3, 72.9, 69.2, 29</p> <p>(Top View)</p>	 <p>(Top View)</p>	 <p>2xØ4.5, 59, 22</p>	<p>metallic retainer 18FZ-H1 18FF-H2 (be used in sets)</p>
 <p>18FF-2Z-A2</p> <p>PCB Terminal, PCB mounting Applicable for 2 poles</p>	 <p>21.5, 13.2, 28.9, 0.3, 24.8, 15.7, 1, 2, 4, 6.4, 4.1, 6.3</p> <p>(Top View)</p>		 <p>8x Ø1.3, 13.2, 6.4, 4.1, 6.3, 4.1</p>	<p>metallic retainer 18FF-H1</p>
 <p>18FF-2Z-C1</p> <p>Screw Terminal, DIN rail or Screw mounting, Without finger protection device Applicable for 2 poles</p>	 <p>6, 3.4, 35.4, 16.5, 30, 2x4.2x5, 6, 71, 4</p> <p>(Top View)</p>	 <p>(Top View)</p>	 <p>2xØ4.5, 59, 15</p>	<p>metallic retainer 18FZ-H1 18FF-H2 (be used in sets)</p>
 <p>18FF-2Z-C2</p> <p>Screw Terminal, DIN rail or Screw mounting, With finger protection device Applicable for 2 poles</p>	 <p>6, 3.4, 35.4, 16.5, 30.6, 2x4.2x5, 6, 71, 4</p> <p>(Top View)</p>	 <p>(Top View)</p>	 <p>2xØ4.5, 59, 15</p>	<p>metallic retainer 18FZ-H1 18FF-H2 (be used in sets)</p>

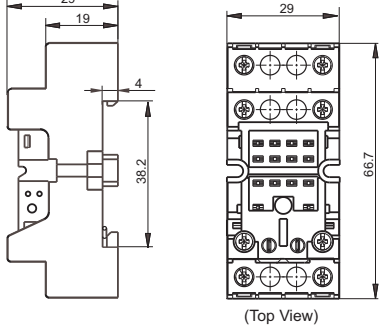
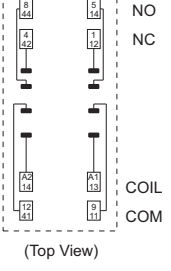
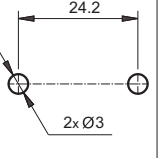

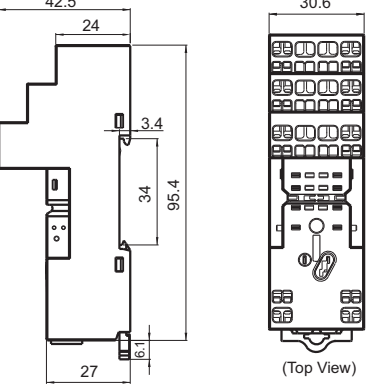
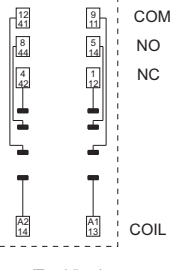



OUTLINE DIMENSIONS, WIRING DIAGRAM AND PC BOARD LAYOUT

Unit: mm

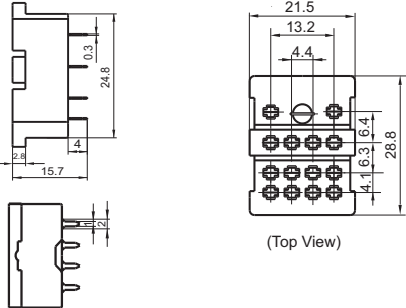
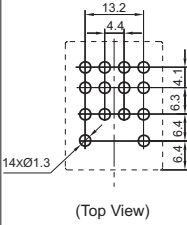
Socket	Outline Dimensions	Wiring Diagram	PCB Layout	Components Available
<p>18FF-2Z-C4</p>  <p>Screw Terminal, DIN rail or Screw mounting, With finger protection device Applicable for 2 poles</p>	 <p>(Top View)</p>	 <p>(Top View)</p>		<p>plastic retainer 18FF-H4 metallic retainer 18FF-H5 marker 18FF-M1 plug-in module HFAA to HFHU*</p>
<p>18FF-2Z-C5</p>  <p>Screw Terminal, DIN rail or Screw mounting, With finger protection device Applicable for 2 poles</p>	 <p>(Top View)</p>	 <p>(Top View)</p>		<p>plastic retainer 18FF-H4 metallic retainer 18FF-H5 marker 18FF-M1 plug-in module HFAA to HFHU*</p>
<p>18FF-2Z-C8</p>  <p>Screw Terminal, DIN rail or Screw mounting, With finger protection device Applicable for 2 poles</p>	 <p>(Top View)</p>	 <p>(Top View)</p>		<p>plastic retainer 18FF-H4 metallic retainer 18FF-H5 marker 18FF-M3 plug-in module HFAA to HFHU</p>
<p>18FF-2Z-C9</p>  <p>Spring-loaded terminal DIN rail mounting With finger protection device Applicable for 2 poles</p>	 <p>(Top View)</p>	 <p>(Top View)</p>		<p>plastic retainer 18FF-H4 metallic retainer 18FF-H5 plug-in module HFAA ~ HFHU* marker 18FF-M3</p>

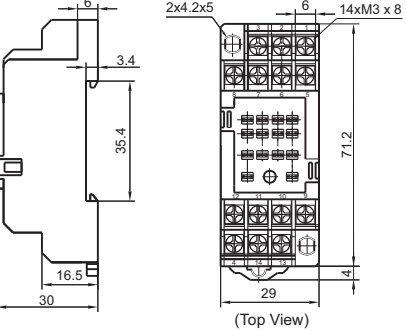
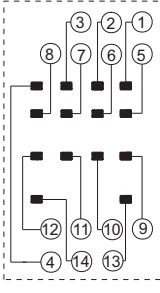
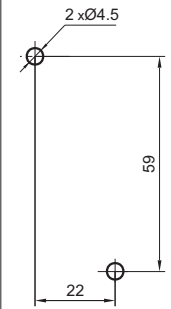

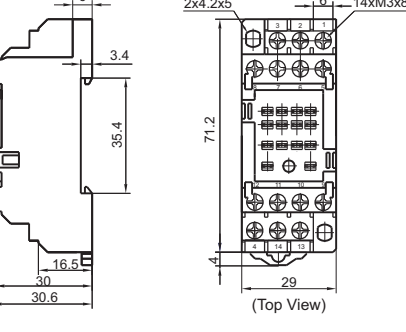
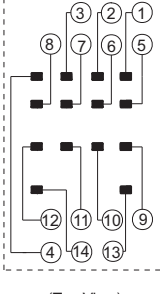
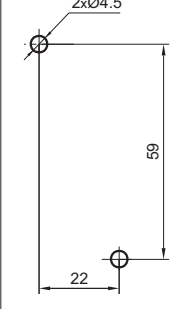

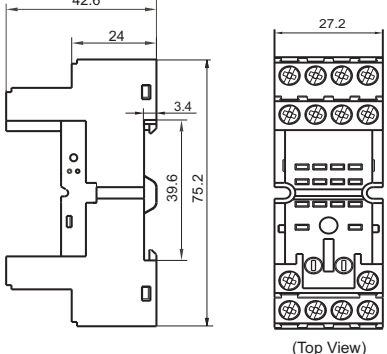
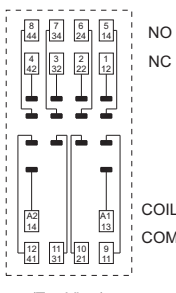
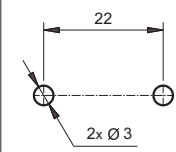

OUTLINE DIMENSIONS, WIRING DIAGRAM AND PC BOARD LAYOUT

Unit: mm

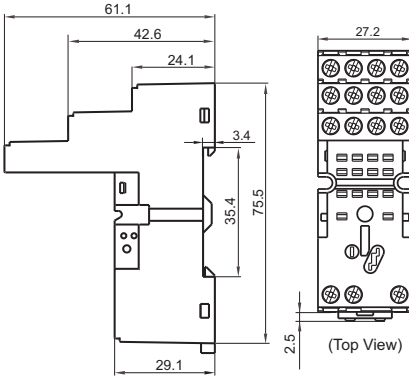
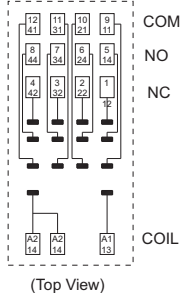
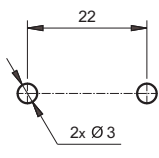
Socket	Outline Dimensions	Wiring Diagram	PCB Layout	Components Available
<p>18FF-4Z-A2</p>  <p>PCB Terminal, PCB mounting Applicable for 4 poles</p>	 <p>(Top View)</p>		 <p>(Top View)</p>	<p>metallic retainer 18FF-H1</p>
<p>18FF-4Z-C1</p>  <p>Screw Terminal, DIN rail or Screw mounting, Without finger protection device Applicable for 4 poles</p>	 <p>(Top View)</p>	 <p>(Top View)</p>		<p>metallic retainer 18FZ-H1 18FF-H2 (be used in sets)</p>
<p>18FF-4Z-C2</p>  <p>Screw Terminal, DIN rail or Screw mounting, With finger protection device Applicable for 4 poles</p>	 <p>(Top View)</p>	 <p>(Top View)</p>		<p>metallic retainer 18FZ-H1 18FF-H2 (be used in sets)</p>
<p>18FF-4Z-C4</p>  <p>Screw Terminal, DIN rail or Screw mounting, With finger protection device Applicable for 4 poles</p>	 <p>(Top View)</p>	 <p>(Top View)</p>		<p>plastic retainer 18FF-H4 metallic retainer 18FF-H5 marker 18FF-M1 plug-in module HFAA to HFHU*</p>

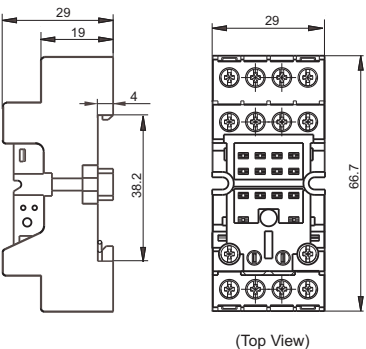
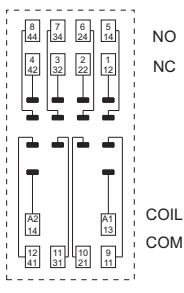
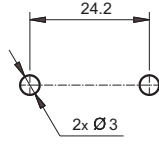
OUTLINE DIMENSIONS, WIRING DIAGRAM AND PC BOARD LAYOUT

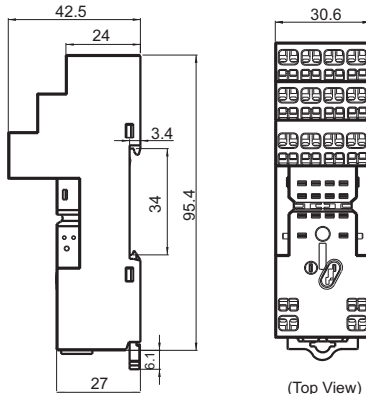
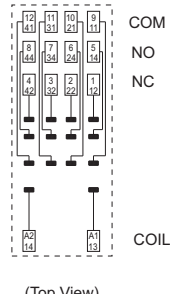
Unit: mm

Socket	Outline Dimensions	Wiring Diagram	PCB Layout	Components Available
<p>18FF-4Z-C5</p>  <p>Screw Terminal, DIN rail or Screw mounting, With finger protection device Applicable for 4 poles</p>	 <p style="text-align: center;">(Top View)</p>	 <p style="text-align: center;">(Top View)</p>		<p>plastic retainer 18FF-H4</p> <p>metallic retainer 18FF-H5</p> <p>marker 18FF-M1</p> <p>plug-in module HFAA to HFHU*</p>
<p>18FF-4Z-C8</p>  <p>Screw Terminal, DIN rail or Screw mounting, With finger protection device Applicable for 4 poles</p>	 <p style="text-align: center;">(Top View)</p>	 <p style="text-align: center;">(Top View)</p>		<p>*plastic retainer 18FF-H4</p> <p>*metallic retainer 18FF-H5</p> <p>marker 18FF-M3</p> <p>*plug-in module HFAA to HFHU</p>
<p>18FF-4Z-C9</p>  <p>Spring-loaded terminal DIN rail mounting With finger protection device Applicable for 2 poles</p>	 <p style="text-align: center;">(Top View)</p>	 <p style="text-align: center;">(Top View)</p>		<p>plastic retainer 18FF-H4</p> <p>metallic retainer 18FF-H5</p> <p>plug-in module HFAA ~ HFHU*</p> <p>marker 18FF-M3</p>

DIMENSION OF RELATED COMPONENT (AVAILABLE)

Unit: mm

Retainer

18FZ-H1 (Metallic retainer)

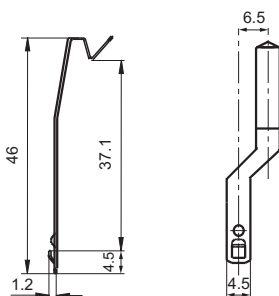

18FF-H1 (Metallic retainer)

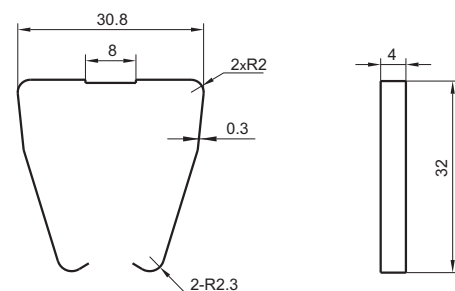

Remark: This retainer is for specific series. Please be aware before ordering.

DIMENSION OF RELATED COMPONENT (AVAILABLE)

Unit: mm

18FF-H2 (Metallic retainer)

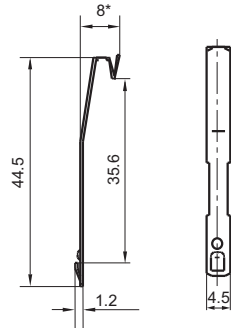

18FF-H4 (Plastic retainer)

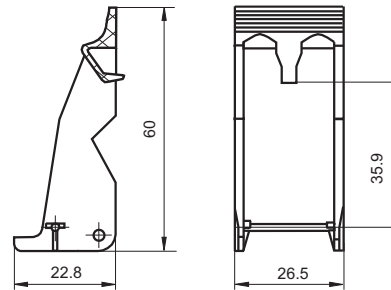

Remark: This retainer is for specific series. Please be aware before ordering.

18FF-H5 (Metallic retainer)

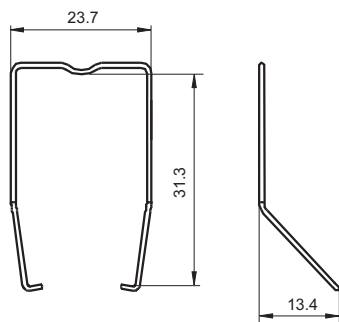

Marker

18FF-M1

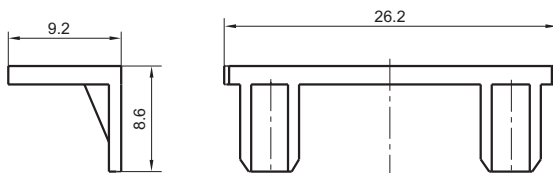

18FF-M3

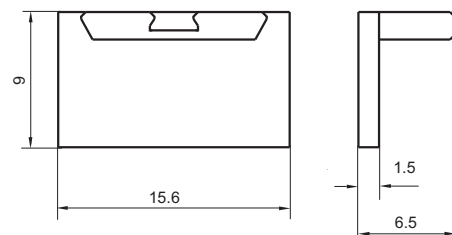

SELECTION OF PARTS

Type of Relay	Mounting termination	Socket	Retainer	Marker	Module
HF18FZ/□□-2Z□□□1/2□	without button	18FF-2Z-A2	18FF-H1	-	-
		18FF-2Z-C1	18FF-H2		
		18FF-2Z-C2			
		18FZ-2Z-C2			
		18FF-2Z-C4	18FF-H4/H5	18FF-M1	HFAA~HFHU
		18FF-2Z-C5			
		18FF-2Z-C8		18FF-M3	
		18FF-2Z-C9			
HF18FZ/□□-4Z□□□1/2□	without button	18FF-4Z-A2	18FF-H1	-	-
		18FF-4Z-C1	18FF-H2		
		18FF-4Z-C2			
		18FZ-4Z-C2			
		18FF-4Z-C4	18FF-H4/H5	18FF-M1	HFAA~HFHU
		18FF-4Z-C5			
		18FF-4Z-C8		18FF-M3	
		18FF-4Z-C9			
HF18FZ/□□-2Z□□□3□	with button	18FF-2Z-C1	18FZ-H1	-	-
		18FF-2Z-C2			
		18FZ-2Z-C2			
		18FF-2Z-C4	18FF-H4	18FF-M1	HFAA~HFHU
		18FF-2Z-C5			
		18FF-2Z-C8		18FF-M3	
		18FF-2Z-C9			
HF18FZ/□□-4Z□□□3□	with button	18FF-4Z-C1	18FZ-H1	-	-
		18FF-4Z-C2			
		18FZ-4Z-C2			
		18FF-4Z-C4	18FF-H4	18FF-M1	HFAA~HFHU
		18FF-4Z-C5			
		18FF-4Z-C8		18FF-M3	
		18FF-4Z-C9			

Things to be noticed when selecting sockets:

1. Please choose suitable relay socket according to the actual mounting environment, relay contact poles and terminal layout. If there is any query on selection, please contact Hongfa for the technical service.
2. Socket which can be mounted with markers is furnished with a marker; as for other related components, they should be selected separately. Please do give clear indication of the types of relay sockets and related components you choose while placing order.
3. The above is only an example of typical socket and related component type which is suitable to HF18FZ relay. If you have any special requirements, please contact us.
4. Main outline dimension, outline dimension > 50mm, tolerance should be $\pm 1\text{mm}$; 20mm < outline dimension $\leq 50\text{mm}$, tolerance should be $\pm 0.5\text{mm}$; 5mm < outline dimension $\leq 20\text{mm}$, tolerance should be $\pm 0.4\text{mm}$; outline dimension $\leq 5\text{mm}$, tolerance should be $\pm 0.3\text{mm}$.
5. DIN rail mounting: recommend to use standard rail 35×7.5×1mm, 35×15×1mm.

Disclaimer

The specification is for reference only. See to "Terminology and Guidelines" for more information. Specifications subject to change without notice. We could not evaluate all the performance and all the parameters for every possible application. Thus the user should be in a right position to choose the suitable product for their own application. If there is any query, please contact Hongfa for the technical service. However, it is the user's responsibility to determine which product should be used only.

© Xiamen Hongfa Electroacoustic Co., Ltd. All rights of Hongfa are reserved.