

HF25F

SUBMINIATURE HIGH POWER RELAY



File No.:E134517



File No.:40026917



File No.:R50207576



File No.:CQC09002028692



Features

- Small and for microwave oven
- 20A switching capability
- 1.5HP 250VAC approved by UL standard
- 5kV impulse withstand voltage (between coil and contacts)
- PCB & QC layouts
- Flux proofed types available

CONTACT DATA

Contact arrangement	1A
Contact resistance ¹⁾	100mΩ max.(at 1A 6VDC)
Contact material	AgSnO ₂
Contact rating	Resistive: 20A 250VAC 1.5HP 250VAC
Max. switching voltage	250VAC / 30VDC
Max. switching current	20A
Max. switching power	5000VA / 480W
Mechanical endurance	2 x 10 ⁶ ops
Electrical endurance	1 x 10 ⁵ ops (20A 250VAC, Resistive load, Room temp., 1s on 1s off)

Notes: 1) The data shown above are initial values.

CHARACTERISTICS

Insulation resistance	1000MΩ (at 500VDC)	
Dielectric strength	Between coil & contacts	5000VAC 1min
	Between open contacts	1000VAC 1min
Operate time (at rated. volt.)	15ms max.	
Release time (at rated. volt.)	5ms max.	
Humidity	5% to 85% RH	
Shock resistance	Functional	98m/s ²
	Destructive	980m/s ²
Ambient temperature	-40°C to 85°C	
Vibration resistance	10Hz to 55Hz 1.5mm DA	
Termination	PCB & QC	
Unit weight	Approx. 16.5g	
Construction	Flux proofed	

Notes: 1) The data shown above are initial values.

2) Please find coil temperature curve in the characteristic curves below.

3) UL insulation system: Class F

COIL

Coil power	Approx. 500mW
------------	---------------

COIL DATA

at 23°C

Nominal Voltage VDC	Pick-up Voltage VDC max. ²⁾	Drop-out Voltage VDC min. ²⁾	Max. Voltage VDC ³⁾	Coil Resistance Ω
5	3.75	0.25	6.50	50 x (1±10%)
6	4.50	0.30	7.80	72 x (1±10%)
9	6.75	0.45	11.7	162 x (1±10%)
12	9.00	0.60	15.6	288 x (1±10%)
18	13.5	0.90	23.4	648 x (1±10%)
24	18.0	1.20	31.2	1152 x (1±10%)

Notes: 1) The data shown above are initial values.

2) When requiring pick-up voltage <75% of nominal voltage, special order allowed.

3) *Maximum voltage refers to the maximum voltage which relay coil could endure in a short period of time.

SAFETY APPROVAL RATINGS

UL/CUL	20A 250VAC 16A 30VDC 1.5HP 250VAC
VDE	20A 250VAC 16A 30VDC
TÜV	20A 250VAC 16A 30VDC

Notes: 1) All values unspecified are at room temperature.

2) Only typical loads are listed above. Other load specifications can be available upon request.



HONGFA RELAY

ISO9001, ISO/TS16949, ISO14001, OHSAS18001, IECQ QC 080000 CERTIFIED

2020 Rev. 1.01

ORDERING INFORMATION

Type	HF25F /	012	-H	1	(XXX)
Coil voltage	5, 6, 9, 12, 18, 24VDC				
Contact arrangement	H: 1 Form A				
Version	1: 1 type 2: 2 type 3: 3 type 4: 4 type Nil: Standard type				
Special code ²⁾	XXX: Customer special requirement		Nil: Standard		

Notes: 1) Contact is recommended for suitable condition and specifications if water cleaning or surface process is involved in assembling relays on PCB.

2) The customer special requirement express as special code after evaluating by Hongfa.

OUTLINE DIMENSIONS, WIRING DIAGRAM AND PC BOARD LAYOUT

Unit: mm

Standard:

Outline Dimensions

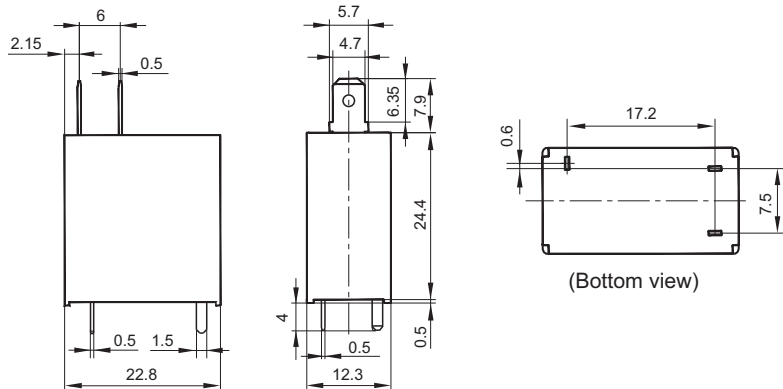

PCB Layout (Bottom view)

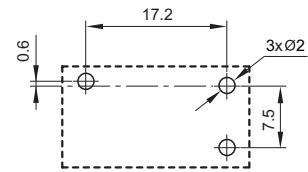

Wiring Diagram

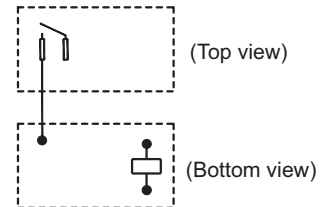

1 type:

Outline Dimensions

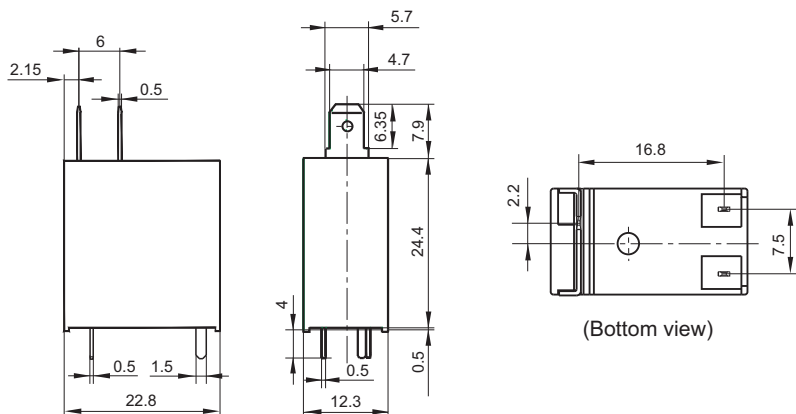

PCB Layout (Bottom view)

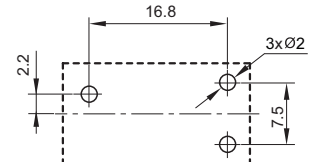

Wiring Diagram

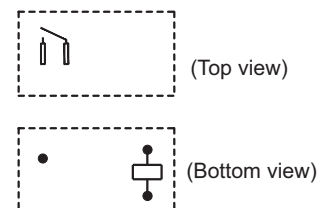

2 type:

Outline Dimensions

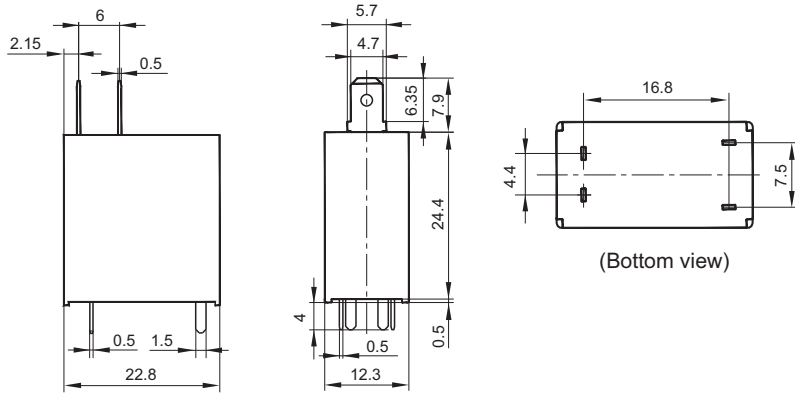

PCB Layout (Bottom view)

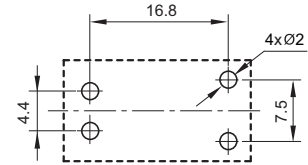

Wiring Diagram



(Top view)



(Bottom view)

3 type:

Outline Dimensions

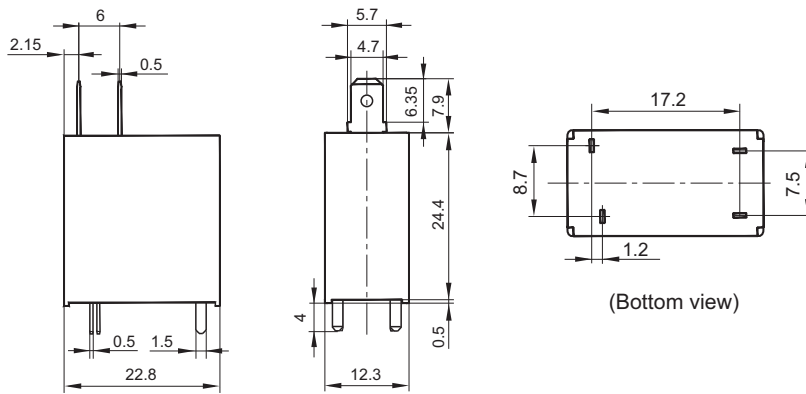

PCB Layout (Bottom view)

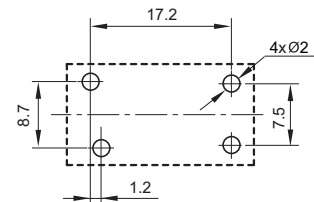

Wiring Diagram



(Top view)

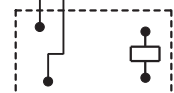

(Bottom view)

OUTLINE DIMENSIONS, WIRING DIAGRAM AND PC BOARD LAYOUT

Unit: mm

4 type:

Outline Dimensions

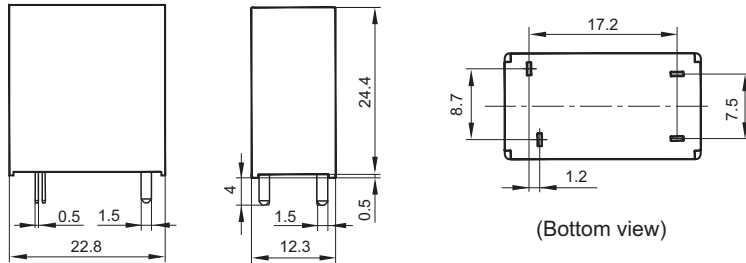

PCB Layout (Bottom view)

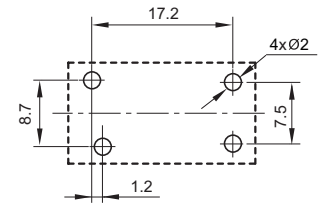

Wiring Diagram

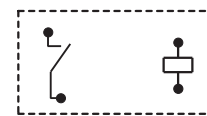

(Bottom view)

- Remark: 1) In case of no tolerance shown in outline dimension: outline dimension $\leq 1\text{mm}$, tolerance should be $\pm 0.2\text{mm}$; outline dimension $\leq 5\text{mm}$, tolerance should be $\pm 0.3\text{mm}$; outline dimension $> 5\text{mm}$, tolerance should be $\pm 0.4\text{mm}$.
 2) The tolerance without indicating for PCB layout is always $\pm 0.1\text{mm}$.

CHARACTERISTIC CURVES

MAXIMUM SWITCHING POWER

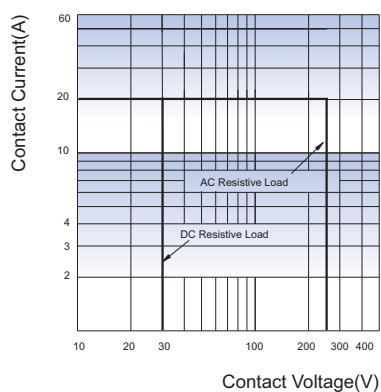

COIL TEMPERATURE RISE

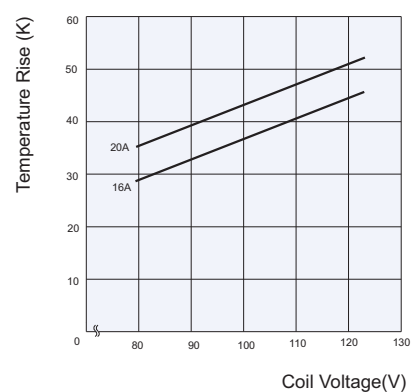

Disclaimer

The specification is for reference only. See to "Terminology and Guidelines" for more information. Specifications subject to change without notice. We could not evaluate all the performance and all the parameters for every possible application. Thus the user should be in a right position to choose the suitable product for their own application. If there is any query, please contact Hongfa for the technical service. However, it is the user's responsibility to determine which product should be used only.

© Xiamen Hongfa Electroacoustic Co., Ltd. All rights of Hongfa are reserved.