

# HF3605

# WINDOW CONTROLLER



### Typical Applications

Automotive Window Control

### Features

- Use MCU control circuit to ensure stable performance
- With Manual & automatic down function
- With overload protection
- Connect with DJ7081-2.3-20 easy to mount

## CHARACTERISTICS

Nominal voltage	12VDC
Operating voltage range	9VDC to 16VDC
Contact rating	10A 12VDC (Simulated motor load)
Electrical endurance	5×10 <sup>4</sup> OPS (Simulated motor load 10A with Un-reversed and Reversed operation, and operating on 10.2s on 9.8s off respectively)
Ambient temperature	-40°C to 85°C
Weight	Approx. 70g

## OUTLINE DIMENSIONS AND WIRING DIAGRAM

Unit: mm

### Outline Dimensions

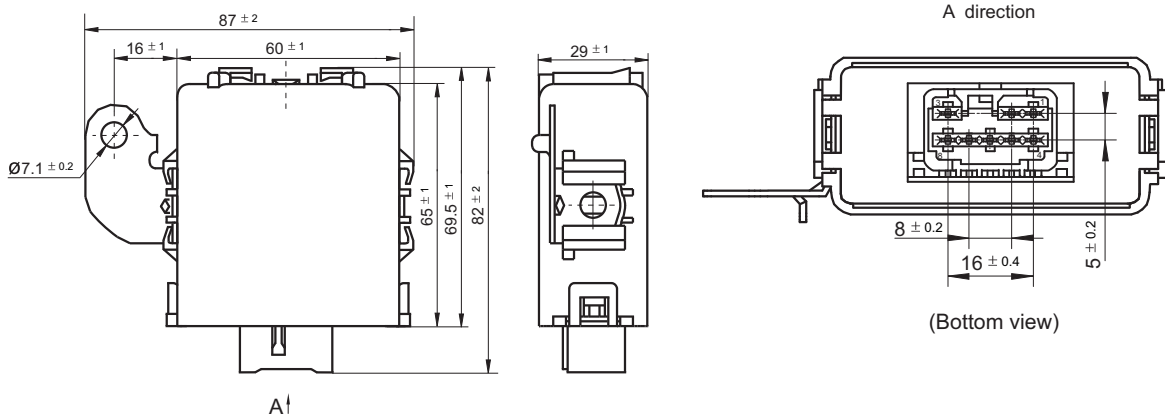

HONGFA RELAY

ISO9001, ISO/TS16949, ISO14001, OHSAS18001, IECQ QC 080000 CERTIFIED

2015 Rev. 1.00

Outline Dimensions

Wiring Diagram

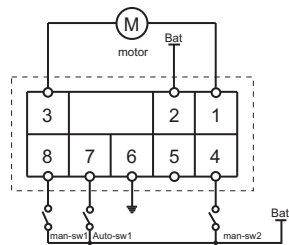

- 1) As left shown HF3605, 1 and 3 - motor, 2 - Battery+, 6 - GND, 4 and 8 - Manal switch inputs, 7 - Auto-switch input.
- 2) Output 1 is positive and 3 is negative when 4 active.
- 3) Output 3 is positive and 1 is negative when 7 or 8 active.

Disclaimer

The specification is for reference only. See to "Terminology and Guidelines" for more information. Specifications subject to change without notice. In case there is specific criterion (such as mission profile, technical specification, PPAP etc.) checked and agreed by and between customer and Hongfa, this specific criterion should be taken as standard regarding any requirement on Hongfa product.

We could not evaluate all the performance and all the parameters for every possible application. Thus the user should be in a right position to choose the suitable product for their own application. If there is any query, please contact Hongfa for the technical service. However, it is the user's responsibility to determine which product should be used only.

© Xiamen Hongfa Electroacoustic Co., Ltd. All rights of Hongfa are reserved.