

HFA6

SAFETY RELAY (RELAY WITH FORCIBLY GUIDED CONTACTS)

C **RU** **US**
File No.:E134517

TÜV
File No.:B120553286004



Features

- Multi contact arrangements: 5NO+1NC, 4NO+2NC, 3NO+3NC
- Forcibly guided contacts according to EN50205
- 6A switching capability
- Low input power: 500mW
- High insulation capability: 10kV surge voltage between input and output
- UL insulation system: Class F available

CONTACT DATA

Contact arrangement	5NO+1NC (5H1D type) 4NO+2NC (4H2D type) 3NO+3NC (3H3D type)
Forcibly guided contacts Type (according to EN50205)	Type A
Contact resistance ¹⁾	100mΩ (at 1A 6VDC)
Contact material	AgSnO ₂
Contact rating (Res. load)	6A 250VAC / 30VDC
Max. switching voltage	400VAC / 30VDC
Max. switching current	6A
Max. switching power	1500VA / 180W
Mechanical endurance	1 x 10 ⁷ ops
Electrical endurance	1 x 10 ⁵ ops (1NO: 6A 30VDC, Resistive load, Room temp., 1s on 9s off) 1 x 10 ⁵ ops (1NO: 6A 250VAC, Resistive load, Room temp., 1s on 9s off)

Notes: 1) The data shown above are initial values.

COIL

Coil power	Approx. 500mW
------------	---------------

COIL DATA at 23°C

Nominal Voltage VDC	Pick-up Voltage VDC max. ¹⁾	Drop-out Voltage VDC min. ¹⁾	Max. Voltage VDC ²⁾	Coil resistance Ω
6	4.5	0.6	6.6	72 x (1±10%)
9	6.8	0.9	9.9	162 x (1±10%)
12	9.0	1.2	13.2	288 x (1±10%)
18	13.5	1.8	21.78	648 x (1±10%)
24	18.0	2.4	26.4	1152 x (1±10%)
36	27.0	3.6	39.6	2592 x (1±10%)
48 ³⁾	36.0	4.8	52.8	4608 x (1±10%)

- Notes: 1) The data shown above are initial values.
2) Maximum voltage refers to the maximum voltage which relay coil could endure in a short period of time.
3) For products with rated voltage ≥ 48V, measures should be taken to prevent coil overvoltage in order to protect coil in test and application (eg. Connect diodes in parallel).

CHARACTERISTICS

Insulation resistance	1000MΩ (at 500VDC)	
Dielectric strength	Between coil & contacts	4000VAC 1 min
	Between open contacts	1500VAC 1 min
	Between contact sets	2500VAC 1 min (11-12/13-14) 4000VAC 1 min (Other)
Surge voltage	Between coil & contacts	10kV (1.2 / 50μs)
	Between contact sets	5kV (1.2 / 50μs)
Operate time (at rated voltage)	20ms max.	
Release time (at rated voltage)	20ms max.	
Temperature rise (at rated voltage)	≤70K (Coil driving voltage: 1.1 times Un, Contact current-carrying: rated current, at 85°C)	
Vibration resistance	NO/NC:10Hz to 55Hz 1.5mm DA NO:55Hz to 200Hz, 98m/s ² NC:55Hz to 200Hz, 49m/s ²	
Shock resistance	Functional	100m/s ²
	Destructive	980m/s ²
Creepage distance	Between coil & contacts	8mm
	Between contacts	5.5mm
Clearance distance	Between coil & contacts	8mm
	Between contacts	5.5mm
Humidity	5% to 85% RH	
Ambient temperature	-40°C to 85°C	
Termination	PCB	
Unit weight	Approx. 23g	
Construction	Flux proofed	

- Notes: 1) The data shown above are initial values.
2) UL insulation system: Class F, Class B.

SAFETY APPROVAL RATINGS

UL/CUL	6A 277VAC / 250VAC / 125VAC at 85°C 6A 30VDC at 85°C Pilot duty: 1.5A 240VAC 3A 120VAC
TÜV	6A 277VAC / 30VDC 1.5A / 2A 240VAC(AC-15)

- Notes: 1) All values unspecified are at room temperature.
2) Only typical loads are listed above. Other load specifications can be available upon request.



HONGFA RELAY
ISO9001, ISO/TS16949, ISO14001, OHSAS18001, IECQ QC 080000 CERTIFIED

2019 Rev. 1.00

ORDERING INFORMATION

Type	HFA6 / 24	-5H1D	T	G	F	(XXX)
Coil voltage	6, 9, 12, 18, 24, 36, 48VDC					
Contact arrangement	5H1D: 5NO+1NC 3H3D: 3NO+3NC		4H2D: 4NO+2NC			
Contact material	T: AgSnO ₂					
Contact plating	G: Gold plated					
Insulation class	F: Class F		Nil: Class B			
Special code ⁴⁾	XXX: Customer special requirement		Nil: Standard			

- Notes:**
- 1) Flux-proofed relays can not be used in the environment with pollutants like H₂S, SO₂, NO₂, dust, etc.
 - 2) Contact is recommended for suitable condition and specifications if water cleaning or surface process is involved in assembling relays on PCB.
 - 3) For gold plated type, the min. switching current and min. switching voltage is 10mA 5VDC.
 - 4) The customer special requirement express as special code after evaluating by Hongfa.

OUTLINE DIMENSIONS, WIRING DIAGRAM AND PC BOARD LAYOUT

Unit: mm

HFA6/□□-5H1DT□(□□□)

Outline Dimensions

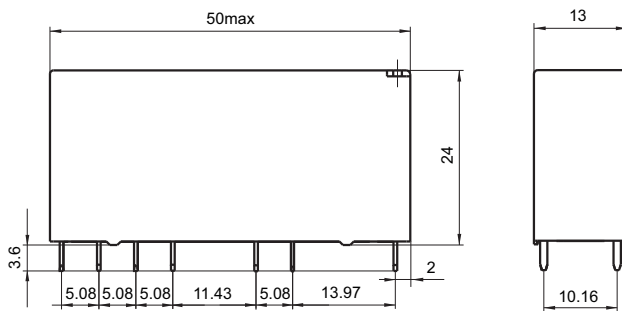

P↑

P direction

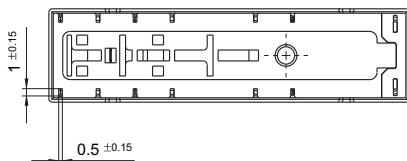

Wiring Diagram

(Bottom view)

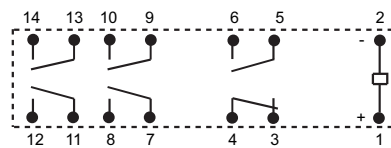

PCB Layout

(Bottom view)

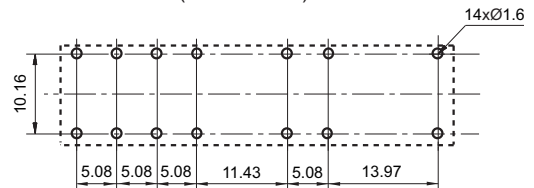

OUTLINE DIMENSIONS, WIRING DIAGRAM AND PC BOARD LAYOUT

Unit: mm

HFA6/□□-4H2DT□(□□□)

Outline Dimensions

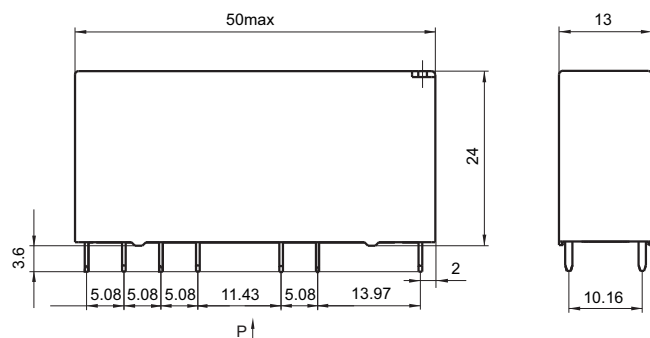

Wiring Diagram

(Bottom view)

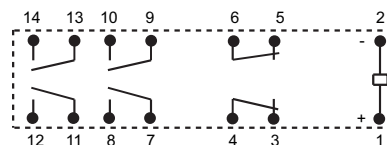

PCB Layout

(Bottom view)

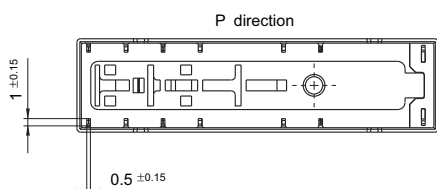
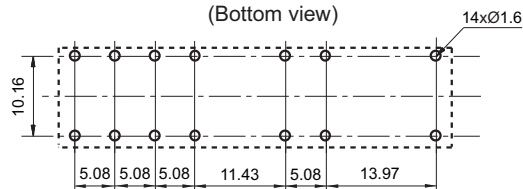

HFA6/□□-3H3DT□(□□□)

Outline Dimensions

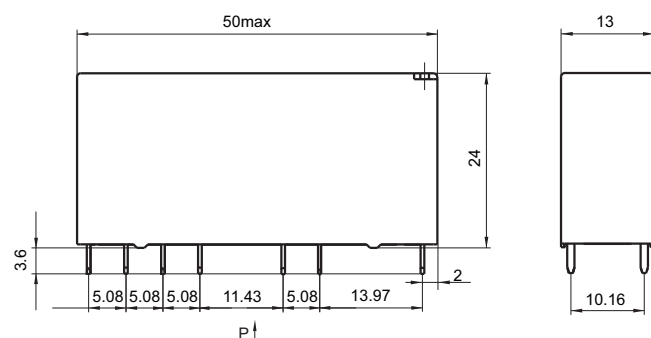

Wiring Diagram

(Bottom view)

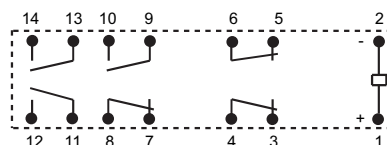

PCB Layout

(Bottom view)

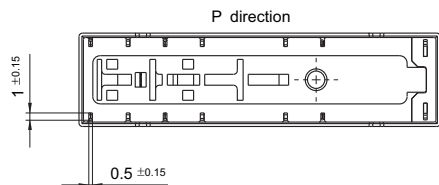
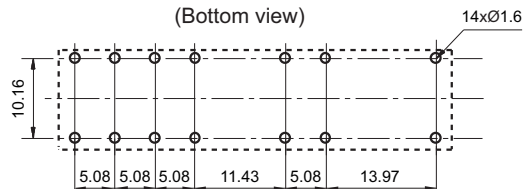

- Remark: 1) In case of no tolerance shown in outline dimension: outline dimension $\leq 1\text{mm}$, tolerance should be $\pm 0.2\text{mm}$; outline dimension $> 1\text{mm}$ and $\leq 5\text{mm}$, tolerance should be $\pm 0.3\text{mm}$; outline dimension $> 5\text{mm}$, tolerance should be $\pm 0.4\text{mm}$.
 2) The tolerance without indicating for PCB layout is always $\pm 0.1\text{mm}$.

CHARACTERISTIC CURVES

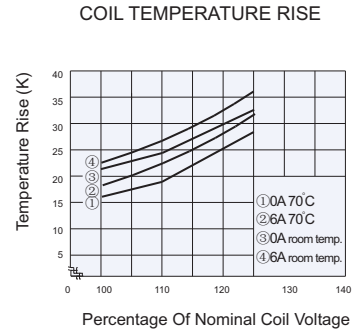
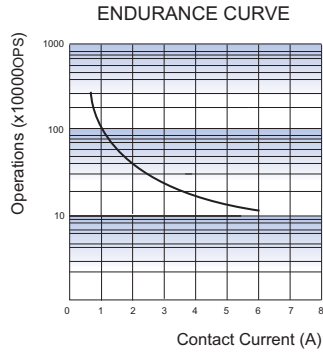
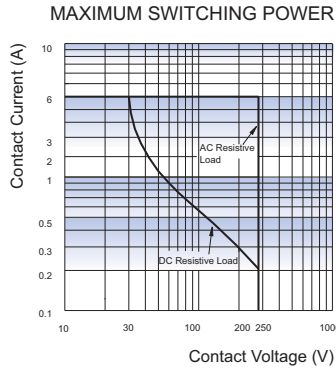

Test conditions:
1NO, Resistive load, 250VAC,
Room temp., 1s on 9s off

Relay Sockets

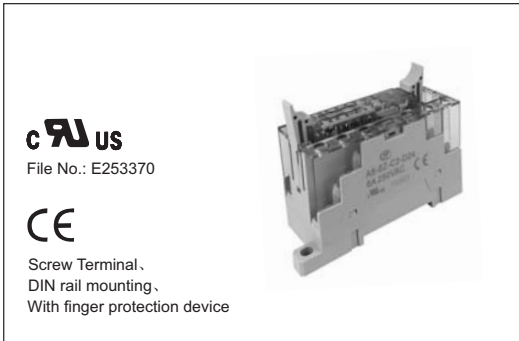

Features

- The dielectric strength (between coil and contacts) can reach 2500VAC and the insulation resistance is 1000 MΩ
- DIN rail or Screw mounting
- With diode to protect the coil and to eliminate the converse current
- With finger protection device
- Built-in retainer and extractor

CHARACTERISTICS

Unit: mm

Type	Nominal Voltage	Nominal Current	Applicable coil voltage of relay	Ambient Temperature	Torque*	Max.wire cross section mm ²	Wire Strip Length	Unit weight	Notes
A6-6Z-C2-D24	250VAC	6A	(6 to 24)VDC	-25 °C to 55 °C	1.0N · m	2 x 1.5	7mm	-	With LED
A6-6Z-C2-D60	250VAC	6A	(36 to 60)VDC	-25 °C to 55 °C	1.0N · m	2 x 1.5	7mm	-	With LED
A6-6Z-C2-D110	250VAC	6A	(85 to 110)VDC	-25 °C to 55 °C	1.0N · m	2 x 1.5	7mm	-	With LED
A6-6Z-C2	250VAC	6A	(6 to 110)VDC	-25 °C to 55 °C	1.0N · m	2 x 1.5	7mm	Approx. 63g	Without LED

Notes: * Refers to wire-assembled torque.

OUTLINE DIMENSIONS, WIRING DIAGRAM AND PC BOARD LAYOUT

Unit: mm

Socket	Outline Dimensions	Wiring Diagram	Components Available
A6-6Z-C2-X	<p>(Bottom view)</p>	<p>(Bottom view)</p>	<p>With LED</p> <p>Without LED</p>

Disclaimer

The specification is for reference only. See to "Terminology and Guidelines" for more information. Specifications subject to change without notice. We could not evaluate all the performance and all the parameters for every possible application. Thus the user should be in a right position to choose the suitable product for their own application. If there is any query, please contact Hongfa for the technical service. However, it is the user's responsibility to determine which product should be used only.

© Xiamen Hongfa Electroacoustic Co., Ltd. All rights of Hongfa are reserved.