

HFE82V-120

DIRECT CURRENT RELAY



Features

- Ceramic brazing sealed technology guarantees no risk of arc leaking and ensures no fire or explosion.
- Filled with gas (mostly hydrogen) to effectively prevent the oxidation burnt; the contact resistance is low and stable, and the contact part can meet IP67 protection level.
- Carrying current 120A continuously at 85°C.
- Meet the requirement of abnormal working condition, and can switch 10 times of over-current.
- Insulation resistance is 1000MΩ(1000VDC), and dielectric strength between the coil and contacts is 4kV, which meets the requirements of IEC 60664-1.

CONTACT DATA

Contact arrangement	1H
Contact resistance	≤0.5mΩ(at 20A)
Rated load current	120A
Mechanical endurance	3 x 10 ⁵ ops
Max. switching voltage	750VDC
Max. breaking current	1200A (450VDC) 1ops

		450V Type	750V Type
Max. switching power		54kW	90kW
Electrical endurance ¹⁾	Cap. load	Making: 2.5 x 10 ⁴ ops (22.5VDC, τ =1ms, Inrush 400A, Steady 120A)	Making: 2.5 x 10 ⁴ ops (37.5VDC, τ =1ms, Inrush 400A, Steady 120A)
		Switching: 1.2 x 10 ³ ops (450VDC, 120A)	Switching: 500ops (750VDC, 120A)
	Res. load	Switching: 5 x 10 ⁴ ops (450VDC, 15A)	Breaking: 1ops (750VDC, 1200A)
		Switching: 500ops (450VDC, -120A)	
		Breaking: 1ops (450VDC, 1200A)	
Current carrying capacity ²⁾		120A: Cont.	
		150A: 2h	
		200A: 10min	
		300A: 2min	
		400A: 40s	
		900A: 6s	

Notes: 1) Until special statement, the temperature of electrical endurance is at 23°C and the on-off ratio is 0.6s:5.4s.

The coil was not connected to the surge suppression device during the test. Please note that the use of a well-connected diode will greatly increase the release time of the relay, resulting in a reduced lifetime.

2) Ambient temperature is at 85°C and cross section area of wire is 50mm² min. See Pic Endurance Capacity Curve for more information.

COIL

Nominal Voltage VDC	Pick-up Voltage VDC max.	Drop-out Voltage VDC min.	Coil power W
12	≤9	≥1	6
24	≤18	≥2	6

Notes: The values above are conservative values within the temperature range(-40°C to 85°C), the pick-up voltage and drop-out voltage are showed in the Pic Pick-up Voltage / Drop-out Voltage Curve.

CHARACTERISTICS

Insulation resistance		1000MΩ (1000VDC)
Dielectric strength	Between coil & contacts	4000VAC 1min
	Between open contacts	3000VAC 1min
Operate time (at nomi. volt.)		≤30ms
Release time (at nomi. volt.)		≤10ms
Shock resistance	Functional	196m/s ²
	Destructive	490m/s ²
Vibration resistance		10Hz ~ 500Hz 49m/s ²
Humidity		5% ~ 85% RH
Ambient temperature		-40°C ~ 85°C
Termination		M4 Screw terminal female
Unit weight		Approx.340g
Outline dimensions		75.5mm x 40.0mm x 75.0mm

Notes: The data shown above are initial values.



HONGFA RELAY

ISO9001、ISO/TS16949、ISO14001、OHSAS18001、IECQ QC 080000 CERTIFIED

2019 Rev. 1.00

ORDERING INFORMATION

Type	HFE82	V	-120 / 750-	12 -	H	C	5	(XXX)
Application	V: Vehicle							
Contact rating	120: 120A							
Load voltage	Nil: 450VDC 750: 750VDC							
Coil voltage	12: 12VDC 24: 24VDC							
Contact arrangement	H: 1 Form A							
Coil input terminal	C: Connector							
Load input terminal	5: Screw terminal female							
Special code ¹⁾	XXX: Customer special requirement		Nil: Standard					

Notes: 1) The customer special requirement express as special code after evaluating by Hongfa.

OUTLINE DIMENSIONS, INSTALLATION HOLE, COIL WIRING DIAGRAM

Unit: mm

Outline Dimensions

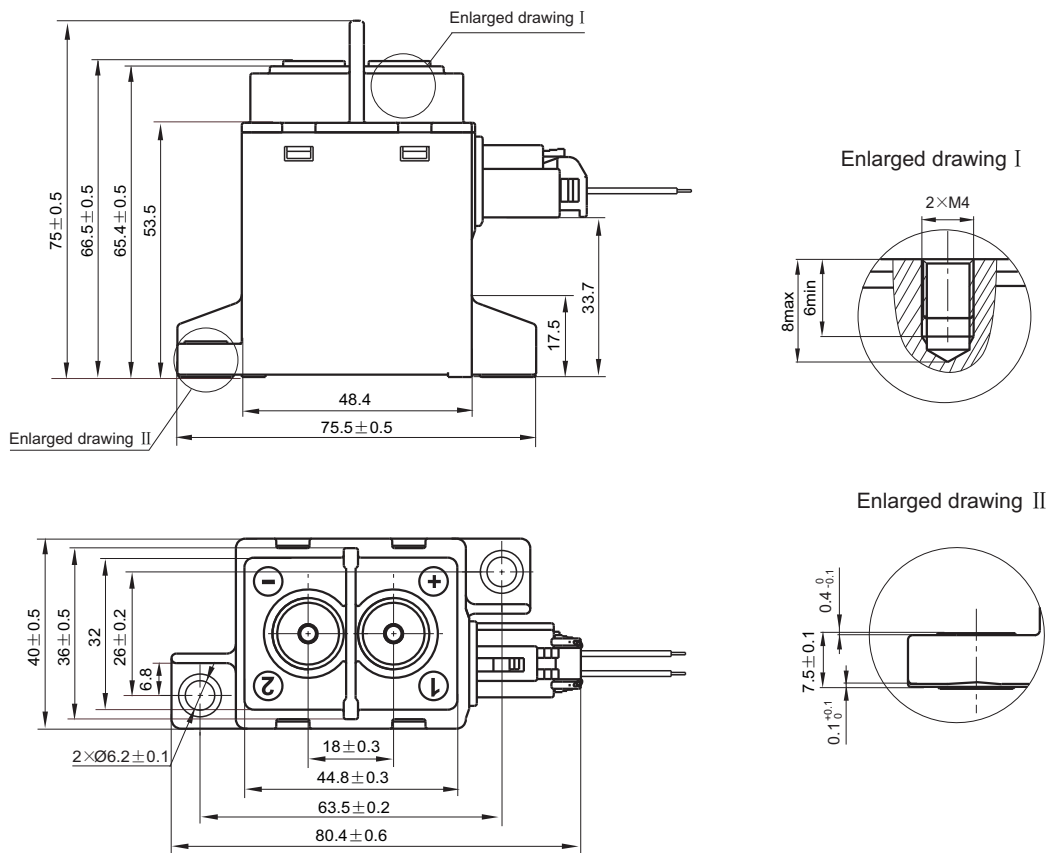

Remark: In case of no tolerance shown in outline dimension: outline dimension ≤ 10mm, tolerance should be ±0.3mm; outline dimension > 10mm and ≤ 50mm, tolerance should be ±0.5mm; outline dimension > 50mm, tolerance should be ±0.8mm.

OUTLINE DIMENSIONS, INSTALLATION HOLE, COIL WIRING DIAGRAM

Unit: mm

Combined Bolt Drawing
(Optional)

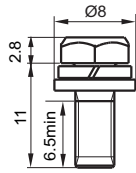

Installation Hole

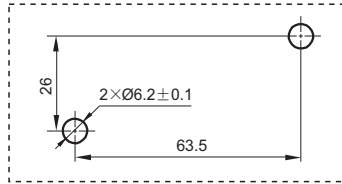

Coil Wiring Diagram

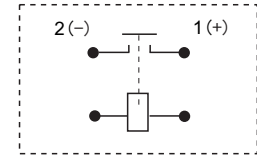

Note: Polarity option on the loads;
no polarity on coil.

Wiring Diagram

C: Connector(Tianhai: 0435308)

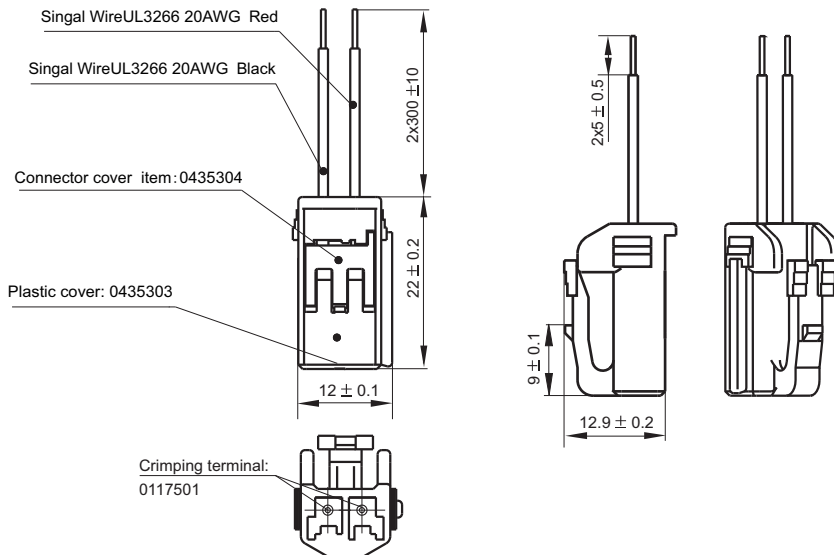

Notes: Applicable Connector: Yazaki 7283-1020(Optional, Not Included).

CHARACTERISTIC CURVES

Endurance Capacity Curve

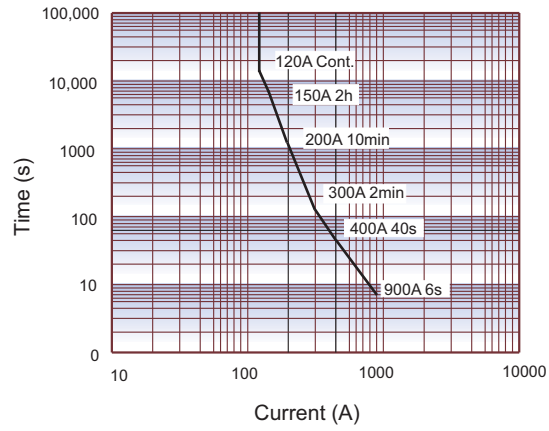

Notes: The data above is measured at the environment temperature 85°C with cross section area of wire $\geq 50\text{mm}^2$. This data is only for reference and please do not use it for fuse selection.

Pick-up Voltage / Drop-out Voltage Curve

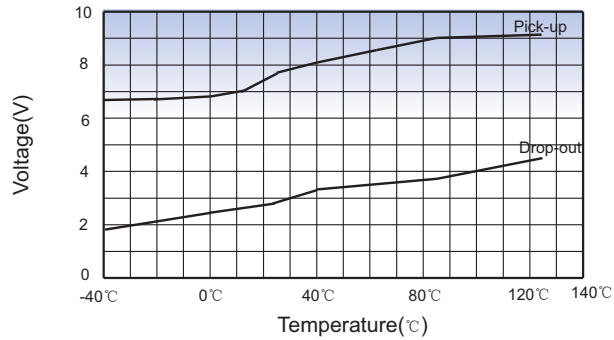

Notes: When the coil voltage is 12V, the data above is taken as sample value and only for reference (Sample quantity: n=3)

Cautions

1. In case of loosening, please use washer when install the relay with M5 screw, and the torque within 3N·m to 4N·m, the torque of fixing screw at terminals shall be within 2N·m to 3N·m. The torque beyond the range may cause damage.

Installation for terminal with load				Relay installation	
Installation way	Torque requirement	Hole diameter of copper bar	Thickness of copper bar	Installation way	Torque requirement
M4 bolt	2N·m~3N·m	Ø4~Ø4.5	3mm	M5 bolt	3N·m~4N·m

2. Please do not adhere foreign materials like oil on the terminals and please use the wire with cross section area 50mm² min, otherwise the terminal parts may have abnormal heating.

3. Cautions of Relay installation:

Unrecommended method

The hole of mounting panel at customer-side is too large.

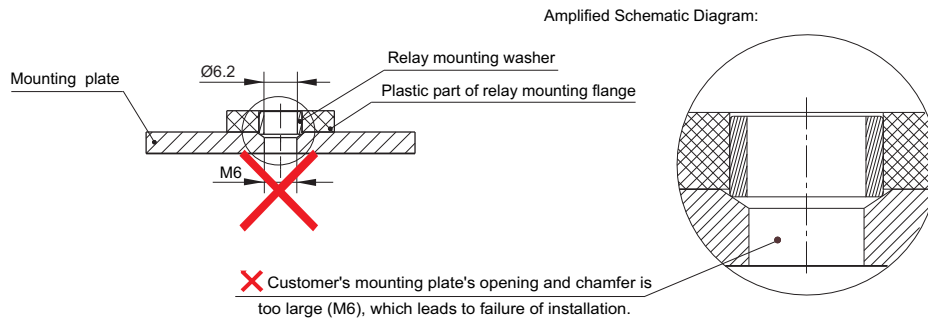

Recommended method

The hole in mounting panel at customer-side is M5

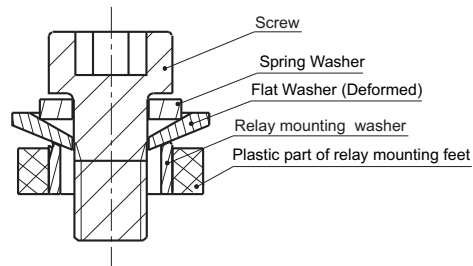
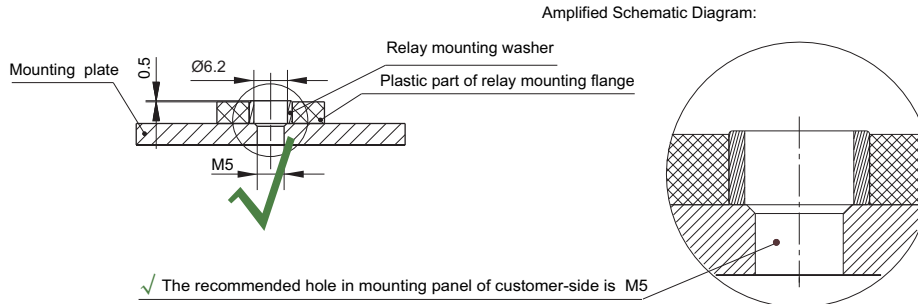

When use M5 screw, the thickness and strength of the washer needs to be guaranteed or it may deform and burst the cover.

Disclaimer

The specification is for reference only. See to "Terminology and Guidelines" for more information. Specifications subject to change without notice. We could not evaluate all the performance and all the parameters for every possible application. Thus the user should be in a right position to choose the suitable product for their own application. If there is any query, please contact Hongfa for the technical service. However, it is the user's responsibility to determine which product should be used only.