

HFKJ/HFKJ-T

AUTOMOTIVE RELAY



Typical Applications

Central door lock, Power doors and windows, Seat adjustment, Sunroof motor control, Mirror adjustment

Features

- 25A motor locked load
- Extremely small relay
- Change-over contact version
- Coil wire insulation class H (180°C)
- HFKJ-T(reflow soldering version available)
- RoHS & ELV compliant

CHARACTERISTICS

Contact arrangement	2C(H-bridge)
Voltage drop (initial) ¹⁾	Typ.: 50mV (at 10A) Max.: 250mV (at 10A)
Max. continuous current ²⁾	35A 2min 12VDC at 23°C HFKJ:25A 2min 12VDC at 85°C HFKJ-T:30A 2min 12VDC at 85°C HFKJ-T:20A 2min 12VDC at 125°C
Max. switching current ³⁾	NO:40A NC:20A
Max. switching voltage	16VDC
Min. contact load ⁴⁾	1A 6VDC
Electrical endurance	See "CONTACT DATA"
Mechanical endurance	1 x 10 ⁷ OPS (300OPS/min)
Initial insulation resistance	100MΩ (at 500VDC)
Dielectric strength ⁵⁾	between contacts: 500VAC between coil & contacts: 500VAC
Operate time	Max.: 10ms (at nomi. vol.)
Release time ⁶⁾	Max.: 10ms

Ambient temperature	HFKJ: -40°C to 85°C HFKJ-T: -40°C to 125°C	
Vibration resistance	Functional ⁷⁾	10Hz to 100Hz 44.1m/s ²
	Destructive	10Hz to 500Hz 44.1m/s ² , 2h
Shock resistance	Functional ⁷⁾	100m/s ² (pulse duration: 11ms)
	Destructive	1000m/s ² (pulse duration: 6ms)
Termination	PCB ⁸⁾	
Construction	Plastic sealed, Flux proofed	
Unit weight	Twin relay: Approx. 6.5g	

1) Equivalent to the max. initial contact resistance is 100mΩ (at 1A 6VDC).
2) Test under the following conditions:

a) The relay is mounted on the PCB, the coil is applied with 100% rated voltage;

b) The PCB board is a double layer board, the thickness of the copper foil is 4oz(140μm), the width of each copper foil is 3.76x(±5%)mm, the length of copper foil is 50mm±1mm and the Tg value of the PCB board is 150°C.

3) 23°C 14VDC(100 cycles resistive load)

4) This value can change due to the switching frequency, environmental conditions and desired reliability level, therefore it is recommended to check this with the actual load.

5) 1min, leakage current less than 1mA.

6) The value is measured when voltage drops suddenly from nominal voltage to 0 VDC and coil is not paralleled with suppression circuit.

7) When energized, opening time of NO contacts shall not exceed 10μs, when non-energized, opening time of NC contacts shall not exceed 10μs, meantime, NO contacts shall not be closed.

8) Since it is an environmental friendly product, please select lead-free solder when welding. The recommended soldering temperature and time is (260±3)°C, (5±0.3)s.

CONTACT DATA ³⁾

at 23°C

Load voltage	Load type ²⁾		Load current A		On/Off ratio		Electrical endurance OPS	Contact material	Load wiring diagram	
			2C		On s	Off s				
			NO	NC						
14VDC	Motor	Make ¹⁾	25	---	0.5	9.5	1 × 10 ⁵	AgSnO ₂	See diagram 2	
		Break	25	---						
	Simulate motor operation	Make ¹⁾	25	---	0.02	9.5				2 × 10 ⁵
		Transient	15	---	0.03					
		Break	5	---	0.45					



HONGFA RELAY

ISO9001, ISO/TS16949, ISO14001, OHSAS18001, IECQ QC 080000 CERTIFIED

2018 Rev. 1.00

- Notes:** 1) Corresponds to the peak inrush current on initial actuation (motor).
 2) The load wiring diagrams are listed below:

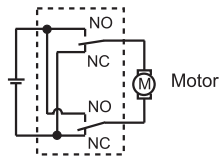

diagram 1

- 3) When the load requirement is different from content of the table above, please contact Hongfa for relay application support.

COIL DATA

Nominal voltage VDC	Pick-up voltage VDC max.			Drop-out voltage VDC min.			Coil resistance $x(1\pm 10\%)\Omega$			Power consumption W
	23°C	85°C	125°C	23°C	85°C	125°C	23°C	85°C	125°C	23°C
12	≤6.5	≤8.1	≤9.1	≥0.8	≥1	≥1.13	160	199.7	225.3	0.9
12	≤7.7	≤9.6	≤10.9	≥0.8	≥1	≥1.13	220	274.6	309.8	0.655

ORDERING INFORMATION

	HFKJ / 12 -BZ S P T (XXX)
Type	HFKJ: Standard HFKJ-T: Reflow soldering version or high heat-resistant version
Coil voltage	12: 12VDC
Contact arrangement	BZ: 2 Form C (Twin(H-bridge) version)
Construction¹⁾	S: Plastic sealed Nil: Flux proofed
Coil power	P: 0.9W Nil: 0.655W
Contact material	T: AgSnO ₂
Special code²⁾	XXX: Customer special requirement Nil: Standard

Notes: 1) Contact is recommended for suitable condition and specifications if water cleaning or surface process is involved in assembling relays on PCB.

2) The customer special requirement express as special code after evaluating by Hongfa. e.g. (170) stands for flasher load.

Outline Dimensions

2 Form C (Twin(H-bridge) relay)

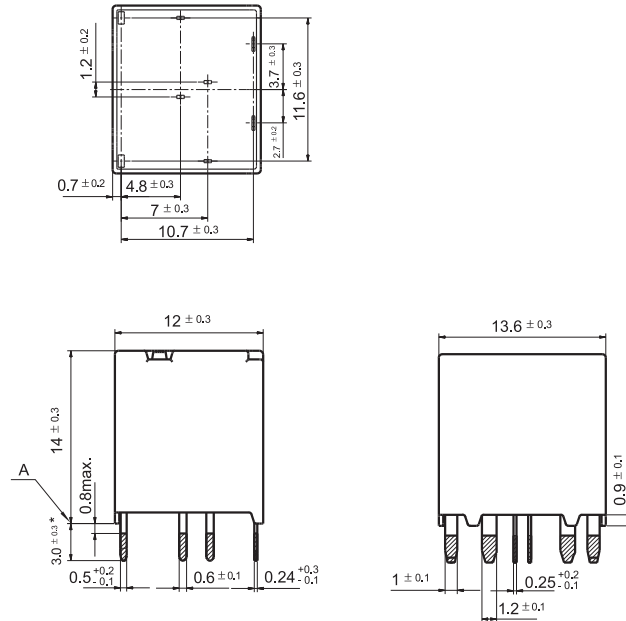

Remark: * The additional tin top is max. 1mm. Intervals between terminals is measured at A surface level.

PCB Layout (Bottom view)

2 Form C (Twin(H-bridge) relay)

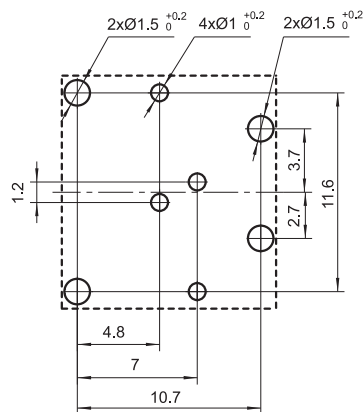

Undeclared tolerance: ± 0.1 .

Wiring Diagram (Bottom view)

2 Form C (Twin(H-bridge) relay)

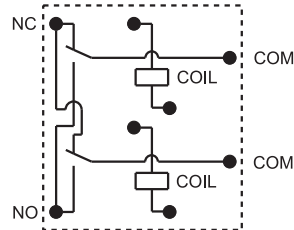

CHARACTERISTIC CURVES

(1) Coil temperature rise (23°C)

Experiment: HFKJ/12-BZSPT

Amount: three

Carrying current: 0A, 5A, 10A, 20A

Ambient temp.: 23°C

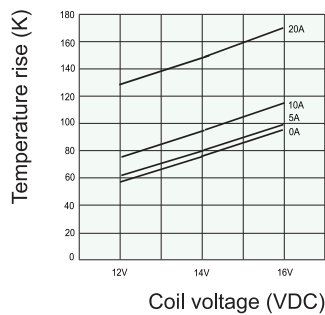

(2) Coil temperature rise (85°C)

Experiment: HFKJ/12-BZSPT

Amount: three

Carrying current: 0A, 5A, 10A, 15A

Ambient temp: 85°C

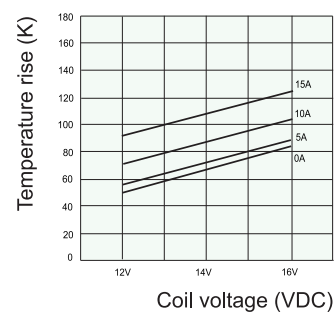

Remark: The PCB board is a double layer board. the thickness of the copper foil is 4oz(140μm), the width of each copper foil is 3.76X(1±5%)mm, the length of copper foil is 50mm±1mm.

Disclaimer

The specification is for reference only. See to "Terminology and Guidelines" for more information. Specifications subject to change without notice. In case there is specific criterion (such as mission profile, technical specification, PPAP etc.) checked and agreed by and between customer and Hongfa, this specific criterion should be taken as standard regarding any requirement on Hongfa product.

We could not evaluate all the performance and all the parameters for every possible application. Thus the user should be in a right position to choose the suitable product for their own application. If there is any query, please contact Hongfa for the technical service. However, it is the user's responsibility to determine which product should be used only.

© Xiamen Hongfa Electroacoustic Co., Ltd. All rights of Hongfa are reserved.