

HFV15-L

AUTOMOTIVE RELAY

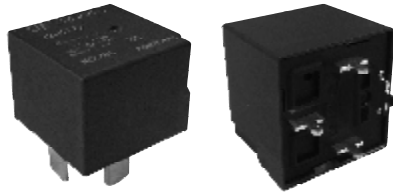

Typical Applications

Power Management, Fog lamp & headlight control, Rear window defogger, Air-conditioning, Fuel pump control, Cooling fan control, Battery disconnection device, Start / stop control

Features

- 40A switching capability
- Extended temp. range up to 125°C
- Max. continuous current 60A
- Max. making current 150A
- Plastic sealed and dust protected types available
- QC terminal and PCB terminal available
- RoHS & ELV compliant
- Pin assignment similar to ISO 7588 part 1

CHARACTERISTICS

Contact arrangement	1A	Shock resistance ^{5) 10)}	294m/s ²
Voltage drop	Typ.: 20mV (at 10A)	Flammability ⁶⁾	UL94-HB or better (meets FMVSS 302)
	Max.initial:100mV (at 10A)	Termination	QC, PCB ⁷⁾
	Max.after test: 250mV(at 10A)	Construction	Plastic sealed, Dust protected
Max. continuous current ^{1) 10)}	60A (at 23°C), 45A(at 85°C), 25A(at 125°C)	Unit weight	Approx. 35g
Max. switching current ¹⁰⁾	Make (NO): 150A ²⁾ Break (NO): 40A (Resistive, 13.5VDC)	Mechanical data ⁸⁾	housing retention (pull & push): 200N min. terminal retention (pull & push): 100N min. terminal resistance to bending (front & side): 10N min. ⁹⁾
Min. contact load	1A 6VDC		
Electrical endurance	See "CONTACT DATA"	1) For NO contacts, measured when applying 100% rated voltage on coil.	
Mechanical endurance	1 x 10 ⁶ OPS (60OPS/min)	2) Inrush peak current under lamp load, at 13.5VDC.	
Initial insulation resistance	100MΩ (at 500VDC)	3) 1min, leakage current less than 1mA.	
Dielectric strength ³⁾	500VAC	4) The value is measured when voltage drops suddenly from nominal voltage to 0 VDC and coil is not paralleled with suppression circuit.	
Operate time ¹⁰⁾	Typ:1.5ms,	5) When energized, opening time of NO contacts shall not exceed 100us,	
	Max.: 10ms (at nomi. vol.)	6) FMVSS: Federal Motor Vehicle Safety Standard.	
Release time ⁴⁾¹⁰⁾	Typ:1ms, Max.: 10ms	7) Since it is an environmental friendly product, please select lead-free solder when welding. The recommended soldering temperature and time is (250±3)°C , (5±0.3)s.	
Ambient temperature	-40°C to 125°C	8) Only valid for QC version.	
Vibration resistance ^{5) 10)}	5Hz to 22.3Hz 10mm DA	9) Test point is at 2mm away from terminal end, and after removing testing force, the terminal transfiguration shall not exceed 0.5mm.	
	22.3Hz to 500Hz 98m/s ²	10) Only for the 12VDC coil voltage type.	

CONTACT DATA ¹⁾

Load voltage	Load type		Load current A	On/Off ratio		Electrical endurance OPS	Contact material	Load wiring diagram ³⁾	Ambient temp.
				On s	Off s				
13.5VDC	Resistive	Make	40	2	2	1×10 ⁵	AgSnO ₂	See diagram 1	See Ambient Temp. Curve
		Break	40						
	Lamp	Make	150 ²⁾	2	2	1×10 ⁵	AgSnO ₂	See diagram 2	
		Break	30						
	Inductive (L=0.25mH)	Make	80	2	2	1×10 ⁵	AgSnO ₂	See diagram 3	
		Break	33						



HONGFA RELAY

ISO9001, ISO/TS16949, ISO14001, OHSAS18001, IECQ QC 080000 CERTIFIED

2018 Rev. 1.00

- 1) Loads mentioned in this chart is for relays with no parallel diode or Zener Diode. For those with parallel diode, Zener Diode or other components, please contact Hongfa for more technical supports.
Please also contact Hongfa if the actual application load is different from what mentioned above.
- 2) Corresponds to the peak inrush current on initial actuation (cold filament).
- 3) The load wiring diagrams are listed below (Ratings of NO, NC are tested based on different samples separately) :

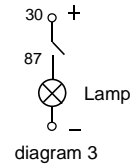
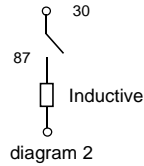
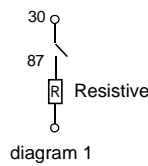

COIL DATA

at 23°C

Nominal voltage VDC	Set voltage ¹⁾ VDC max.	Reset voltage ¹⁾ VDC max.	Coil resistance x(1±10%) Ω	Max. allowable overdrive voltage ²⁾ VDC
12	7.2	7.2	25	18

- 1) The impulse width should be 10ms to 100ms. Energizing voltage mode should be acted as per the diagram below.

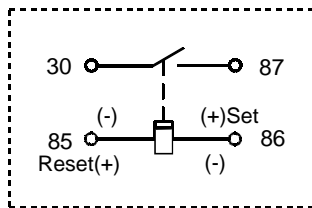

Polarity for set/reset energization	Set	Reset
	Pin85(-), Pin86(+)	Pin85(+), Pin86(-)

- 2) Max. allowable overdrive voltage is stated with no load applied and minimum coil resistance. Max. allowed inrush time is 1s.

ORDERING INFORMATION

	HFV15-L / 12 -H 1 S T J (XXX)
Type	HFV15-L:Latching
Coil voltage	12: 12VDC
Contact arrangement	H: 1 Form A
Version	1: QC Terminal 2: PCB type
Construction ¹⁾	S: Plastic sealed ²⁾ Nil: Dust protected
Contact material	T: AgSnO ₂
Terminal	J: QC Terminal without hole Nil: QC Terminal with hole, or PCB type
Special code ³⁾	XXX: Customer special requirement Nil: Standard

Notes: 1) Dust protected version is recommended.

2) Contact is recommended for suitable condition and specifications if water cleaning or surface process is involved in assembling relays on PCB.

3) The customer special requirement express as special code after evaluating by Hongfa. e.g. (170) stands for flasher load.

OUTLINE DIMENSIONS AND WIRING DIAGRAM

Unit: mm

Outline Dimensions

HFV15-L/12-H1□T□(XXX)

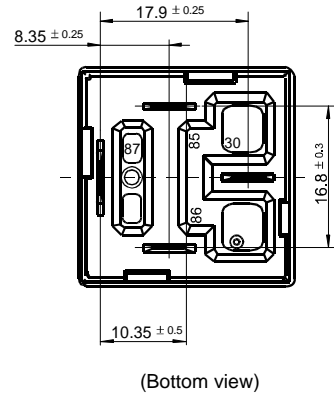
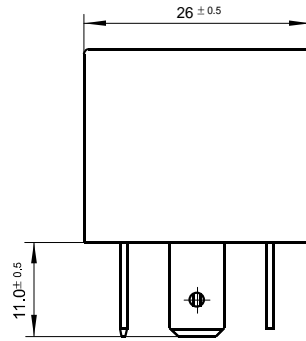
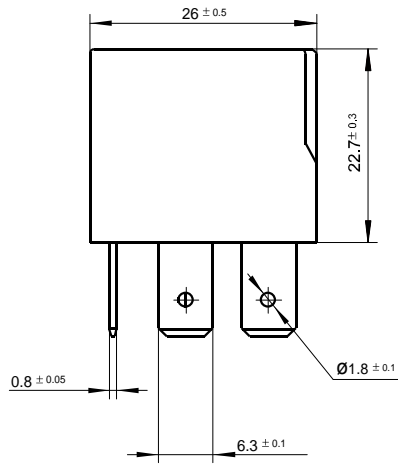

HFV15-L/12-H2□T□(XXX)

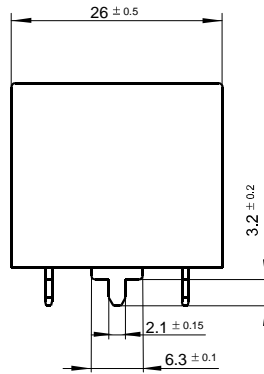
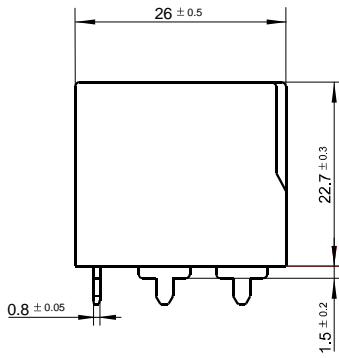

PCB Layout (Bottom view)

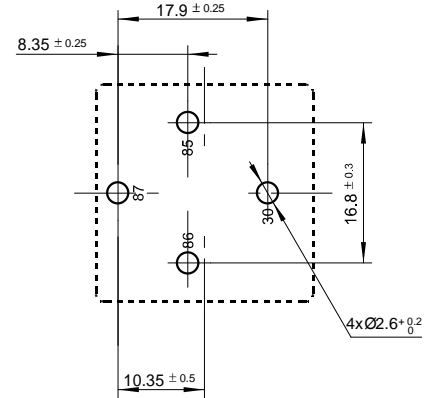

Wiring Diagram

HFV15-L/12-H□T□(XXX)

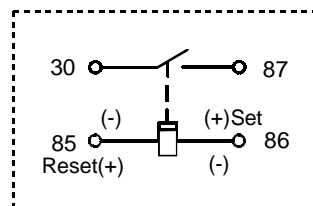

CHARACTERISTIC CURVES

Ambient temperature curve of the electrical endurance test

Ambient temp. curve (one cycle)

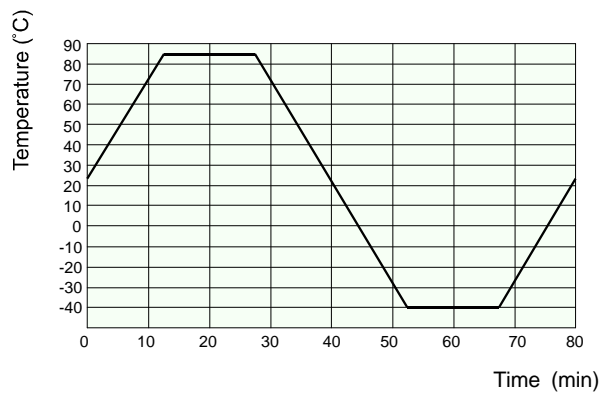

- 1) The minimum temperature is -40°C.
- 2) The maximum temperature is 85°C.

Disclaimer

The specification is for reference only. See to "Terminology and Guidelines" for more information. Specifications subject to change without notice. We could not evaluate all the performance and all the parameters for every possible application. Thus the user should be in a right position to choose the suitable product for their own application. If there is any query, please contact Hongfa for the technical service. However, it is the user's responsibility to determine which product should be used only.

© Xiamen Hongfa Electroacoustic Co., Ltd. All rights of Hongfa are reserved.