

SP-5400WA Advanced Display

SP5000 SERIES



Features:

- WVGA Display TFT Touch Panel
- 262,144 colors
- 12-24 Vdc input voltage
- 0-60C operating temperature
- Compatible with power or open box modules
- Embedded mounting clips for easy installation

Performance Specifications

Model	SP-5400WA	
Part Number	PFXSP5400WAD	PFXSP5400WADF0C
Graphics Display Resolution	800 x 480 pixels (WVGA)	
Display Type and Size	TFT Color LCD 7"	
Display Colors	262,144 colors	
Effective Display Area	W154.1 x H95.9 mm(W6.06 x H3.78 in.)	
Touch Screen	Resistive film (analog)	
Backlight	White LED (Not user replaceable. When replacement is required, contact your local distributor.)	
Backlight Service Life	50,000 hours or more (continuous operation at 25 °C [77 °F] before backlight brightness decreases to 50%)	
Brightness	Max.:400cd(Typ)Min.:4cd(Typ) 0...100 (Adjusted with touch panel or software) ^{*1}	
<small>*1 The maximum and minimum brightness Value is the reference Value, because there are individual differences by the liquid crystal.</small>		

General Specifications

Models	SP-5400WA	
Part Number	PFXSP5400WAD	PFXSP5400WADF0C
Conformal Coating	-	Yes
Input Voltage	12-24 Vdc (limits 10.8 -29.9 Vdc)	
Voltage Drop	12 Vdc: 1.25 ms or less/ 24 Vdc: 5 ms or less	
In-Rush Current	30 A or less	
Voltage Endurance	1,000 Vac, 20 mA for 1 minute (between charging and FG terminals)	
Insulation Resistance	500 Vdc, 10 MQ or more (between charging and FG terminals)	
Power Consumption ^{*1}	6.5W (max), 2 or less (When screen turns off the backlight (Standby Mode), 4W or less (when screen backlight 20%)	
Surrounding Air Temperature	0...60 °C [32...140 °F]	
Storage Temperature	-20...60 °C [-4...140 °F]	
Certifications	CE, RoHS, GOST-R, UL/c-UL, KC	
Ratings ^{*2}	IP66F, IP67F, TYPE 4X (Indoor Use Only)/13 (on the front panel when properly installed in an enclosure), ANSI/ISA 12.12.0 1, UL508, EN61000-6-4, EN61000-6-2, Class 1 Div 2 Groups A, B, C, and D	
Surrounding Air and Storage Humidity	10%...90% RH (Non condensing, wet bulb temperature 39 °C [102.2 °F] or less)	
Dust	0.1 mg/m3 (10-7 oz/ft3) or less (non-conductive levels)	
Pollution Degree	For use in Pollution Degree 2 environment	
Corrosive Gas	Free of corrosive gases	
Atmospheric Pressure (Operating Altitude)	800...1,114 hPa (2,000 m [6,561 ft] or lower)	
Vibration and Shock Resistance	IEC/EN 61131-2 compliant	
Electrostatic Discharge Immunity	Contact Discharge Method: 6 kV (IEC/EN 61000-4-2 Level 3)	
Weight ^{*5}	1.2kg (2.6 lb) or less	
External Dimensions ^{*3}	W203.6 x H148.6 x D36 mm(W8.02 x H5.85 x D1.42 in.)	
Panel Cut Dimensions	W190 x H135 mm(W7.48 x H5.31 in.) ^{*4} Panel thickness area:1.6...5 mm (0.06...0.2 in.)	
Warranty	Two (2) years	

*1 Power Consumption for Display Module only. *2 The front face of this product, installed in a solid panel, has been tested using conditions equivalent to the standard shown in the specification. *3 When combined with Box Module, the depth is 67mm (2.64 in.). *4 For dimensional tolerance, everything +1/0 mm (+0.04/0 in.) and R in angle are below R3 (R0.12 in.) *5 Weight for Display Module only

External Dimensions

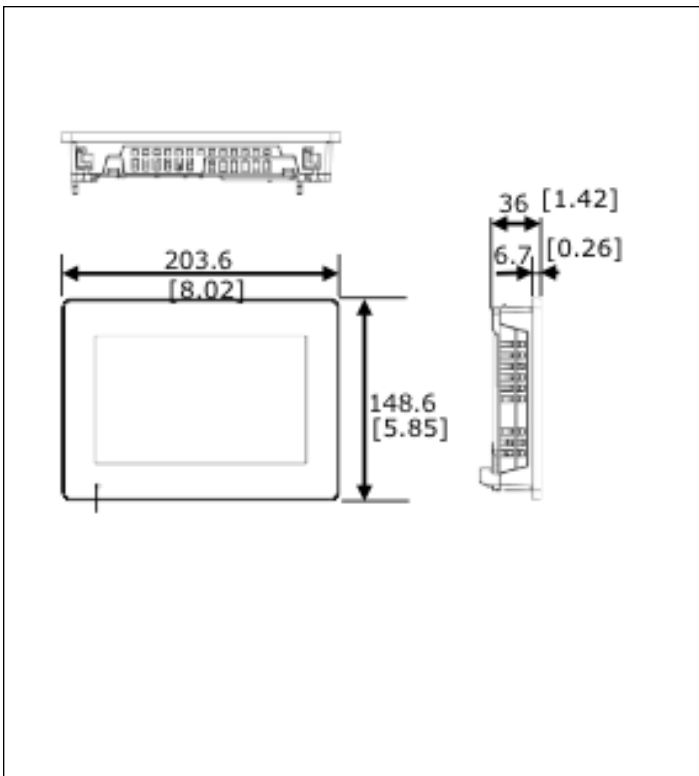

Panel-Cut Out Dimensions

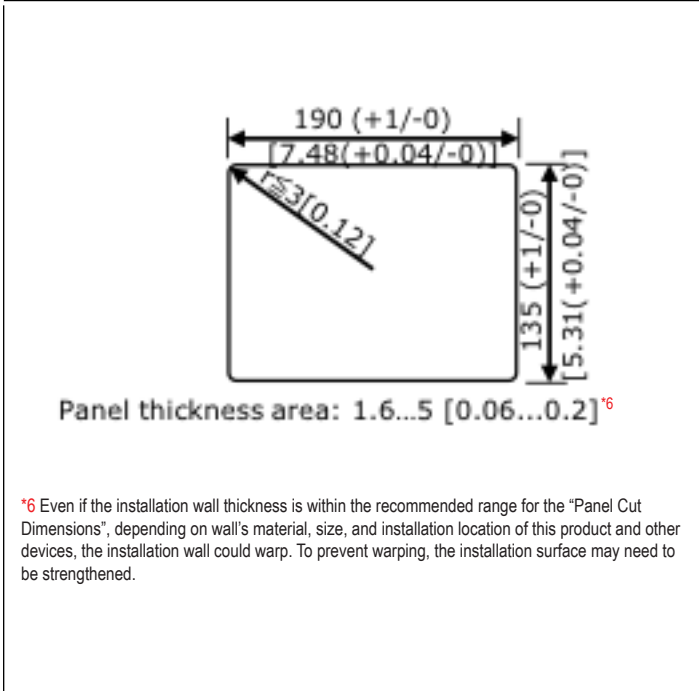

*6 Even if the installation wall thickness is within the recommended range for the "Panel Cut Dimensions", depending on wall's material, size, and installation location of this product and other devices, the installation wall could warp. To prevent warping, the installation surface may need to be strengthened.

Ordering Information

Type	Model Numbers	Description
SP-5400WA	PFXSP5400WAD	7-inch TFT, 262,144 colors, WVGA 800 x 480 pixels, Analog Touch Panel,
SP-5400WA with Conformal Coating	PFXSP5400WADF0C	7-inch TFT, 262,144 colors, WVGA 800 x 480 pixels, Analog Touch Panel, with conformal coating

Options

Part Number	Product Name	Description
PFXZCDAT72	Panel Cutout Adapter	Panel cutout adapter for mounting SP-5400WA in cutout for GP-2400, GP-3400, and GP-4400 Series
PFXZCDWG72	7.0-inch Wide Installation Gasket	Provides dust and moisture resistance when SP is installed into a solid panel (1 piece)
PFXZCDDS72	7-inch Wide Screen Protection Sheet.	Disposable, dirt-resistant sheet for SP unit's screen (5 sheets/set)

Modular Design and Easy Maintenance

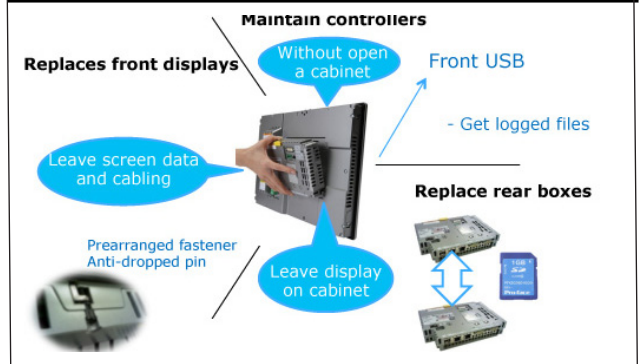

Pro-face America

Phone: 734.477.0600

Fax: 734.864.7347

www.profaceamerica.com

Customer Service Hotline: 800.289.9266

For more information

ACCESS

www.profaceamerica.com

Pro-face



California Proposition 65 Warning—Lead and Lead Compounds

Advertencia de la Proposición 65 de California—Plomo y compuestos de plomo

Avertissement concernant la Proposition 65 de Californie—Plomb et composés de plomb

⚠ WARNING: This product can expose you to chemicals including lead and lead compounds, which are known to the State of California to cause cancer and birth defects or other reproductive harm. For more information go to: www.P65Warnings.ca.gov.

⚠ ADVERTENCIA: Este producto puede exponerle a químicos incluyendo plomo y compuestos de plomo, que es (son) conocido(s) por el Estado de California como causante(s) de cáncer y defectos de nacimiento u otros daños reproductivos. Para mayor información, visite : www.P65Warnings.ca.gov.

⚠ AVERTISSEMENT: Ce produit peut vous exposer à des agents chimiques, y compris plomb et composés de plomb, identifiés par l'État de Californie comme pouvant causer le cancer et des malformations congénitales ou autres troubles de l'appareil reproducteur. Pour de plus amples informations, prière de consulter: www.P65Warnings.ca.gov.

All trademarks are the property of Schneider Electric SE, its subsidiaries, and affiliated companies.

Schneider Electric USA, Inc.
800 Federal Street
Andover, MA 01810 USA
888-778-2733
www.schneider-electric.us

Todas las marcas comerciales son propiedad de Schneider Electric SE, sus filiales y compañías afiliadas.

Importado en México por:
Schneider Electric México, S.A. de C.V.
Av. Ejercito Nacional No. 904
Col. Palmas, Polanco 11560 México, D.F.
55-5804-5000
www.schneider-electric.com.mx

Toutes les marques commerciales sont la propriété de Schneider Electric SE, ses filiales et compagnies affiliées.

Schneider Electric Canada, Inc.
5985 McLaughlin Road
Mississauga, ON L5R 1B8 Canada
800-565-6699
www.schneider-electric.ca