



HF-KP Series Servo Motor Specifications

Servo motor series		HF-KP series (Low inertia, small capacity)				
Servo motor model HF-KP		053(B)	13(B)	23(B)	43(B)	73(B)
Compatible servo amplifier model MR-J3-		10A(1)/B(1)(-RJ006)/T(1)		20A(1)/B(1)(-RJ006)/T(1)	40A(1)/B(1)(-RJ006)/T(1)	70A/B(-RJ006)/T
Power supply capacity (Note 1) (kVA)		0.3	0.3	0.5	0.9	1.3
Continuous running duty	Rated output (W)	50	100	200	400	750
	Rated torque (Note 9) (N·m [oz·in])	0.16 (22.7)	0.32 (45.3)	0.64 (90.6)	1.3 (184)	2.4 (340)
Maximum torque (when increased) (Note 8) (N·m [oz·in])		0.56 (79.3)	1.11 (157)	2.23 (316)	4.46 (632)	8.36 (1180)
Maximum torque (N·m [oz·in])		0.48 (68.0)	0.95 (135)	1.9 (269)	3.8 (538)	7.2 (1020)
Rated speed (r/min)		3000				
Maximum speed (r/min)		6000				
Permissible instantaneous speed (r/min)		6900				
Power rate at continuous rated torque (kW/s)		4.87	11.5	16.9	38.6	39.9
Rated current (A)		0.9	0.8	1.4	2.7	5.2
Maximum current (when increased) (Note 8) (A)		3.1	2.8	4.9	9.5	18.2
Maximum current (A)		2.7	2.4	4.2	8.1	15.6
Regenerative braking frequency (times/min) (Note 2)		(Note 3)	(Note 3)	448	249	140
Moment of inertia J ($\times 10^{-4}$ kg·m ²) [J (oz·in ²)]	Standard	0.052 (0.284)	0.088 (0.481)	0.24 (1.31)	0.42 (2.30)	1.43 (7.82)
	With electromagnetic brake	0.054 (0.295)	0.090 (0.492)	0.31 (1.69)	0.50 (2.73)	1.63 (8.91)
Recommended load to motor inertia moment ratio (Note 4)		15 times maximum		24 times maximum	22 times maximum	15 times maximum
Speed/position detector		18-bit encoder (resolution: 262144 p/rev)				
Attachments		— (Motors with an oil seal are available (HF-KPMJ))				
Insulation class		Class B				
Structure		Totally enclosed non ventilated (IP rating: IP65) (Note 5)				
Environment (Note 7)	Ambient temperature	0 to 40°C (32 to 104°F) (non freezing), storage: -15 to 70°C (5 to 158°F) (non freezing)				
	Ambient humidity	80% RH maximum (non condensing), storage: 90% RH maximum (non condensing)				
	Atmosphere	Indoors (no direct sunlight); no corrosive gas, inflammable gas, oil mist or dust				
	Elevation	1000m or less above sea level				
	Vibration (Note 6)	X: 49m/s ² Y: 49m/s ²				
Mass (kg [lb])	Standard	0.35 (0.78)	0.56 (1.3)	0.94 (2.1)	1.5 (3.3)	2.9 (6.4)
	With electromagnetic brake	0.65 (1.5)	0.86 (1.9)	1.6 (3.6)	2.1 (4.7)	3.9 (8.6)

Notes: 1. The power supply capacity varies depending on the power supply's impedance.

2. The regenerative braking frequency shows the permissible frequency when the motor, without a load and an optional regeneration unit, decelerates from the rated speed to a stop. When a load is connected; however, the value will be the table value/(m+1), where m=load inertia moment/motor inertia moment. When the operating speed exceeds the rated speed, the regenerative braking frequency is inversely proportional to the square of (operating speed/rated speed). If the operating speed changes frequently or when the regeneration is constant (as with vertical feeds), find the regenerative heating value (W) in operation. Provisions must be made to keep this heating value below the tolerable regenerative power (W). Optimal regenerative resistor varies for each system. Select the most suitable regenerative resistor by using the capacity selection software. Refer to the section "Options" for optional regeneration unit" in this catalog for details on the tolerable regenerative power (W).

3. When the motor decelerates to a stop from the rated speed, the regenerative frequency will not be limited if the effective torque is within the rated torque range. When the motor decelerates to a stop from the maximum speed, the regenerative frequency will not be limited if the effective torque is within the rated torque range and if the load to motor inertia moment is 8 times or less for HF-KP053(B) or 4 times or less for HF-KP13(B).

4. Contact your local sales office if the load to motor inertia moment ratio exceeds the value in the table.

5. The shaft-through portion is excluded.

6. The vibration direction is shown in the diagram to the right. The numeric value indicates the maximum value of the component (commonly the bracket in the opposite direction of the motor shaft). Fretting of the bearing occurs easily when the motor stops, so maintain vibration to approximately one-half of the allowable value.

7. In the environment where the servo motor is exposed to oil mist, oil and/or water, a standard specification servo motor may not be usable. Contact your local sales office for more details.

8. The maximum torque can be increased from 300% to 350% of the rated torque by setting servo amplifier's parameter. Refer to "Combinations for Increasing the Maximum Torque" in this catalog for more details.

9. When unbalanced torque is generated, such as in a vertical lift machine, it is recommended that the unbalanced torque of the machine be kept under 70% of the motor's rated torque.



HF-KP Series Servo Motor Torque Characteristics

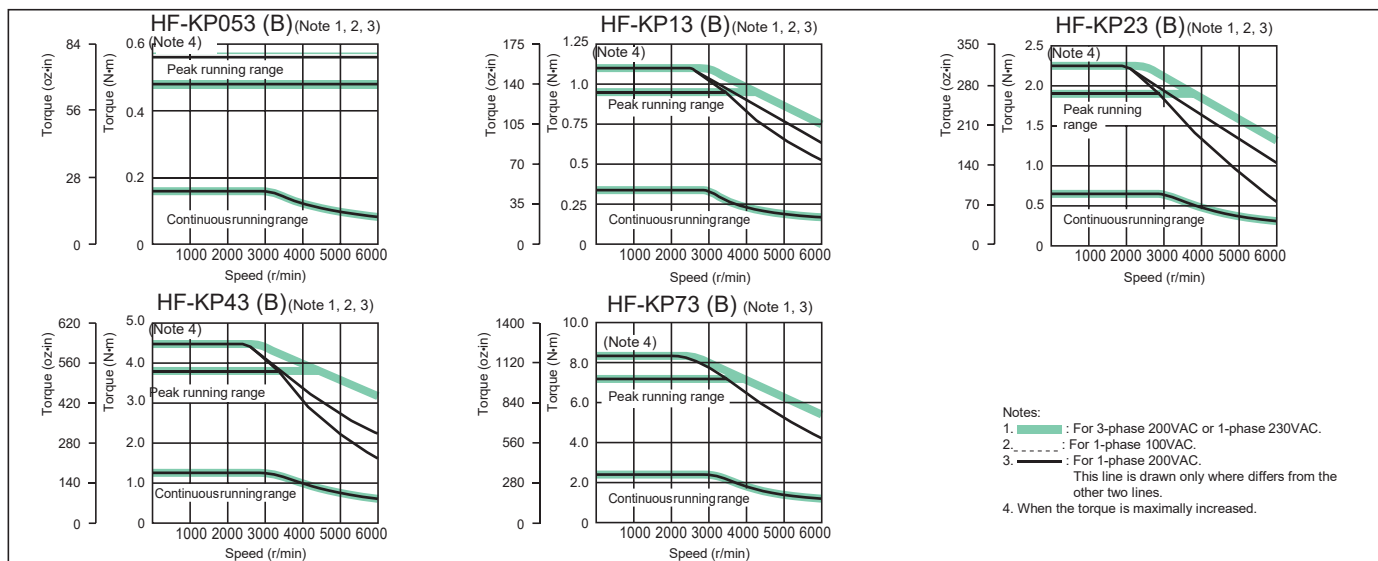

Model designation

Servo motors

Servo amplifiers

Options

Peripheral equipment

MR-J3-B Safety

MR-J3W series

MR-J3W series

Servo support software

Cautions

Warranty

Global FA centers



HF-MP Series Servo Motor Specifications

Servo motor series		HF-MP series (Ultra-low inertia, small capacity)				
Servo motor model HF-MP		053(B)	13(B)	23(B)	43(B)	73(B)
Compatible servo amplifier model (Note 7) MR-J3-		10A(1)/B(1)(-RJ006)/T(1)		20A(1)/B(1)(-RJ006)/T(1)	40A(1)/B(1)(-RJ006)/T(1)	70A/B(-RJ006)/T
Power supply capacity (Note 1) (kVA)		0.3	0.3	0.5	0.9	1.3
Continuous running duty	Rated output (W)	50	100	200	400	750
	Rated torque (Note 9) (N·m [oz·in])	0.16 (22.7)	0.32 (45.3)	0.64 (90.6)	1.3 (184)	2.4 (340)
Maximum torque (N·m [oz·in])		0.48 (68.0)	0.95 (135)	1.9 (269)	3.8 (538)	7.2 (1020)
Rated speed (r/min)		3000				
Maximum speed (r/min)		6000				
Permissible instantaneous speed (r/min)		6900				
Power rate at continuous rated torque (kW/s)		13.3	31.7	46.1	111.6	95.5
Rated current (A)		1.1	0.9	1.6	2.7	5.6
Maximum current (A)		3.2	2.8	5.0	8.6	16.7
Regenerative braking frequency (times/min) (Note 2)		(Note 3)	(Note 3)	1570	920	420
Moment of inertia J ($\times 10^{-4}$ kg·m ²) [J (oz·in ²)]	Standard	0.019 (0.104)	0.032 (0.175)	0.088 (0.481)	0.15 (0.820)	0.60 (3.28)
	With electromagnetic brake	0.025 (0.137)	0.039 (0.213)	0.12 (0.656)	0.18 (0.984)	0.70 (3.83)
Recommended load to motor inertia moment ratio		Maximum of 30 times the servo motor's inertia moment (Note 4)				
Speed/position detector		18-bit encoder (resolution: 262144 p/rev)				
Attachments		—	— (Motors with an oil seal are available (HF-MPMJ))			
Insulation class		Class B				
Structure		Totally enclosed non ventilated (IP rating: IP65) (Note 5)				
Environment (Note 8)	Ambient temperature	0 to 40°C (32 to 104°F) (non freezing), storage: -15 to 70°C (5 to 158°F) (non freezing)				
	Ambient humidity	80% RH maximum (non condensing), storage: 90% RH maximum (non condensing)				
	Atmosphere	Indoors (no direct sunlight); no corrosive gas, inflammable gas, oil mist or dust				
	Elevation	1000m or less above sea level				
	Vibration (Note 6)	X: 49m/s ² Y: 49m/s ²				
Mass (kg [lb])	Standard	0.35 (0.78)	0.56 (1.3)	0.94 (2.1)	1.5 (3.3)	2.9 (6.4)
	With electromagnetic brake	0.65 (1.5)	0.86 (1.9)	1.6 (3.6)	2.1 (4.7)	3.9 (8.6)

Notes: 1. The power supply capacity varies depending on the power supply's impedance.

2. The regenerative braking frequency shows the permissible frequency when the motor, without a load and an optional regeneration unit, decelerates from the rated speed to a stop. When a load is connected; however, the value will be the table value/(m+1), where m=load inertia moment/motor inertia moment. When the operating speed exceeds the rated speed, the regenerative braking frequency is inversely proportional to the square of (operating speed/rated speed). If the operating speed changes frequently or when the regeneration is constant (as with vertical feeds), find the regenerative heating value (W) in operation. Provisions must be made to keep this heating value below the tolerable regenerative power (W). Optimal regenerative resistor varies for each system. Select the most suitable regenerative resistor by using the capacity selection software. Refer to the section "Options ● Optional regeneration unit" in this catalog for details on the tolerable regenerative power (W).

3. When the motor decelerates to a stop from the maximum speed, the regenerative frequency will not be limited if the effective torque is within the rated torque range. When the motor decelerates to a stop from the maximum speed, the regenerative frequency will not be limited if the effective torque is within the rated torque range and if the load to motor inertia moment is 26 times or less for HF-MP053(B) or 15 time or less for HF-MP13(B).

4. Contact your local sales office if the load to motor inertia moment ratio exceeds the value in the table.

5. The shaft-through portion is excluded.

6. The vibration direction is shown in the diagram to the right. The numeric value indicates the maximum value of the component (commonly the bracket in the opposite X direction of the motor shaft). Fretting of the bearing occurs easily when the motor stops, so maintain vibration to approximately one-half of the allowable value.

7. To use MR-J3-MA(1) with the HF-MP series, the servo amplifier's software version must be A4 or above.

8. In the environment where the servo motor is exposed to oil mist, oil and/or water, a standard specification servo motor may not be usable. Contact your local sales office for more details.

9. When unbalanced torque is generated, such as in a vertical lift machine, it is recommended that the unbalanced torque of the machine be kept under 70% of the motor's rated torque.



HF-MP Series Servo Motor Torque Characteristics

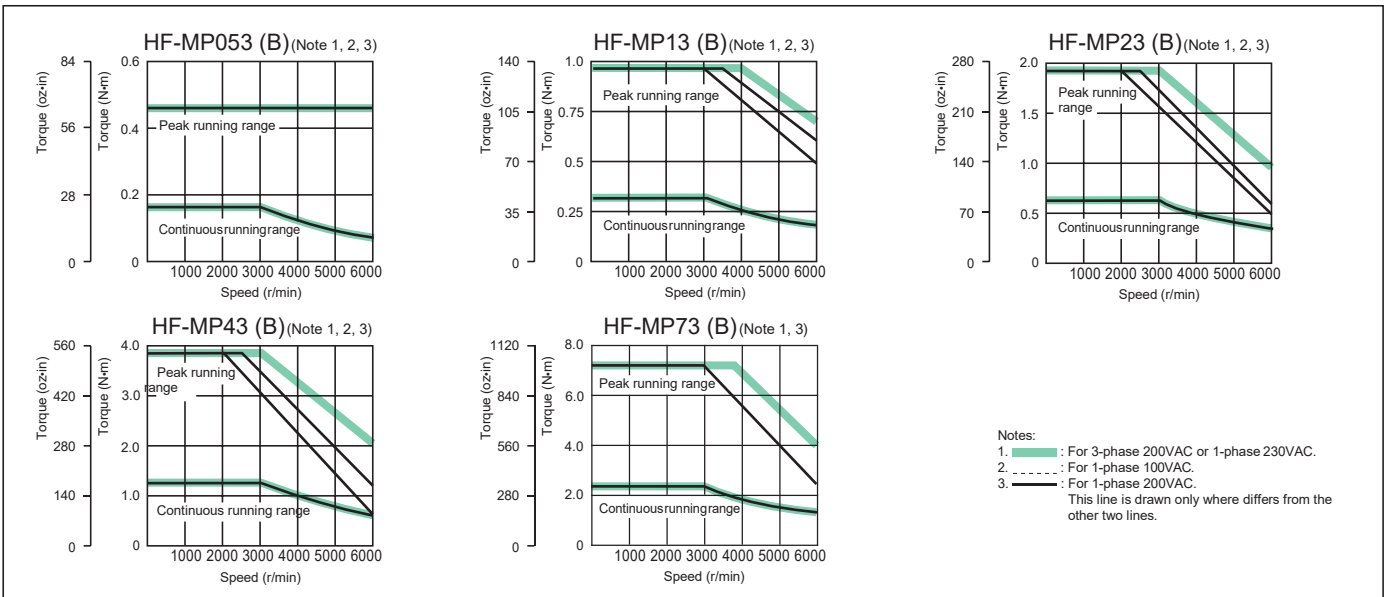

Servo motor series		HF-SP 1000r/min series (Medium inertia, medium capacity)					
Servo motor model HF-SP		51(B)	81(B)	121(B)	201(B)	301(B)	421(B)
Compatible servo amplifier model MR-J3-		60A/B(-RJ006)/T (Note 6)	100A/B(-RJ006)/T (Note 6)	200AN/BN(-RJ006)/TN (Note 6)		350A/B(-RJ006)/T	500A/B(-RJ006)/T
Power supply capacity (Note 1) (kVA)		1.0	1.5	2.1	3.5	4.8	6.3
Continuous running duty	Rated output (kW)	0.5	0.85	1.2	2.0	3.0	4.2
	Rated torque (Note 8) (N·m [oz·in])	4.77 (675)	8.12 (1150)	11.5 (1630)	19.1 (2700)	28.6 (4050)	40.1 (5680)
Maximum torque (N·m [oz·in])		14.3 (2020)	24.4 (3460)	34.4 (4870)	57.3 (8110)	85.9 (12200)	120 (17000)
Rated speed (r/min)		1000					
Maximum speed (r/min)		1500					
Permissible instantaneous speed (r/min)		1725					
Power rate at continuous rated torque (kW/s)		19.2	37.0	34.3	48.6	84.6	104
Rated current (A)		2.9	4.5	6.5	11	16	24
Maximum current (A)		8.7	13.5	19.5	33	48	72
Regenerative braking frequency (times/min) (Note 2)		36	90	188	105	84	75
Moment of inertia J ($\times 10^{-4}$ kg·m ²) [J (oz·in ²)]	Standard	11.9 (65.1)	17.8 (97.3)	38.3 (209)	75.0 (410)	97.0 (530)	154 (842)
	With electromagnetic brake	14.0 (76.5)	20.0 (109)	47.9 (262)	84.7 (463)	107 (585)	164 (897)
Recommended load to motor inertia moment ratio		Maximum of 15 times the servo motor's inertia moment (Note 3)					
Speed/position detector		18-bit encoder (resolution: 262144 p/rev)					
Attachments		— (Motors with an oil seal are available (HF-SPMJ))					
Insulation class		Class F					
Structure		Totally enclosed non ventilated (IP rating: IP67) (Note 4)					
Environment (Note 7)	Ambient temperature	0 to 40°C (32 to 104°F) (non freezing), storage: -15 to 70°C (5 to 158°F) (non freezing)					
	Ambient humidity	80% RH maximum (non condensing), storage: 90% RH maximum (non condensing)					
	Atmosphere	Indoors (no direct sunlight); no corrosive gas, inflammable gas, oil mist or dust					
	Elevation	1000m or less above sea level					
	Vibration (Note 5)	X: 24.5m/s ² Y: 24.5m/s ²		X: 24.5m/s ² Y: 49m/s ²		X: 24.5m/s ² Y: 29.4m/s ²	
Mass (kg [lb])	Standard	6.5 (15)	8.3 (19)	12 (27)	19 (42)	22 (49)	32 (71)
	With electromagnetic brake	8.5 (19)	10.3 (23)	18 (40)	25 (56)	28 (62)	38 (84)

- Notes: 1. The power supply capacity varies depending on the power supply's impedance.
 2. The regenerative braking frequency shows the permissible frequency when the motor, without a load and an optional regeneration unit, decelerates from the rated speed to a stop. When a load is connected; however, the value will be the table value/(m+1), where m=load inertia moment/motor inertia moment. When the operating speed exceeds the rated speed, the regenerative braking frequency is inversely proportional to the square of (operating speed/rated speed). If the operating speed changes frequently or when the regeneration is constant (as with vertical feeds), find the regenerative heating value (W) in operation. Provisions must be made to keep this heating value below the tolerable regenerative power (W). Optimal regenerative resistor varies for each system. Select the most suitable regenerative resistor by using the capacity selection software. Refer to the section "Options ● Optional regeneration unit" in this catalog for details on the tolerable regenerative power (W).
 3. Contact your local sales office if the load to motor inertia moment ratio exceeds the value in the table.
 4. The shaft-through portion is excluded.
 5. The vibration direction is shown in the diagram to the right. The numeric value indicates the maximum value of the component (commonly the bracket in the opposite x direction of the motor shaft). Fretting of the bearing occurs easily when the motor stops, so maintain vibration to approximately one-half of the allowable value.
 6. To use MR-J3-200A or smaller with the HF-SP 1000r/min series, the servo amplifier's software version must be A4 or above.
 7. In the environment where the servo motor is exposed to oil mist, oil and/or water, a standard specification servo motor may not be usable. Contact your local sales office for more details.
 8. When unbalanced torque is generated, such as in a vertical lift machine, it is recommended that the unbalanced torque of the machine be kept under 70% of the motor's rated torque.



HF-SP 1000r/min Series Servo Motor Torque Characteristics

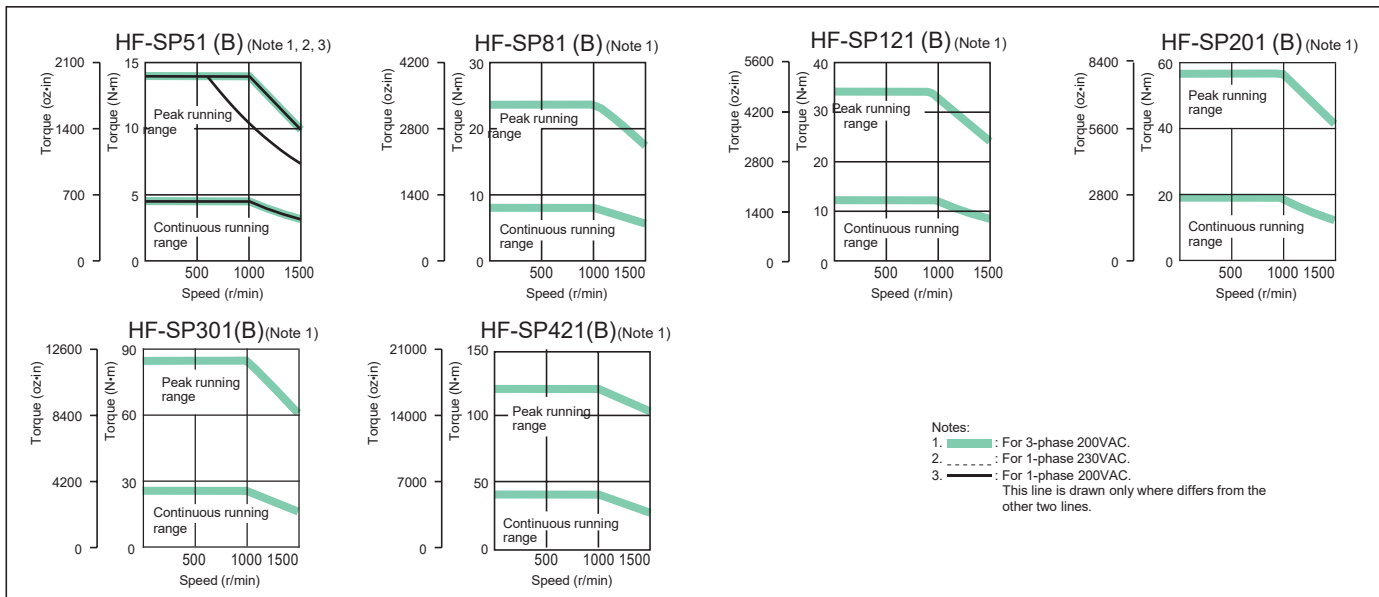

MELSERVO-J3



HF-SP 2000r/min Series Servo Motor Specifications (200VAC Class)

Servo motor series		HF-SP 2000r/min series (Medium inertia, medium capacity)						
Servo motor model HF-SP		52(B)	102(B)	152(B)	202(B)	352(B)	502(B)	702(B)
Compatible servo amplifier model MR-J3-		60A/B(-RJ006)/T	100A/B(-RJ006)/T	200AN/BN(-RJ006)/TN	350A/B(-RJ006)/T	500A/B(-RJ006)/T	700A/B(-RJ006)/T	
Power supply capacity (Note 1) (kVA)		1.0	1.7	2.5	3.5	5.5	7.5	10
Continuous running duty	Rated output (kW)	0.5	1.0	1.5	2.0	3.5	5.0	7.0
	Rated torque (Note 7) (N·m [oz·in])	2.39 (338)	4.77 (675)	7.16 (1010)	9.55 (1350)	16.7 (2360)	23.9 (3380)	33.4 (4730)
Maximum torque (N·m [oz·in])		7.16 (1010)	14.3 (2020)	21.5 (3040)	28.6 (4050)	50.1 (7090)	71.6 (10100)	100 (14200)
Rated speed (r/min)		2000						
Maximum speed (r/min)		3000						
Permissible instantaneous speed (r/min)		3450						
Power rate at continuous rated torque (kW/s)		9.34	19.2	28.8	23.8	37.2	58.8	72.5
Rated current (A)		2.9	5.3	8.0	10	16	24	33
Maximum current (A)		8.7	15.9	24	30	48	72	99
Regenerative braking frequency (times/min) (Note 2)		60	62	152	71	33	37	31
Moment of inertia J ($\times 10^{-4}$ kg·m ²) [J (oz·in ²)]	Standard	6.1 (33.4)	11.9 (65.1)	17.8 (97.3)	38.3 (209)	75.0 (410)	97.0 (530)	154 (842)
	With electromagnetic brake	8.3 (45.4)	14.0 (76.5)	20.0 (109)	47.9 (262)	84.7 (463)	107 (585)	164 (897)
Recommended load to motor inertia moment ratio		Maximum of 15 times the servo motor's inertia moment (Note 3)						
Speed/position detector		18-bit encoder (resolution: 262144 p/rev)						
Attachments		— (Motors with an oil seal are available (HF-SPMJ))						
Insulation class		Class F						
Structure		Totally enclosed non ventilated (IP rating: IP67) (Note 4)						
Environment (Note 6)	Ambient temperature	0 to 40°C (32 to 104°F) (non freezing), storage: -15 to 70°C (5 to 158°F) (non freezing)						
	Ambient humidity	80% RH maximum (non condensing), storage: 90% RH maximum (non condensing)						
	Atmosphere	Indoors (no direct sunlight); no corrosive gas, inflammable gas, oil mist or dust						
	Elevation	1000m or less above sea level						
	Vibration (Note 5)	X: 24.5m/s ² Y: 24.5m/s ²			X: 24.5m/s ² Y: 49m/s ²		X: 24.5m/s ² Y: 29.4m/s ²	
Mass (kg [lb])	Standard	4.8 (11)	6.5 (15)	8.3 (19)	12 (27)	19 (42)	22 (49)	32 (71)
	With electromagnetic brake	6.7 (15)	8.5 (19)	10.3 (23)	18 (40)	25 (56)	28 (62)	38 (84)

Notes: 1. The power supply capacity varies depending on the power supply's impedance.

2. The regenerative braking frequency shows the permissible frequency when the motor, without a load and an optional regeneration unit, decelerates from the rated speed to a stop. When a load is connected; however, the value will be the table value/(m+1), where m=load inertia moment/motor inertia moment. When the operating speed exceeds the rated speed, the regenerative braking frequency is inversely proportional to the square of (operating speed/rated speed). If the operating speed changes frequently or when the regeneration is constant (as with vertical feeds), find the regenerative heating value (W) in operation. Provisions must be made to keep this heating value below the tolerable regenerative power (W). Optimal regenerative resistor varies for each system. Select the most suitable regenerative resistor by using the capacity selection software. Refer to the section "Options ● Optional regeneration unit" in this catalog for details on the tolerable regenerative power (W).

HF-SP 2000r/min Series Servo Motor Torque Characteristics (200VAC Class)

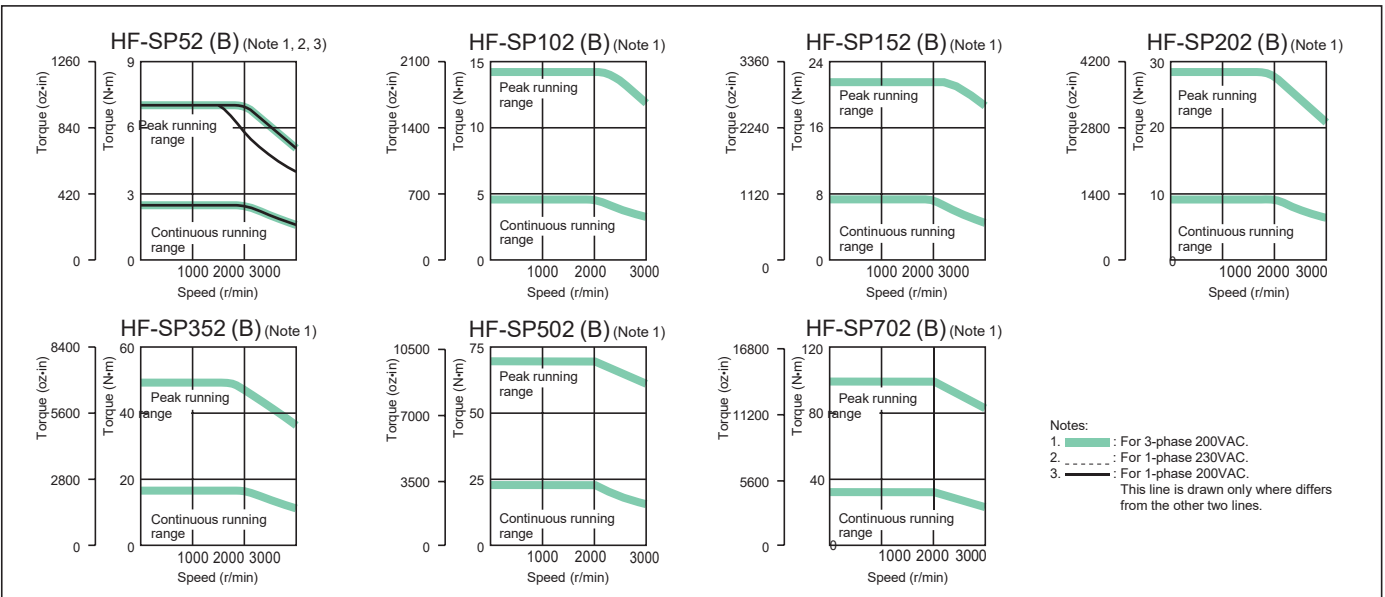

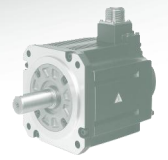

HF-SP 2000r/min Series Servo Motor Specifications (400VAC Class)

HF-SP 2000r/min series (Medium inertia, medium capacity)						
524(B)	1024(B)	1524(B)	2024(B)	3524(B)	5024(B)	7024(B)
60A4/B4(-RJ006)/T4	100A4/B4(-RJ006)/T4	200A4/B4(-RJ006)/T4		350A4/B4(-RJ006)/T4	500A4/B4(-RJ006)/T4	700A4/B4(-RJ006)/T4
1.0	1.7	2.5	3.5	5.5	7.5	10
0.5	1.0	1.5	2.0	3.5	5.0	7.0
2.39 (338)	4.77 (675)	7.16 (1010)	9.55 (1350)	16.7 (2360)	23.9 (3380)	33.4 (4730)
7.16 (1010)	14.3 (2020)	21.5 (3040)	28.6 (4050)	50.1 (7090)	71.6 (10100)	100 (14200)
2000						
3000						
3450						
9.34	19.2	28.8	23.8	37.2	58.8	72.5
1.5	2.9	4.1	5.0	8.4	12	16
4.5	8.7	12	15	25	36	48
90	46	154	72	37	34	28
6.1 (33.4)	11.9 (65.1)	17.8 (97.3)	38.3 (209)	75.0 (410)	97.0 (530)	154 (842)
8.3 (45.4)	14.0 (76.5)	20.0 (109)	47.9 (262)	84.7 (463)	107 (585)	164 (897)
Maximum of 15 times the servo motor's inertia moment (Note 3)						
18-bit encoder (resolution: 262144 p/rev)						
— (Motors with an oil seal are available (HF-SPMJ))						
Class F						
Totally enclosed non ventilated (IP rating: IP67) (Note 4)						
0 to 40°C (32 to 104°F) (non freezing), storage: -15 to 70°C (5 to 158°F) (non freezing)						
80% RH maximum (non condensing), storage: 90% RH maximum (non condensing)						
Indoors (no direct sunlight); no corrosive gas, inflammable gas, oil mist or dust						
1000m or less above sea level						
X: 24.5m/s ² Y: 24.5m/s ²		X: 24.5m/s ² Y: 49m/s ²			X: 24.5m/s ² Y: 29.4m/s ²	
4.8 (11)	6.7 (15)	8.5 (19)	13 (29)	19 (42)	22 (49)	32 (71)
6.7 (15)	8.6 (19)	11 (25)	19 (42)	25 (56)	28 (62)	38 (84)

3. Contact your local sales office if the load to motor inertia moment ratio exceeds the value in the table.
 4. The shaft-through portion is excluded.

5. The vibration direction is shown in the diagram to the right. The numeric value indicates the maximum value of the component (commonly the bracket in the opposite direction of the motor shaft). Fretting of the bearing occurs easily when the motor stops, so maintain vibration to approximately one-half of the allowable value.

6. In the environment where the servo motor is exposed to oil mist, oil and/or water, a standard specification servo motor may not be usable. Contact your local sales office for more details.

7. When unbalanced torque is generated, such as in a vertical lift machine, it is recommended that the unbalanced torque of the machine be kept under 70% of the motor's rated torque.

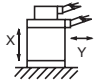

HF-SP 2000r/min Series Servo Motor Torque Characteristics (400VAC Class)

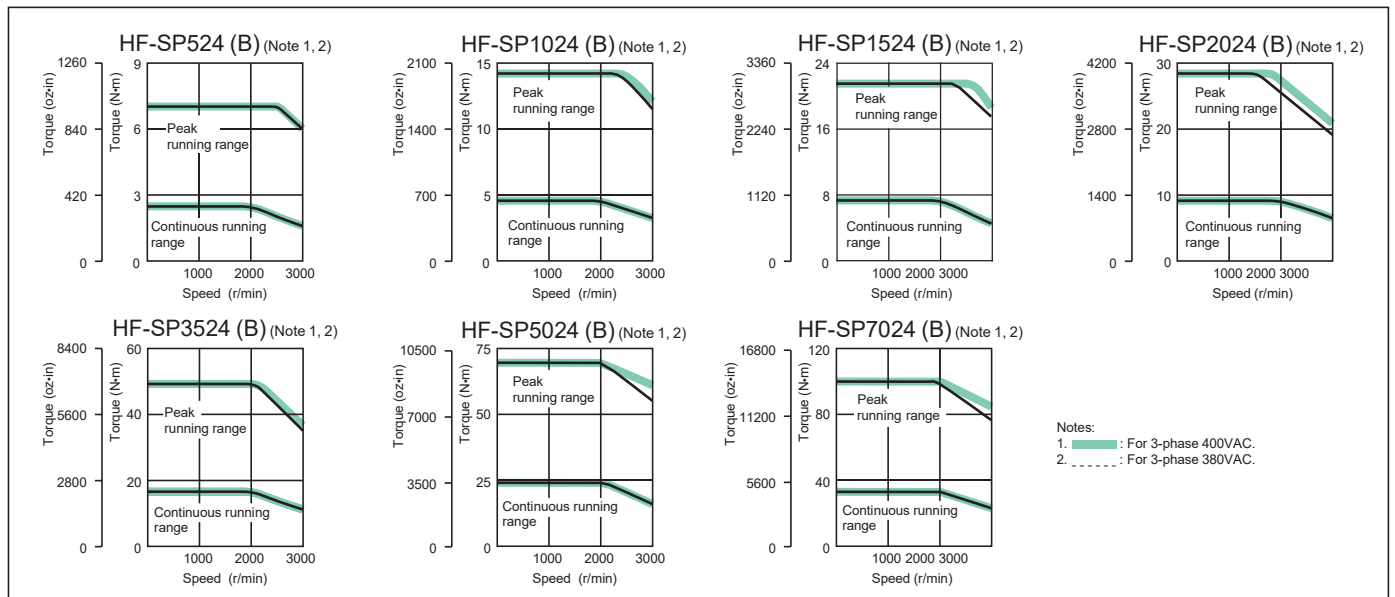

Model designation
 Servo motors
 Servo amplifiers
 Options
 Peripheral equipment
 MR-J3-B Safety
 MR-J3W series
 Servo support software
 Cautions
 Warranty
 Global FA centers

MELSERVO-J3

HF-JP 3000r/min Series Servo Motor Specifications (200VAC Class)

Servo motor series		HF-JP 3000r/min series (Low inertia, medium capacity)			
Servo motor model HF-JP		53(B)	73(B)	103(B)	153(B)
Compatible servo amplifier model MR-J3-		60A/B(-RJ006)/T	70A/B(-RJ006)/T	100A/B(-RJ006)/T	200AN/BN(-RJ006)/TN
Power supply capacity (Note 1) (kVA)		1.0	1.3	1.7	2.5
Continuous running duty	Rated output (kW)	0.5	0.75	1.0	1.5
	Rated torque (Note 10) (N·m [oz·in])	1.59 (225)	2.39 (338)	3.18 (450)	4.77 (675)
Maximum torque (N·m [oz·in])		4.77 (675)	7.16 (1010)	9.55 (1350)	14.3 (2020)
Rated speed (r/min)		3000			
Maximum speed (r/min)		6000			
Permissible instantaneous speed (r/min)		6900			
Power rate at continuous rated torque (kW/s)		16.7	27.3	38.2	60.2
Rated current (A)		3.0	5.6	5.6	10.6
Maximum current (A)		9.0	17	17	32
Regenerative braking frequency (times/min) (Note 2)		67	98	76	271
Moment of inertia J ($\times 10^{-4}$ kg·m ²) [J (oz·in ²)]	Standard	1.52 (8.31)	2.09 (11.4)	2.65 (14.5)	3.79 (20.7)
	With electromagnetic brake	2.02 (11.0)	2.59 (14.2)	3.15 (17.2)	4.29 (23.5)
Recommended load to motor inertia moment ratio		Maximum of 10 times the servo motor's inertia moment (Note 3)			
Speed/position detector		18-bit encoder (resolution: 262144 p/rev)			
Attachments		Oil seal			
Insulation class		Class F			
Structure		Totally enclosed non ventilated (IP rating: IP67) (Note 4)			
Environment (Note 6)	Ambient temperature	0 to 40°C (32 to 104°F) (non freezing), storage: -15 to 70°C (5 to 158°F) (non freezing)			
	Ambient humidity	80% RH maximum (non condensing), storage: 90% RH maximum (non condensing)			
	Atmosphere	Indoors (no direct sunlight); no corrosive gas, inflammable gas, oil mist or dust			
	Elevation	1000m or less above sea level			
	Vibration (Note 5)	X: 24.5m/s ² Y: 24.5m/s ²			
Mass (kg [lb])	Standard	3.0 (6.7)	3.7 (8.2)	4.5 (10)	5.9 (13)
	With electromagnetic brake	4.4 (9.7)	5.1 (12)	5.9 (13)	7.3 (16)
With increased maximum torque: (Note 8)	Compatible servo amplifier model MR-J3-	100A/B(-RJ006)/T (Note 11)	200AN/BN(-RJ006)/TN (Note 11)	200AN/BN(-RJ006)/TN (Note 11)	350A/B(-RJ006)/T (Note 11)
	Maximum torque (N·m [oz·in])	6.37 (902)	9.55 (1350)	12.7 (1800)	19.1 (2700)
	Maximum current (A)	12	23	23	43
	Regenerative braking frequency (times/min) (Note 2)	137	511	396	271

Notes: 1. The power supply capacity varies depending on the power supply's impedance.

2. The regenerative braking frequency shows the permissible frequency when the motor, without a load and an optional regeneration unit, decelerates from the rated speed to a stop. When a load is connected; however, the value will be the table value/(m+1), where m=load inertia moment/motor inertia moment. When the operating speed exceeds the rated speed, the regenerative braking frequency is inversely proportional to the square of (operating speed/rated speed). If the operating speed changes frequently or when the regeneration is constant (as with vertical feeds), find the regenerative heating value (W) in operation. Provisions must be made to keep this heating value below the tolerable regenerative power (W). Optimal regenerative resistor varies for each system. Select the most suitable regenerative resistor by using the capacity selection software. Refer to the section "Options ● Optional regeneration unit" in this catalog for details on the tolerable regenerative power (W).

3. Contact your local sales office if the load to motor inertia moment ratio exceeds the value in the table.

4. The shaft-through portion is excluded.

HF-JP 3000r/min Series Servo Motor Torque Characteristics (200VAC Class)

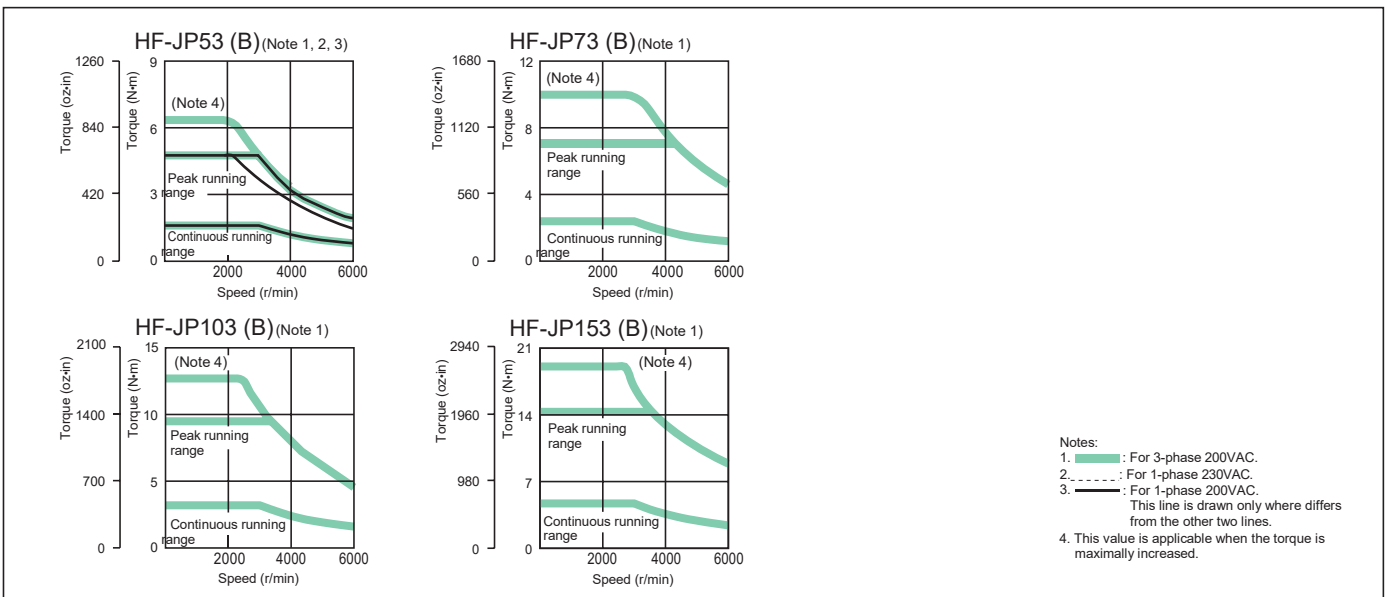

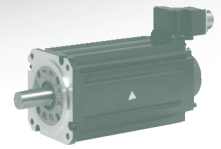

HF-JP 3000r/min series (Low inertia, medium capacity)				
203(B)	353(B)	503(B)	703(B)	903(B)
200AN/BN(-RJ006)/TN	350A/B(-RJ006)/T	500A/B(-RJ006)/T	700A/B(-RJ006)/T	11KA/B(-RJ006)/T
3.5	5.5	7.5	10	13
2.0	3.3 <3.5> (Note 7)	5.0	7.0	9.0
6.37 (902)	10.5 (1490) <11.1 (1570)> (Note 7)	15.9 (2250)	22.3 (3160)	28.6 (4050)
19.1 (2700)	32.0 (4530)	47.7 (6750)	66.8 (9460)	85.8 (12100)
		3000		
	6000		5000	
	6900		5750	
82.4	83.5	133	115	147
10.6	16.6 <17.6> (Note 7)	27	34	41
32	51	81	103	134
206	73	68	56	204 (Note 9)
4.92 (26.9)	13.2 (72.2)	19.0 (104)	43.3 (237)	55.8 (305)
5.42 (29.6)	15.4 (84.2)	21.2 (116)	52.9 (289)	65.4 (358)
Maximum of 10 times the servo motor's inertia moment (Note 3)				
18-bit encoder (resolution: 262144 p/rev)				
Oil seal				
Class F				
Totally enclosed non ventilated (IP rating: IP67) (Note 4)				
0 to 40°C (32 to 104°F) (non freezing), storage: -15 to 70°C (5 to 158°F) (non freezing)				
80% RH maximum (non condensing), storage: 90% RH maximum (non condensing)				
Indoors (no direct sunlight); no corrosive gas, inflammable gas, oil mist or dust				
1000m or less above sea level				
X: 24.5m/s ² Y: 24.5m/s ²			X: 24.5m/s ² Y: 29.4m/s ²	
7.5 (17)	13 (29)	18 (40)	29 (64)	36 (80)
8.9 (20)	15 (33)	20 (44)	35 (78)	42 (93)
350A/B(-RJ006)/T (Note 11)	500A/B(-RJ006)/T (Note 11)	700A/B(-RJ006)/T (Note 11)	-	-
25.5 (3610)	44.6 (6320)	63.7 (9020)	-	-
43	71	108	-	-
206	98	89	-	-

- The vibration direction is shown in the diagram to the right. The numeric value indicates the maximum value of the component (commonly the bracket in the opposite direction of the motor shaft). Fretting of the bearing occurs easily when the motor stops, so maintain vibration to approximately one-half of the allowable value.
- In the environment where the servo motor is exposed to oil mist, oil and/or water, a standard specification servo motor may not be usable. Contact your local sales office for more details.
- Value indicated in < > is applicable when connected to MR-J3-500A/B(-RJ006)/T servo amplifier.
- The value is applicable when the external regenerative resistors, GRZG400-M Ω (standard accessory) are used with cooling fans (2 units of 92 × 92mm, minimum air flow: 1.0m³/min). Note that change in parameter No. PA02 is required.
- The maximum torque can be increased from 300% to 400% of the rated torque by changing the servo amplifier to be combined. Refer to "Combinations for Increasing the Maximum Torque" in this catalog for more details.
- When unbalanced torque is generated, such as in a vertical lift machine, it is recommended that the unbalanced torque of the machine be kept under 70% of the motor's rated torque.
- Contact your local sales office for the unlisted servo amplifiers which enable increasing the maximum torque.

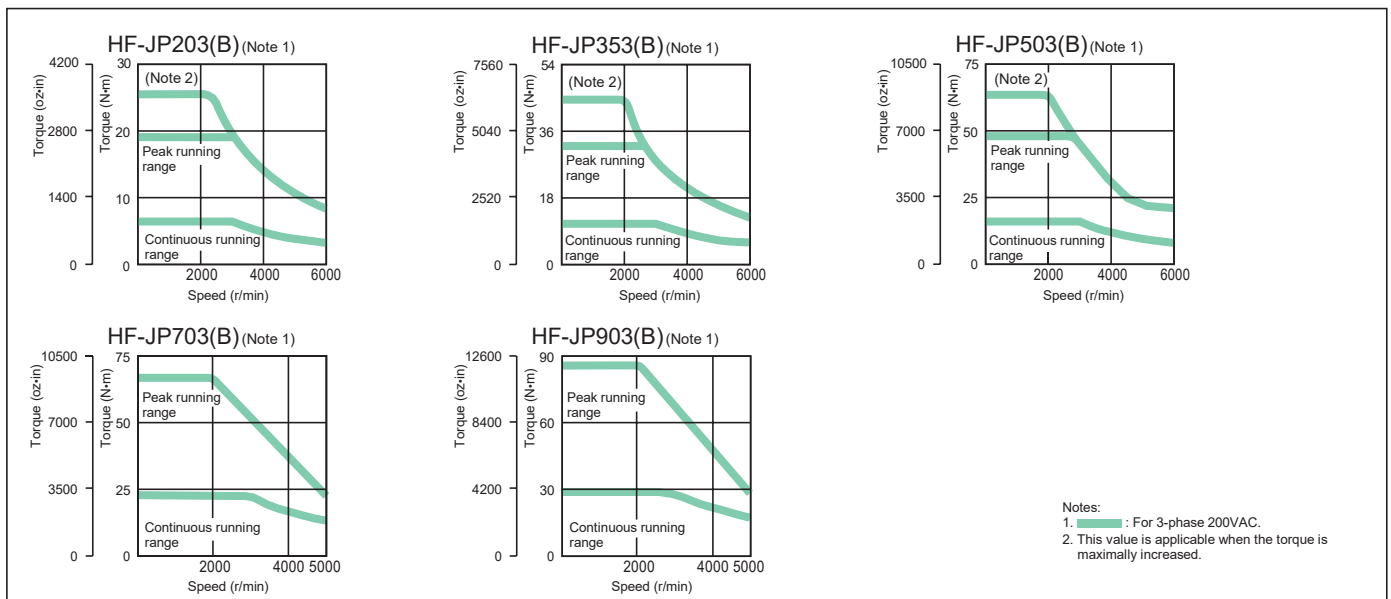
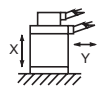

Model designation
Servo motors
Servo amplifiers
Options
Peripheral equipment
MR-J3-BSafety
MR-J3W series
Servo support software
Cautions
Warranty
Global FA centers

MELSERVO-J3

HF-JP 3000r/min Series Servo Motor Specifications (400VAC Class)

Servo motor series		HF-JP 3000r/min series (Low inertia, medium capacity)			
Servo motor model HF-JP		534(B)	734(B)	1034(B)	1534(B)
Compatible servo amplifier model MR-J3-		60A4/B4(-RJ006)/T4	100A4/B4(-RJ006)/T4		200A4/B4(-RJ006)/T4
Power supply capacity (Note 1) (kVA)		1.0	1.3	1.7	2.5
Continuous running duty	Rated output (kW)	0.5	0.75	1.0	1.5
	Rated torque (Note 10) (N·m [oz·in])	1.59 (225)	2.39 (338)	3.18 (450)	4.77 (675)
Maximum torque (N·m [oz·in])		4.77 (675)	7.16 (1010)	9.55 (1350)	14.3 (2020)
Rated speed (r/min)		3000			
Maximum speed (r/min)		6000			
Permissible instantaneous speed (r/min)		6900			
Power rate at continuous rated torque (kW/s)		16.7	27.3	38.2	60.2
Rated current (A)		1.5	2.8	2.8	5.4
Maximum current (A)		4.5	8.4	8.4	17
Regenerative braking frequency (times/min) (Note 2)		99	72	56	265
Moment of inertia J ($\times 10^{-4}$ kg·m ²) [J (oz·in ²)]	Standard	1.52 (8.31)	2.09 (11.4)	2.65 (14.5)	3.79 (20.7)
	With electromagnetic brake	2.02 (11.0)	2.59 (14.2)	3.15 (17.2)	4.29 (23.5)
Recommended load to motor inertia moment ratio		Maximum of 10 times the servo motor's inertia moment (Note 3)			
Speed/position detector		18-bit encoder (resolution: 262144 p/rev)			
Attachments		Oil seal			
Insulation class		Class F			
Structure		Totally enclosed non ventilated (IP rating: IP67) (Note 4)			
Environment (Note 6)	Ambient temperature	0 to 40°C (32 to 104°F) (non freezing), storage: -15 to 70°C (5 to 158°F) (non freezing)			
	Ambient humidity	80% RH maximum (non condensing), storage: 90% RH maximum (non condensing)			
	Atmosphere	Indoors (no direct sunlight); no corrosive gas, inflammable gas, oil mist or dust			
	Elevation	1000m or less above sea level			
Mass (kg [lb])	Standard	3.0 (6.7)	3.7 (8.2)	4.5 (10)	5.9 (13)
	With electromagnetic brake	4.4 (9.7)	5.1 (12)	5.9 (13)	7.3 (16)
With increased maximum torque: (Note 8)	Compatible servo amplifier model MR-J3-	100A4/B4(-RJ006)/T4 (Note 11)	200A4/B4(-RJ006)/T4 (Note 11)	200A4/B4(-RJ006)/T4 (Note 11)	350A4/B4(-RJ006)/T4 (Note 11)
	Maximum torque (N·m [oz·in])	6.37 (902)	9.55 (1350)	12.7 (1800)	19.1 (2700)
	Maximum current (A)	6.0	12	12	22
	Regenerative braking frequency (times/min) (Note 2)	100	489	382	275

Notes: 1. The power supply capacity varies depending on the power supply's impedance.

2. The regenerative braking frequency shows the permissible frequency when the motor, without a load and an optional regeneration unit, decelerates from the rated speed to a stop. When a load is connected; however, the value will be the table value/(m+1), where m=load inertia moment/motor inertia moment. When the operating speed exceeds the rated speed, the regenerative braking frequency is inversely proportional to the square of (operating speed/rated speed). If the operating speed changes frequently or when the regeneration is constant (as with vertical feeds), find the regenerative heating value (W) in operation. Provisions must be made to keep this heating value below the tolerable regenerative power (W). Optimal regenerative resistor varies for each system. Select the most suitable regenerative resistor by using the capacity selection software. Refer to the section "Options ● Optional regeneration unit" in this catalog for details on the tolerable regenerative power (W).

3. Contact your local sales office if the load to motor inertia moment ratio exceeds the value in the table.

4. The shaft-through portion is excluded.

HF-JP 3000r/min Series Servo Motor Torque Characteristics (400VAC Class)

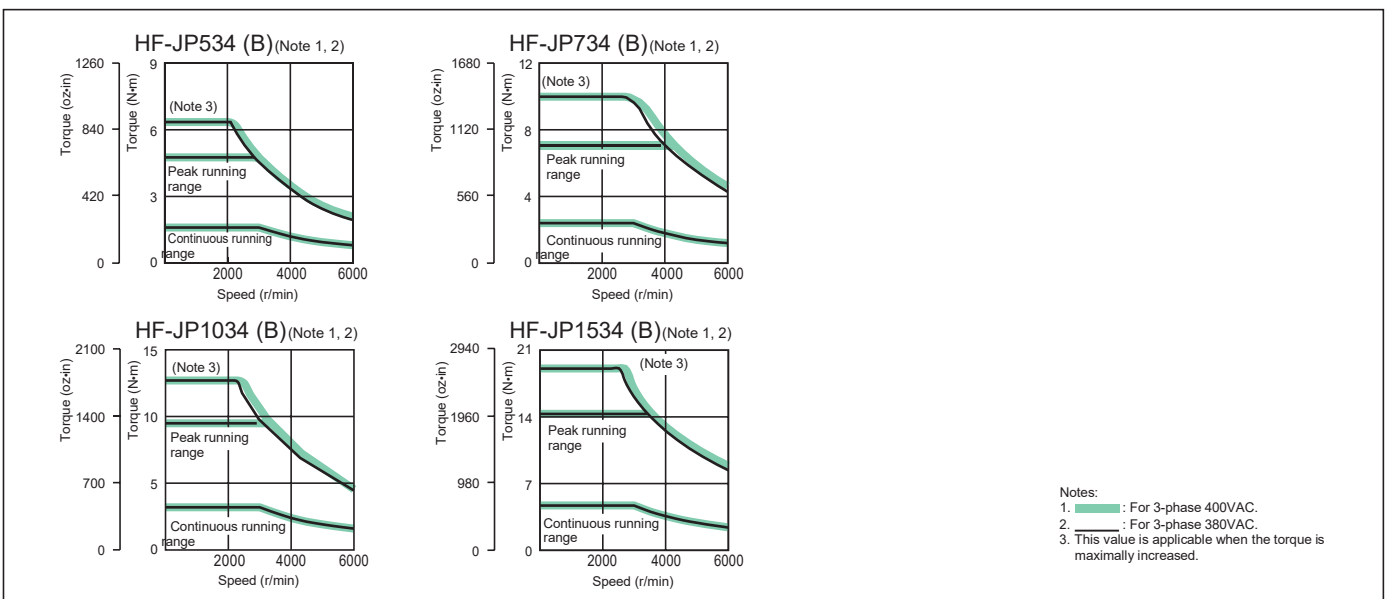

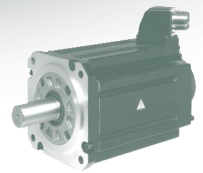

HF-JP 3000r/min series (Low inertia, medium capacity)				
2034(B)	3534(B)	5034(B)	7034(B)	9034(B)
200A4/B4(-RJ006)/T4	350A4/B4(-RJ006)/T4	500A4/B4(-RJ006)/T4	700A4/B4(-RJ006)/T4	11KA4/B4(-RJ006)/T4
3.5	5.5	7.5	10	13
2.0	3.3 <3.5> (Note 7)	5.0	7.0	9.0
6.37 (902)	10.5 (1490) <11.1 (1570)> (Note 7)	15.9 (2250)	22.3 (3160)	28.6 (4050)
19.1 (2700)	32.0 (4530)	47.7 (6750)	66.8 (9460)	85.8 (12100)
	3000			
	6000		5000	
	6900		5750	
82.4	83.5	133	115	147
5.4	8.3<8.8> (Note 7)	14	17	21
17	26	41	52	67
203	75	68	56	205 (Note 9)
4.92 (26.9)	13.2 (72.2)	19.0 (104)	43.3 (237)	55.8 (305)
5.42 (29.6)	15.4 (84.2)	21.2 (116)	52.9 (289)	65.4 (358)
Maximum of 10 times the servo motor's inertia moment (Note 3)				
18-bit encoder (resolution: 262144 p/rev)				
Oil seal				
Class F				
Totally enclosed non ventilated (IP rating: IP67) (Note 4)				
0 to 40°C (32 to 104°F) (non freezing), storage: -15 to 70°C (5 to 158°F) (non freezing)				
80% RH maximum (non condensing), storage: 90% RH maximum (non condensing)				
Indoors (no direct sunlight); no corrosive gas, inflammable gas, oil mist or dust				
1000m or less above sea level				
X: 24.5m/s ² Y: 24.5m/s ²			X: 24.5m/s ² Y: 29.4m/s ²	
7.5 (17)	13 (29)	18 (40)	29 (64)	36 (80)
8.9 (20)	15 (33)	20 (44)	35 (78)	42 (93)
350A4/B4(-RJ006)/T4 (Note 11)	500A4/B4(-RJ006)/T4 (Note 11)	700A4/B4(-RJ006)/T4 (Note 11)	-	-
25.5 (3610)	44.6 (6320)	63.7 (9020)	-	-
22	36	54	-	-
209	98	89	-	-

- The vibration direction is shown in the diagram to the right. The numeric value indicates the maximum value of the component (commonly the bracket in the opposite direction of the motor shaft). Fretting of the bearing occurs easily when the motor stops, so maintain vibration to approximately one-half of the allowable value.
- In the environment where the servo motor is exposed to oil mist, oil and/or water, a standard specification servo motor may not be usable. Contact your local sales office for more details.
- Value indicated in < > is applicable when connected to MR-J3-500A4/B4(-RJ006)/T4 servo amplifier.
- The value is applicable when the external regenerative resistors, GRZG400-M Ω (standard accessory) are used with cooling fans (2 units of 92 × 92mm, minimum air flow: 1.0m³/min). Note that change in parameter No. PA02 is required.
- The maximum torque can be increased from 300% to 400% of the rated torque by changing the servo amplifier to be combined. Refer to "Combinations for Increasing the Maximum Torque" in this catalog for more details.
- When unbalanced torque is generated, such as in a vertical lift machine, it is recommended that the unbalanced torque of the machine be kept under 70% of the motor's rated torque.
- Contact your local sales office for the unlisted servo amplifiers which enable increasing the maximum torque.

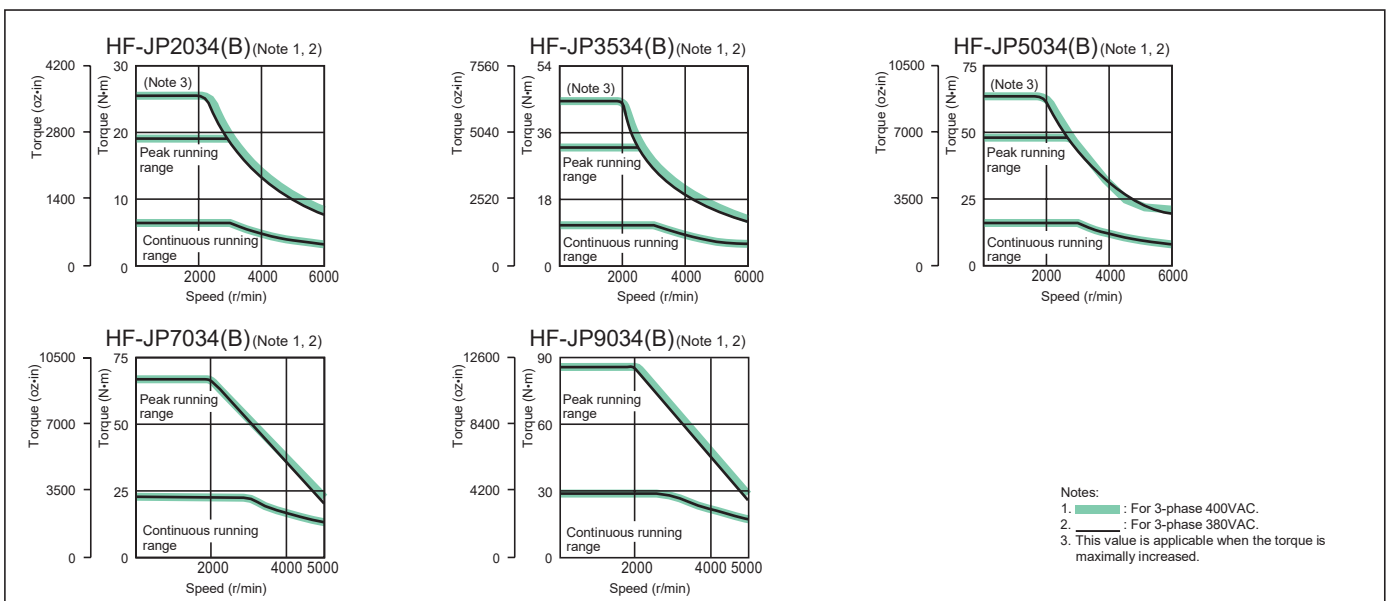

Model designation
 Servo motors
 Servo amplifiers
 Options
 Peripheral equipment
 MR-J3-B Safety series
 MR-J3W series
 Servo support software
 Cautions
 Warranty
 Global FA centers

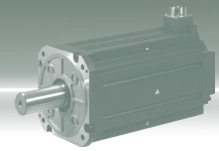

HF-JP 1500r/min Series Servo Motor Specifications (200VAC/400VAC Class)

Servo motor series		HF-JP 1500r/min series (Low inertia, large capacity) (200VAC)		HF-JP 1500r/min series (Low inertia, large capacity) (400VAC)	
Servo motor model HF-JP		11K1M(B)	15K1M(B)	11K1M4(B)	15K1M4(B)
Compatible servo amplifier model (Note 8) MR-J3-		11KA/B/T-LR (Note 10)	15KA/B/T-LR (Note 10)	11KA4/B4/T4-LR (Note 10)	15KA4/B4/T4-LR (Note 10)
Power supply capacity (Note 1) (kVA)		16	22	16	22
Continuous running duty	Rated output (kW)	11	15	11	15
	Rated torque (Note 9) (N·m [oz·in])	70 (9910)	95.5 (13500)	70 (9910)	95.5 (13500)
Maximum torque (N·m [oz·in])		210 (29700)	286 (40500)	210 (29700)	286 (40500)
Rated speed (r/min)		1500			
Maximum speed (r/min)		3000			
Permissible instantaneous speed (r/min)		3450			
Power rate at continuous rated torque (kW/s)		223	290	223	290
Rated current (A)		60	76	32	38
Maximum current (A)		200	246	100	123
Regenerative braking frequency (times/min) (Note 2, 6)		143	162	143	162
Moment of inertia J ($\times 10^{-4}$ kg·m ²) [J (oz·in ²)]	Standard	220 (1200)	315 (1720)	220 (1200)	315 (1720)
	With electromagnetic brake	240 (1310)	336 (1840)	240 (1310)	336 (1840)
Recommended load to motor inertia moment ratio		Maximum of 10 times the servo motor's inertia moment (Note 3)			
Speed/position detector		18-bit encoder (resolution: 262144 p/rev)			
Attachments		Oil seal			
Insulation class		Class F			
Structure		Totally enclosed non ventilated (IP rating: IP67) (Note 4)			
Environment (Note 7)	Ambient temperature	0 to 40°C (32 to 104°F) (non freezing), storage: -15 to 70°C (5 to 158°F) (non freezing)			
	Ambient humidity	80% RH maximum (non condensing), storage: 90% RH maximum (non condensing)			
	Atmosphere	Indoors (no direct sunlight); no corrosive gas, inflammable gas, oil mist or dust			
	Elevation	1000m or less above sea level			
	Vibration (Note 5)	X: 24.5m/s ² Y: 24.5m/s ²			
Mass (kg [lb])	Standard	62 (140)	86 (190)	62 (140)	86 (190)
	With electromagnetic brake	74 (165)	97 (215)	74 (165)	97 (215)

Notes: 1. The power supply capacity varies depending on the power supply's impedance.

2. The regenerative braking frequency shows the permissible frequency when the motor, without a load and an optional regeneration unit, decelerates from the rated speed to a stop. When a load is connected; however, the value will be the table value/(m+1), where m=load inertia moment/motor inertia moment. When the operating speed exceeds the rated speed, the regenerative braking frequency is inversely proportional to the square of (operating speed/rated speed). If the operating speed changes frequently or when the regeneration is constant (as with vertical feeds), find the regenerative heating value (W) in operation. Provisions must be made to keep this heating value below the tolerable regenerative power (W). Optimal regenerative resistor varies for each system. Select the most suitable regenerative resistor by using the capacity selection software. Refer to the section "Options" for "Optional regeneration unit" in this catalog for details on the tolerable regenerative power (W).

3. Contact your local sales office if the load to motor inertia moment ratio exceeds the value in the table.

4. The shaft-through portion is excluded.

5. The vibration direction is shown in the diagram to the right. The numeric value indicates the maximum value of the component (commonly the bracket in the opposite direction of the motor shaft). Fretting of the bearing occurs easily when the motor stops, so maintain vibration to approximately one-half of the allowable value.

6. The value is applicable when the external regenerative resistors, GRZG400-M Ω (standard accessory) are used with cooling fans (2 units of 92 \times 92mm, minimum air flow: 1.0m³/min). Note that change in parameter No. PA02 is required.

7. In the environment where the servo motor is exposed to oil mist, oil and/or water, a standard specification servo motor may not be usable. Contact your local sales office for more details.

8. Contact your local sales office for fully closed loop control compatible servo amplifier.

9. When unbalanced torque is generated, such as in a vertical lift machine, it is recommended that the unbalanced torque of the machine be kept under 70% of the motor's rated torque.

10. Use a dedicated servo amplifier MR-J3-MA(4)/B(4)/T(4)-LR-LW for HF-JP11K1M(4) and HF-JP15K1M(4). These servo motors cannot be used with any other servo amplifiers without "-LR-LW".



HF-JP 1500r/min Series Servo Motor Torque Characteristics (200VAC/400VAC Class)

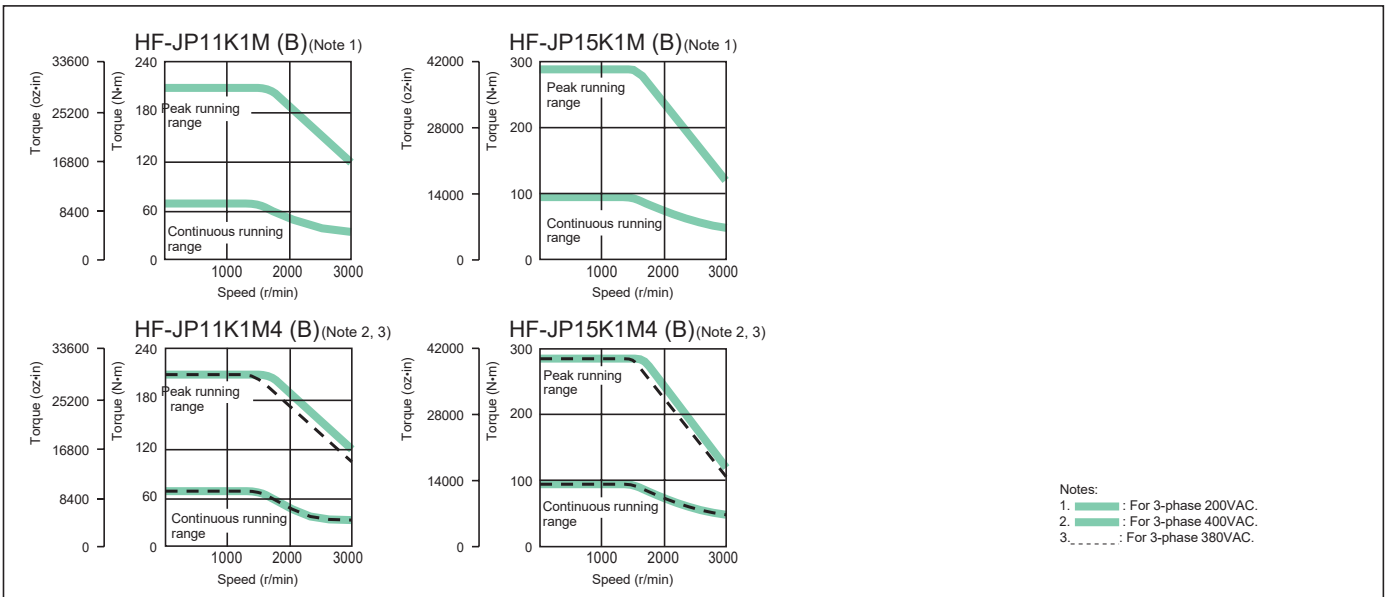

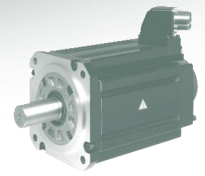

HC-LP Series Servo Motor Specifications

Servo motor series		HC-LP series (Low inertia, medium capacity)				
Servo motor model HC-LP		52(B)	102(B)	152(B)	202(B)	302(B)
Compatible servo amplifier model MR-J3-		60A/B(-RJ006)/T	100A/B(-RJ006)/T	200AN/BN(-RJ006)/TN	350A/B(-RJ006)/T	500A/B(-RJ006)/T
Power supply capacity (Note 1) (kVA)		1.0	1.7	2.5	3.5	4.8
Continuous running duty	Rated output (kW)	0.5	1.0	1.5	2.0	3.0
	Rated torque (Note 7) (N·m [oz·in])	2.39 (338)	4.78 (677)	7.16 (1010)	9.55 (1350)	14.3 (2020)
Maximum torque (N·m [oz·in])		7.16 (1010)	14.4 (2040)	21.6 (3060)	28.5 (4040)	42.9 (6070)
Rated speed (r/min)		2000				
Maximum speed (r/min)		3000				
Permissible instantaneous speed (r/min)		3450				
Power rate at continuous rated torque (kW/s)		18.4	49.3	79.8	41.5	56.8
Rated current (A)		3.2	5.9	9.9	14	23
Maximum current (A)		9.6	18	30	42	69
Regenerative braking frequency (times/min) (Note 2)		115	160	425	120	70
Moment of inertia J ($\times 10^{-4}$ kg·m ²) [J (oz·in ²)]	Standard	3.10 (16.9)	4.62 (25.3)	6.42 (35.1)	22.0 (120)	36.0 (197)
	With electromagnetic brake	5.20 (28.4)	6.72 (36.7)	8.52 (46.6)	32.0 (175)	46.0 (252)
Recommended load to motor inertia moment ratio		Maximum of 10 times the servo motor's inertia moment (Note 3)				
Speed/position detector		18-bit encoder (resolution: 262144 p/rev)				
Attachments		Oil seal				
Insulation class		Class F				
Structure		Totally enclosed non ventilated (IP rating: IP65) (Note 4)				
Environment (Note 6)	Ambient temperature	0 to 40°C (32 to 104°F) (non freezing), storage: -15 to 70°C (5 to 158°F) (non freezing)				
	Ambient humidity	80% RH maximum (non condensing), storage: 90% RH maximum (non condensing)				
	Atmosphere	Indoors (no direct sunlight); no corrosive gas, inflammable gas, oil mist or dust				
	Elevation	1000m or less above sea level				
	Vibration (Note 5)	X: 9.8m/s ² Y: 24.5m/s ²			X: 19.6m/s ² Y: 49m/s ²	
Mass (kg [lb])	Standard	6.5 (15)	8.0 (18)	10 (22)	21 (47)	28 (62)
	With electromagnetic brake	9.0 (20)	11 (25)	13 (29)	27 (60)	34 (75)

Notes: 1. The power supply capacity varies depending on the power supply's impedance.

2. The regenerative braking frequency shows the permissible frequency when the motor, without a load and an optional regeneration unit, decelerates from the rated speed to a stop. When a load is connected; however, the value will be the table value/(m+1), where m=load inertia moment/motor inertia moment. When the operating speed exceeds the rated speed, the regenerative braking frequency is inversely proportional to the square of (operating speed/rated speed). If the operating speed changes frequently or when the regeneration is constant (as with vertical feeds), find the regenerative heating value (W) in operation. Provisions must be made to keep this heating value below the tolerable regenerative power (W). Optimal regenerative resistor varies for each system. Select the most suitable regenerative resistor by using the capacity selection software. Refer to the section "Options" "Optional regeneration unit" in this catalog for details on the tolerable regenerative power (W).

3. Contact your local sales office if the load to motor inertia moment ratio exceeds the value in the table.

4. The shaft-through portion is excluded.

5. The vibration direction is shown in the diagram to the right. The numeric value indicates the maximum value of the component (commonly the bracket in the opposite direction of the motor shaft). Fretting of the bearing occurs easily when the motor stops, so maintain vibration to approximately one-half of the allowable value.

6. In the environment where the servo motor is exposed to oil mist, oil and/or water, a standard specification servo motor may not be usable. Contact your local sales office for more details.

7. When unbalanced torque is generated, such as in a vertical lift machine, it is recommended that the unbalanced torque of the machine be kept under 70% of the motor's rated torque.

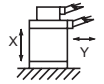

HC-LP Series Servo Motor Torque Characteristics

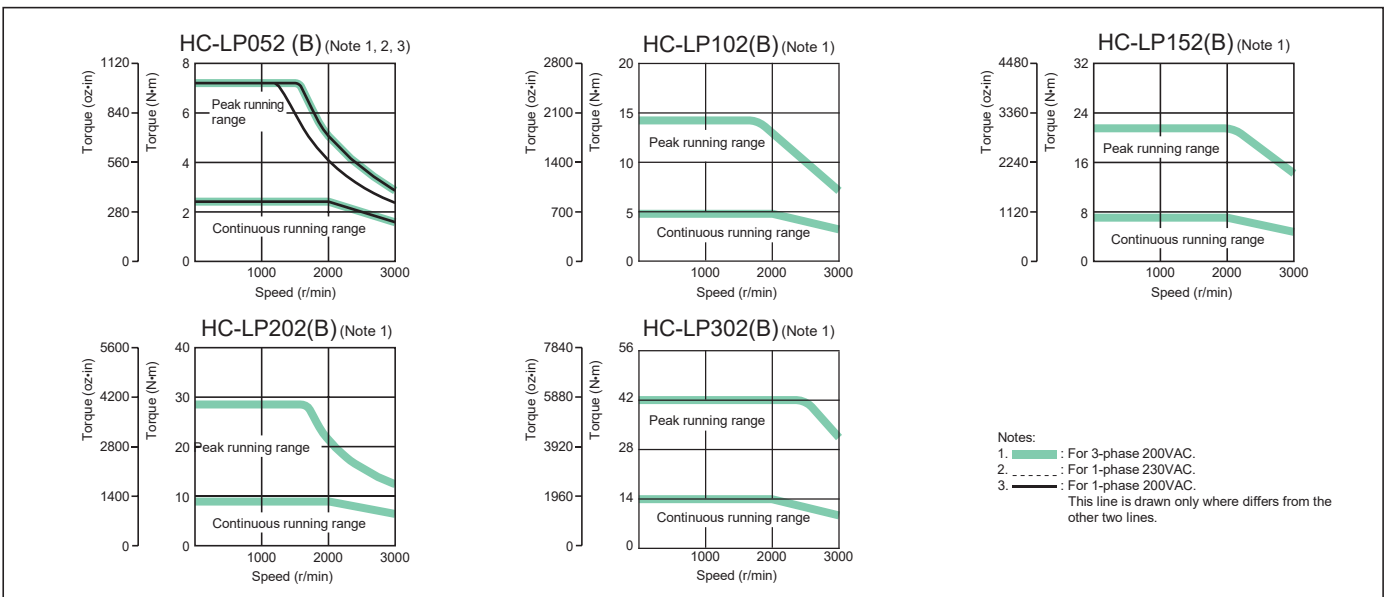

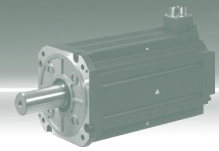

HC-RP Series Servo Motor Specifications

Servo motor series		HC-RP series (Ultra low inertia, medium capacity)				
Servo motor model HC-RP		103(B)	153(B)	203(B)	353(B)	503(B)
Compatible servo amplifier model MR-J3-		200AN/BN(-RJ006)/TN		350A/B(-RJ006)/T	500A/B(-RJ006)/T	
Power supply capacity (Note 1) (kVA)		1.7	2.5	3.5	5.5	7.5
Continuous running duty	Rated output (kW)	1.0	1.5	2.0	3.5	5.0
	Rated torque (Note 7) (N·m [oz·in])	3.18 (450)	4.78 (677)	6.37 (902)	11.1 (1570)	15.9 (2250)
Maximum torque (N·m [oz·in])		7.95 (1130)	11.9 (1690)	15.9 (2250)	27.9 (3950)	39.7 (5620)
Rated speed (r/min)		3000				
Maximum speed (r/min)		4500				
Permissible instantaneous speed (r/min)		5175				
Power rate at continuous rated torque (kW/s)		67.4	120	176	150	211
Rated current (A)		6.1	8.8	14	23	28
Maximum current (A)		18	23	37	58	70
Regenerative braking frequency (times/min) (Note 2)		1090	860	710	174	125
Moment of inertia J ($\times 10^{-4}$ kg·m ²) [J (oz·in ²)]	Standard	1.50 (8.20)	1.90 (10.4)	2.30 (12.6)	8.30 (45.4)	12.0 (65.6)
	With electromagnetic brake	1.85 (10.1)	2.25 (12.3)	2.65 (14.5)	11.8 (64.5)	15.5 (84.7)
Recommended load to motor inertia moment ratio		Maximum of 5 times the servo motor's inertia moment (Note 3)				
Speed/position detector		18-bit encoder (resolution: 262144 p/rev)				
Attachments		Oil seal				
Insulation class		Class F				
Structure		Totally enclosed non ventilated (IP rating: IP65) (Note 4)				
Environment (Note 6)	Ambient temperature	0 to 40°C (32 to 104°F) (non freezing), storage: -15 to 70°C (5 to 158°F) (non freezing)				
	Ambient humidity	80% RH maximum (non condensing), storage: 90% RH maximum (non condensing)				
	Atmosphere	Indoors (no direct sunlight); no corrosive gas, inflammable gas, oil mist or dust				
	Elevation	1000m or less above sea level				
	Vibration (Note 5)	X: 24.5m/s ² Y: 24.5m/s ²				
Mass (kg [lb])	Standard	3.9 (8.6)	5.0 (11)	6.2 (14)	12 (27)	17 (38)
	With electromagnetic brake	6.0 (14)	7.0 (16)	8.3 (19)	15 (33)	21 (47)

Notes: 1. The power supply capacity varies depending on the power supply's impedance.

2. The regenerative braking frequency shows the permissible frequency when the motor, without a load and an optional regeneration unit, decelerates from the rated speed to a stop. When a load is connected; however, the value will be the table value/(m+1), where m=load inertia moment/motor inertia moment. When the operating speed exceeds the rated speed, the regenerative braking frequency is inversely proportional to the square of (operating speed/rated speed). If the operating speed changes frequently or when the regeneration is constant (as with vertical feeds), find the regenerative heating value (W) in operation. Provisions must be made to keep this heating value below the tolerable regenerative power (W). Optimal regenerative resistor varies for each system. Select the most suitable regenerative resistor by using the capacity selection software. Refer to the section "Options" for "Optional regeneration unit" in this catalog for details on the tolerable regenerative power (W).

3. Contact your local sales office if the load to motor inertia moment ratio exceeds the value in the table.

4. The shaft-through portion is excluded.

5. The vibration direction is shown in the diagram to the right. The numeric value indicates the maximum value of the component (commonly the bracket in the opposite direction of the motor shaft). Fretting of the bearing occurs easily when the motor stops, so maintain vibration to approximately one-half of the allowable value.

6. In the environment where the servo motor is exposed to oil mist, oil and/or water, a standard specification servo motor may not be usable. Contact your local sales office for more details.

7. When unbalanced torque is generated, such as in a vertical lift machine, it is recommended that the unbalanced torque of the machine be kept under 70% of the motor's rated torque.



HC-RP Series Servo Motor Torque Characteristics

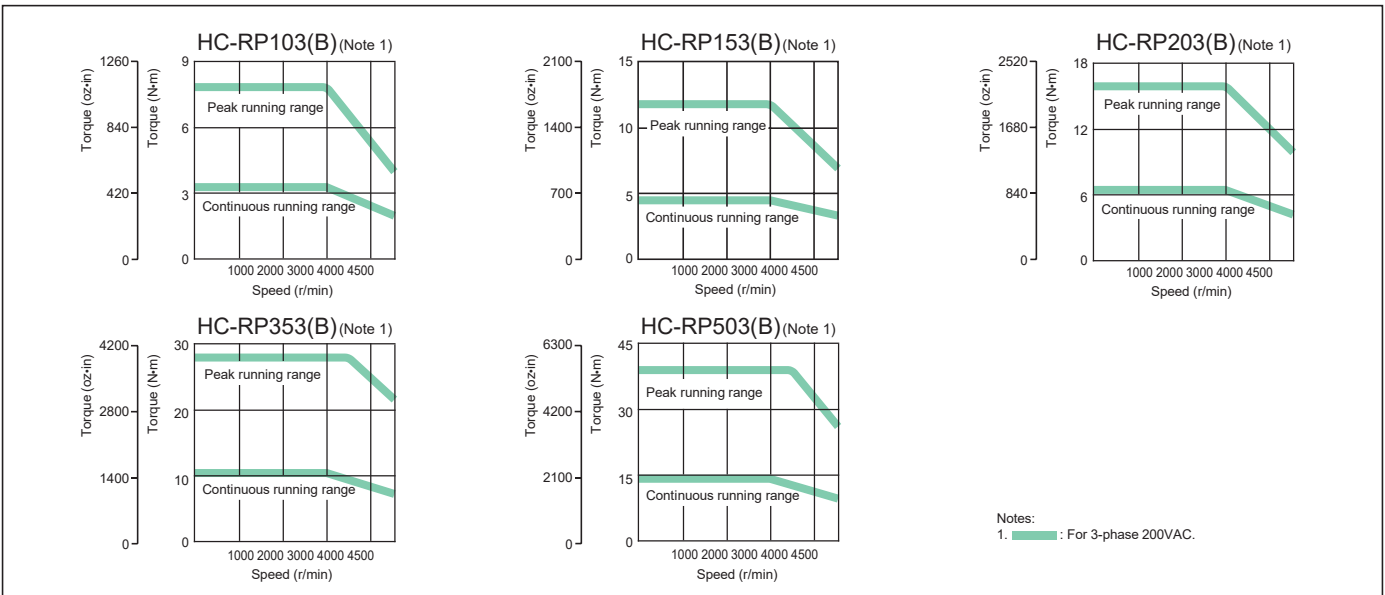

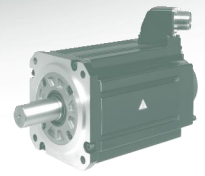

HC-UP Series Servo Motor Specifications

Servo motor series		HC-UP series (Flat type, medium capacity)				
Servo motor model HC-UP		72(B)	152(B)	202(B)	352(B)	502(B)
Compatible servo amplifier model MR-J3-		70A/B(-RJ006)/T	200AN/BN(-RJ006)/TN	350A/B(-RJ006)/T	500A/B(-RJ006)/T	
Power supply capacity (Note 1) (kVA)		1.3	2.5	3.5	5.5	7.5
Continuous running duty	Rated output (kW)	0.75	1.5	2.0	3.5	5.0
	Rated torque (Note 7) (N·m [oz·in])	3.58 (507)	7.16 (1010)	9.55 (1350)	16.7 (2360)	23.9 (3380)
Maximum torque (N·m [oz·in])		10.7 (1520)	21.6 (3060)	28.5 (4040)	50.1 (7090)	71.6 (10100)
Rated speed (r/min)		2000				
Maximum speed (r/min)		3000			2500	
Permissible instantaneous speed (r/min)		3450			2875	
Power rate at continuous rated torque (kW/s)		12.3	23.2	23.9	36.5	49.6
Rated current (A)		5.4	9.7	14	23	28
Maximum current (A)		16	29	42	69	84
Regenerative braking frequency (times/min) (Note 2)		53	124	68	44	31
Moment of inertia J ($\times 10^{-4}$ kg·m ²) [J (oz·in ²)]	Standard	10.4 (56.9)	22.1 (121)	38.2 (209)	76.5 (418)	115 (629)
	With electromagnetic brake	12.5 (68.3)	24.2 (132)	46.8 (256)	85.1 (465)	124 (678)
Recommended load to motor inertia moment ratio		Maximum of 15 times the servo motor's inertia moment (Note 3)				
Speed/position detector		18-bit encoder (resolution: 262144 p/rev)				
Attachments		Oil seal				
Insulation class		Class F				
Structure		Totally enclosed non ventilated (IP rating: IP65) (Note 4)				
Environment (Note 6)	Ambient temperature	0 to 40°C (32 to 104°F) (non freezing), storage: -15 to 70°C (5 to 158°F) (non freezing)				
	Ambient humidity	80% RH maximum (non condensing), storage: 90% RH maximum (non condensing)				
	Atmosphere	Indoors (no direct sunlight); no corrosive gas, inflammable gas, oil mist or dust				
	Elevation	1000m or less above sea level				
	Vibration (Note 5)	X: 24.5m/s ² Y: 24.5m/s ²		X: 24.5m/s ² Y: 49m/s ²		
Mass (kg [lb])	Standard	8.0 (18)	11 (25)	16 (36)	20 (44)	24 (53)
	With electromagnetic brake	10 (22)	13 (29)	22 (49)	26 (58)	30 (67)

Notes:1. The power supply capacity varies depending on the power supply's impedance.

2. The regenerative braking frequency shows the permissible frequency when the motor, without a load and an optional regeneration unit, decelerates from the rated speed to a stop. When a load is connected; however, the value will be the table value/(m+1), where m=load inertia moment/motor inertia moment. When the operating speed exceeds the rated speed, the regenerative braking frequency is inversely proportional to the square of (operating speed/rated speed). If the operating speed changes frequently or when the regeneration is constant (as with vertical feeds), find the regenerative heating value (W) in operation. Provisions must be made to keep this heating value below the tolerable regenerative power (W). Optimal regenerative resistor varies for each system. Select the most suitable regenerative resistor by using the capacity selection software. Refer to the section "Options" for "Optional regeneration unit" in this catalog for details on the tolerable regenerative power (W).

3. Contact your local sales office if the load to motor inertia moment ratio exceeds the value in the table.

4. The shaft-through portion is excluded.

5. The vibration direction is shown in the diagram to the right. The numeric value indicates the maximum value of the component (commonly the bracket in the opposite direction of the motor shaft). Fretting of the bearing occurs easily when the motor stops, so maintain vibration to approximately one-half of the allowable value.

6. In the environment where the servo motor is exposed to oil mist, oil and/or water, a standard specification servo motor may not be usable. Contact your local sales office for more details.

7. When unbalanced torque is generated, such as in a vertical lift machine, it is recommended that the unbalanced torque of the machine be kept under 70% of the motor's rated torque.

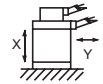

HC-UP Series Servo Motor Torque Characteristics

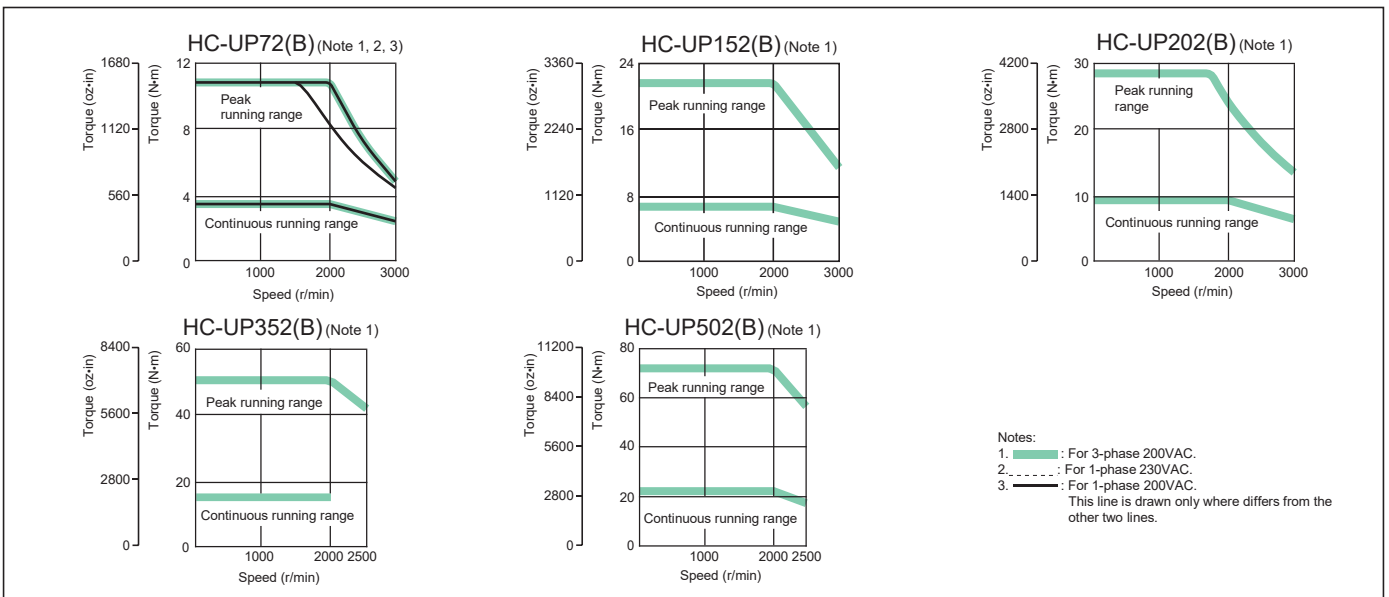

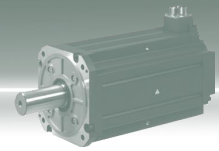

HA-LP 1000r/min Series Servo Motor Specifications (200VAC Class)

Servo motor series		HA-LP 1000r/min series (Low inertia, medium/large capacity)								
Servo motor model HA-LP		601(B)	801(B)	12K1(B)	15K1	20K1	25K1	30K1	37K1	
Compatible servo amplifier model MR-J3-		700A/B (-RJ006)/T	11KA/B(-RJ006)/T		15KA/B (-RJ006)/T	22KA/B(-RJ006)/T		DU30KA/B	DU37KA/B	
Power supply capacity (Note 1) (kVA)		8.6	12	18	22	30	38	48	59	
Continuous running duty	Rated output (kW)	6.0	8.0	12	15	20	25	30	37	
	Rated torque (Note 8)(N·m [oz·in])	57.3 (8110)	76.4 (10800)	115 (16300)	143 (20200)	191 (27000)	239 (33800)	286 (40500)	353 (50000)	
Maximum torque (N·m [oz·in])		172 (24400)	229 (32400)	344 (48700)	415 (58800)	477 (67500)	597 (84500)	716 (101000)	883 (125000)	
Rated speed (r/min)		1000								
Maximum speed (r/min)		1200								
Permissible instantaneous speed (r/min)		1380								
Power rate at continuous rated torque (kW/s)		313	265	445	373	561	528	626	668	
Rated current (A)		34	42	61	83	118	118	154	188	
Maximum current (A)		102	126	183	249	295	295	385	470	
Regenerative braking frequency (times/min) (Note 2)		158	354 (Note 6)	264 (Note 6)	230 (Note 6)	195 (Note 6)	117 (Note 6)	-	-	
Moment of inertia J ($\times 10^{-4}$ kg·m ²) [J (oz·in ²)]	Standard	105 (574)	220 (1200)	295 (1610)	550 (3010)	650 (3550)	1080 (5900)	1310 (7160)	1870 (10200)	
	With electromagnetic brake	113 (618)	293 (1600)	369 (2020)	-	-	-	-	-	
Recommended load to motor inertia moment ratio		Maximum of 10 times the servo motor's inertia moment (Note 3)								
Speed/position detector		18-bit encoder (resolution: 262144 p/rev)								
Attachments		Oil seal								
Insulation class		Class F								
Structure		Totally enclosed ventilated (IP rating: IP44) (Note 4)								
Environment (Note 7)	Ambient temperature	0 to 40°C (32 to 104°F) (non freezing), storage: -15 to 70°C (5 to 158°F) (non freezing)								
	Ambient humidity	80% RH maximum (non condensing), storage: 90% RH maximum (non condensing)								
	Atmosphere	Indoors (no direct sunlight); no corrosive gas, inflammable gas, oil mist or dust								
	Elevation	1000m or less above sea level								
Mass (kg [lb])	Standard	55 (125)	95 (210)	115 (255)	160 (355)	180 (400)	230 (510)	250 (555)	335 (740)	
	With electromagnetic brake	70 (155)	130 (290)	150 (335)	-	-	-	-	-	
Cooling fan	Power	Voltage, frequency	3-phase 200 to 230VAC 50/60Hz 1-phase 200 to 220VAC/60Hz 1-phase 200 to 230VAC/60Hz							
		Input (W)	42(50Hz)/54(60Hz)	62 (50Hz) / 76 (60Hz)	65 (50Hz) / 85 (60Hz)	120 (50Hz) / 175 (60Hz)				
	Rated current (A)	0.21 (50Hz) / 0.25 (60Hz)	0.18 (50Hz) / 0.17 (60Hz)	0.20 (50Hz) / 0.22 (60Hz)	0.65 (50Hz) / 0.80 (60Hz)					

Notes:1. The power supply capacity varies depending on the power supply's impedance.

2. The regenerative braking frequency shows the permissible frequency when the motor, without a load and an optional regeneration unit, decelerates from the rated speed to a stop. When a load is connected; however, the value will be the table value/(m+1), where m=load inertia moment/motor inertia moment. When the operating speed exceeds the rated speed, the regenerative braking frequency is inversely proportional to the square of (operating speed/rated speed). If the operating speed changes frequently or when the regeneration is constant (as with vertical feeds), find the regenerative heating value (W) in operation. Provisions must be made to keep this heating value below the tolerable regenerative power (W). Optimal regenerative resistor varies for each system. Select the most suitable regenerative resistor by using the capacity selection software. Refer to the section "Options ● Optional regeneration unit" in this catalog for details on the tolerable regenerative power (W).

HA-LP 1000r/min Series Servo Motor Torque Characteristics (200VAC Class)

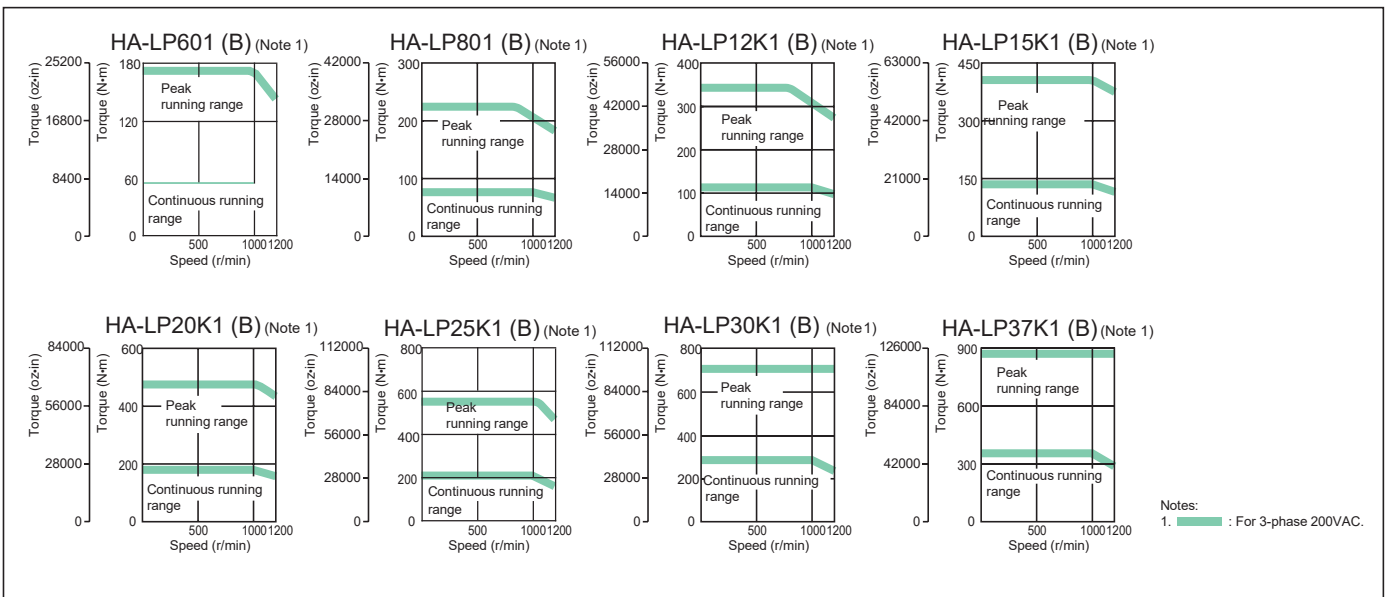

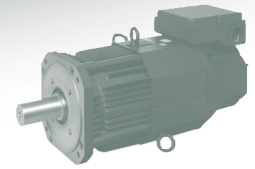

HA-LP 1000r/min Series Servo Motor Specifications (400VAC Class)

HA-LP 1000r/min series (Low inertia, medium/large capacity)							
6014(B)	8014(B)	12K14(B)	15K14	20K14	25K14	30K14	37K14
700A4/B4 (-RJ006)/T4	11KA4/B4(-RJ006)/T4		15KA4/B4 (-RJ006)/T4	22KA4/B4 (-RJ006)/T4	DU30KA4/B4		DU37KA4/B4
8.6	12	18	22	30	38	48	59
6.0	8.0	12	15	20	25	30	37
57.3 (8110)	76.4 (10800)	115 (16300)	143 (20200)	191 (27000)	239 (33800)	286 (40500)	353 (50000)
172 (24400)	229 (32400)	344 (48700)	415 (58800)	477 (67500)	597 (84500)	716 (101000)	883 (125000)
1000							
1200							
1380							
313	265	445	373	561	528	626	668
17	20	30	40	55	70	77	95
51	60	90	120	138	175	193	238
169	354 (Note 6)	264 (Note 6)	230 (Note 6)	195 (Note 6)	-	-	-
105 (574)	220 (1200)	295 (1610)	550 (3010)	650 (3550)	1080 (5900)	1310 (7160)	1870 (10200)
113 (618)	293 (1600)	369 (2020)	-	-	-	-	-
Maximum of 10 times the servo motor's inertia moment (Note 3)							
18-bit encoder (resolution: 262144 p/rev)							
Oil seal							
Class F							
Totally enclosed ventilated (IP rating: IP44) (Note 4)							
0 to 40°C (32 to 104°F) (non freezing), storage: -15 to 70°C (5 to 158°F) (non freezing)							
80% RH maximum (non condensing), storage: 90% RH maximum (non condensing)							
Indoors (no direct sunlight); no corrosive gas, inflammable gas, oil mist or dust							
1000m or less above sea level							
X: 11.7m/s ² Y: 29.4m/s ²				X: 9.8m/s ² Y: 9.8m/s ²			
55 (125)	95 (210)	115 (255)	160 (355)	180 (400)	230 (510)	250 (555)	335 (740)
70 (155)	130 (290)	150 (335)	-	-	-	-	-
1-phase 200 to 220VAC/50Hz 1-phase 200 to 230VAC/60Hz	3-phase 380 to 440VAC/50Hz 3-phase 380 to 480VAC/60Hz		3-phase 380 to 460VAC/50Hz 3-phase 380 to 480VAC/60Hz				
42(50Hz)/54(60Hz)	62(50Hz) / 76(60Hz)		65(50Hz) / 85(60Hz)		110(50Hz) / 150(60Hz)		
0.21(50Hz)/0.25(60Hz)	0.14(50Hz) / 0.11(60Hz)		0.12(50Hz) / 0.14(60Hz)		0.20(50Hz) / 0.22(60Hz)		

3. Contact your local sales office if the load to motor inertia moment ratio exceeds the value in the table.

4. The shaft-through portion is excluded.

5. The vibration direction is shown in the diagram to the right. The numeric value indicates the maximum value of the component (commonly the bracket in the opposite x direction of the motor shaft). Fretting of the bearing occurs easily when the motor stops, so maintain vibration to approximately one-half of the allowable value.

6. The value is applicable when the external regenerative resistors, GRZG400-M Ω (standard accessory) are used with cooling fans (2 units of 92 × 92mm, minimum air flow: 1.0m³/min). Note that change in parameter No. PA02 is required.

7. In the environment where the servo motor is exposed to oil mist, oil and/or water, a standard specification servo motor may not be usable. Contact your local sales office for more details.

8. When unbalanced torque is generated, such as in a vertical lift machine, it is recommended that the unbalanced torque of the machine be kept under 70% of the motor's rated torque.



HA-LP 1000r/min Series Servo Motor Torque Characteristics (400VAC Class)

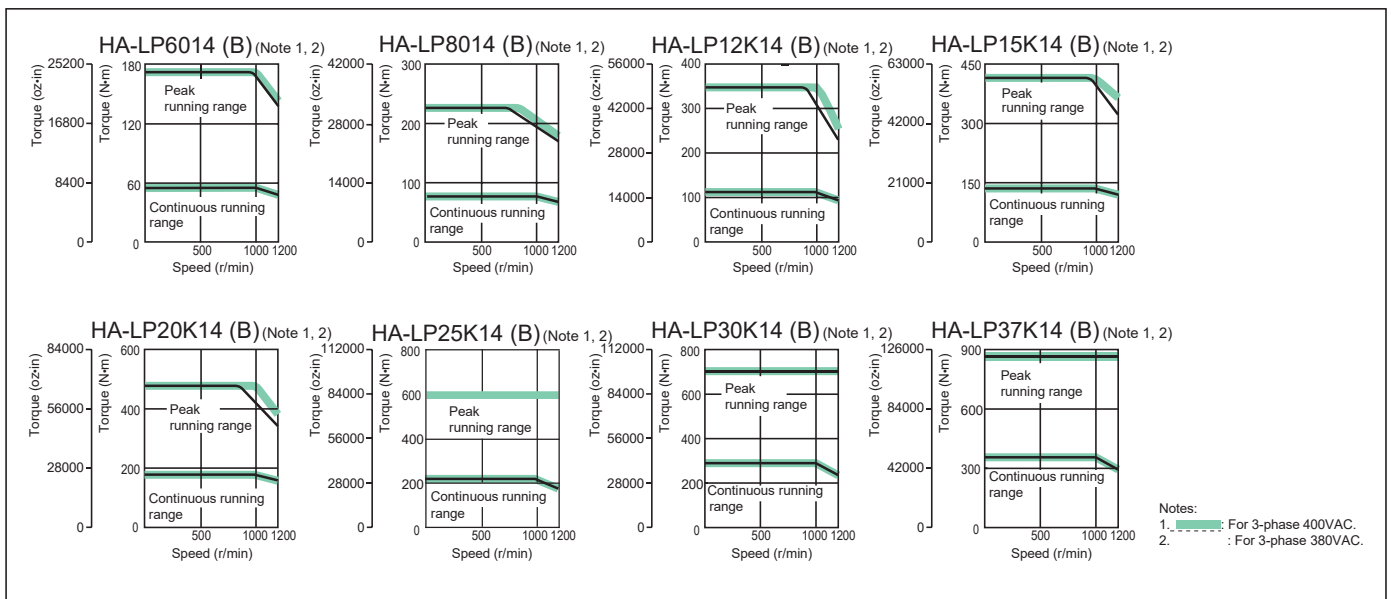

Model designation
Servo motors
Servo amplifiers
Options
Peripheral equipment
MR-J3-B Safety
MR-J3W series
Servo support software
Cautions
Warranty
Global FA centers

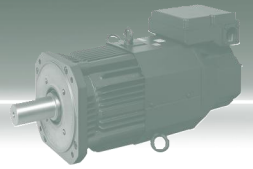

HA-LP 1500r/min Series Servo Motor Specifications (200VAC Class)

Servo motor series		HA-LP 1500r/min series (Low inertia, medium/large capacity)					
Servo motor model HA-LP		701M(B)	11K1M(B)	15K1M(B)	22K1M	30K1M	37K1M
Compatible servo amplifier model MR-J3-		700A/B(-RJ006)/T	11KA/B(-RJ006)/T	15KA/B(-RJ006)/T	22KA/B(-RJ006)/T	DU30KA/B	DU37KA/B
Power supply capacity (Note 1) (kVA)		10	16	22	33	48	59
Continuous running duty	Rated output (kW)	7.0	11	15	22	30	37
	Rated torque (Note 8) (N·m [oz·in])	44.6 (6320)	70.0 (9910)	95.5 (13500)	140 (19800)	191 (27000)	236 (33400)
Maximum torque (N·m [oz·in])		134 (19000)	210 (29700)	286 (40500)	350 (49600)	477 (67500)	589 (83400)
Rated speed (r/min)		1500					
Maximum speed (r/min)		2000					
Permissible instantaneous speed (r/min)		2300					
Power rate at continuous rated torque (kW/s)		189	223	309	357	561	514
Rated current (A)		37	65	87	126	174	202
Maximum current (A)		111	195	261	315	435	505
Regenerative braking frequency (times/min) (Note 2)		70	158 (Note 6)	191 (Note 6)	102 (Note 6)	—	—
Moment of inertia J ($\times 10^{-4}$ kg·m ²) [J (oz·in ²)]	Standard	105 (574)	220 (1200)	295 (1610)	550 (3010)	650 (3550)	1080 (5900)
	With electromagnetic brake	113 (618)	293 (1600)	369 (2020)	—	—	—
Recommended load to motor inertia moment ratio		Maximum of 10 times the servo motor's inertia moment (Note 3)					
Speed/position detector		18-bit encoder (resolution: 262144 p/rev)					
Attachments		Oil seal					
Insulation class		Class F					
Structure		Totally enclosed ventilated (IP rating: IP44) (Note 4)					
Environment (Note 7)	Ambient temperature	0 to 40°C (32 to 104°F) (non freezing), storage: -15 to 70°C (5 to 158°F) (non freezing)					
	Ambient humidity	80% RH maximum (non condensing), storage: 90% RH maximum (non condensing)					
	Atmosphere	Indoors (no direct sunlight); no corrosive gas, inflammable gas, oil mist or dust					
	Elevation	1000m or less above sea level					
	Vibration (Note 5)	X: 11.7m/s ² Y: 29.4m/s ²			X: 9.8m/s ² Y: 9.8m/s ²		
Mass (kg [lb])	Standard	55 (125)	95 (210)	115 (255)	160 (355)	180 (400)	230 (510)
	With electromagnetic brake	70 (155)	130 (290)	150 (335)	—	—	—
Cooling fan	Power	Voltage, frequency	1-phase 200 to 220VAC/50Hz 1-phase 200 to 230VAC/60Hz 3-phase 200 to 230VAC 50/60Hz				
		Input (W)	42 (50Hz)/54 (60Hz)		62 (50Hz) / 76 (60Hz)		65 (50Hz) / 85 (60Hz) 120(50Hz)/175(60Hz)
	Rated current (A)	0.21(50Hz)/0.25(60Hz)		0.18 (50Hz) / 0.17 (60Hz)		0.20 (50Hz) / 0.22 (60Hz) 0.65(50Hz)/0.80(60Hz)	

Notes:1. The power supply capacity varies depending on the power supply's impedance.

2. The regenerative braking frequency shows the permissible frequency when the motor, without a load and an optional regeneration unit, decelerates from the rated speed to a stop. When a load is connected; however, the value will be the table value/(m+1), where m=load inertia moment/motor inertia moment. When the operating speed exceeds the rated speed, the regenerative braking frequency is inversely proportional to the square of (operating speed/rated speed). If the operating speed changes frequently or when the regeneration is constant (as with vertical feeds), find the regenerative heating value (W) in operation. Provisions must be made to keep this heating value below the tolerable regenerative power (W). Optional regenerative resistor varies for each system. Select the most suitable regenerative resistor by using the capacity selection software. Refer to the section "Options ● Optional regeneration unit" in this catalog for details on the tolerable regenerative power (W).

HA-LP 1500r/min Series Servo Motor Torque Characteristics (200VAC Class)

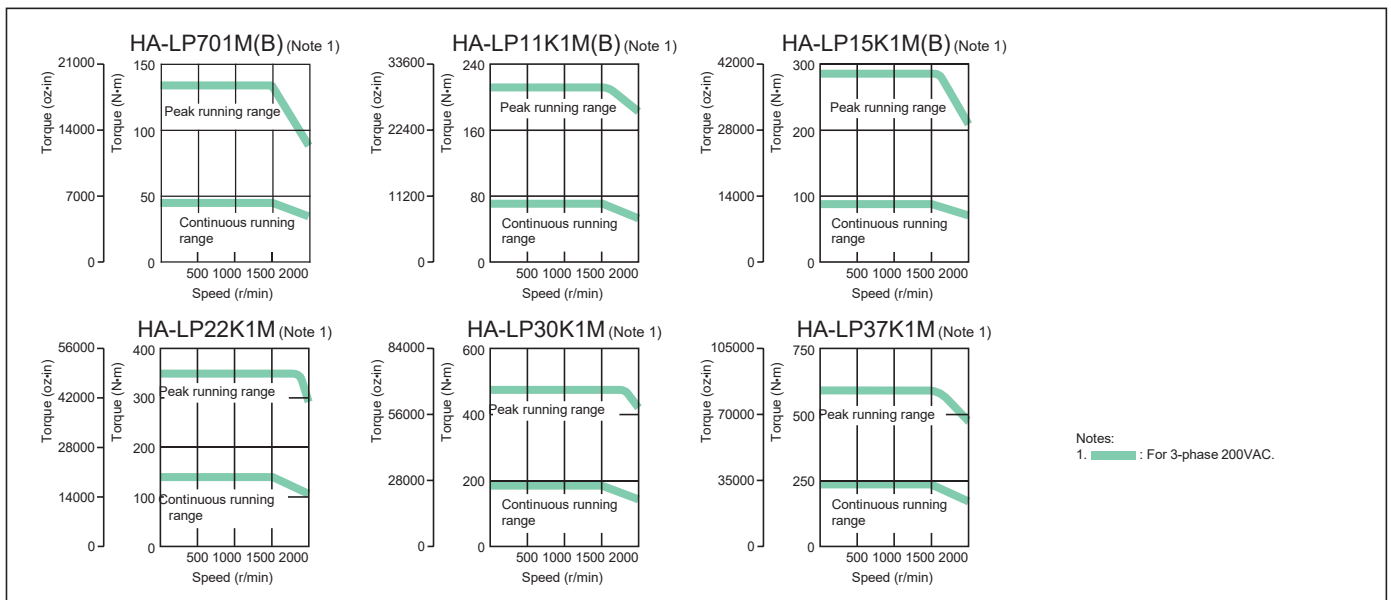

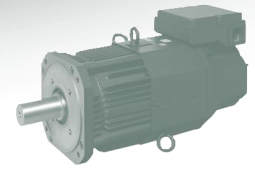

HA-LP 1500r/min Series Servo Motor Specifications (400VAC Class)

HA-LP 1500r/min series (Low inertia, medium/large capacity)								
701M4(B)	11K1M4(B)	15K1M4(B)	22K1M4	30K1M4	37K1M4	45K1M4	50K1M4	
700A4/B4(-RJ006)/T4	11KA4/B4(-RJ006)/T4	15KA4/B4(-RJ006)/T4	22KA4/B4(-RJ006)/T4	DU30KA4/B4	DU37KA4/B4	DU45KA4/B4	DU55KA4/B4	
10	16	22	33	48	59	71	80	
7.0	11	15	22	30	37	45	50	
44.6 (6320)	70.0 (9910)	95.5 (13500)	140 (19800)	191 (27000)	236 (33400)	286 (40500)	318 (45000)	
134 (19000)	210 (29700)	286 (40500)	350 (49600)	477 (67500)	589 (83400)	716 (101000)	796 (113000)	
1500								
2000								
2300								
189	223	309	357	561	514	626	542	
18	31	41	63	87	101	128	143	
54	93	123	158	218	253	320	358	
75	158 (Note 6)	191 (Note 6)	102 (Note 6)	—	—	—	—	
105 (574)	220 (1200)	295 (1610)	550 (3010)	650 (3550)	1080 (5900)	1310 (7160)	1870 (10200)	
113 (618)	293 (1600)	369 (2020)	—	—	—	—	—	
Maximum of 10 times the servo motor's inertia moment (Note 3)								
18-bit encoder (resolution: 262144 p/rev)								
Oil seal								
Class F								
Totally enclosed ventilated (IP rating: IP44) (Note 4)								
0 to 40°C (32 to 104°F) (non freezing), storage: -15 to 70°C (5 to 158°F) (non freezing)								
80% RH maximum (non condensing), storage: 90% RH maximum (non condensing)								
Indoors (no direct sunlight); no corrosive gas, inflammable gas, oil mist or dust								
1000m or less above sea level								
X: 11.7m/s ² Y: 29.4m/s ²				X: 9.8m/s ² Y: 9.8m/s ²				
55 (125)	95 (210)	115 (255)	160 (355)	180 (400)	230 (510)	250 (555)	335 (740)	
70 (155)	130 (290)	150 (335)	—	—	—	—	—	
1-phase 200 to 220VAC/50Hz 1-phase 200 to 230VAC/60Hz	3-phase 380 to 440VAC/50Hz 3-phase 380 to 480VAC/60Hz	3-phase 380 to 460VAC/50Hz 3-phase 380 to 480VAC/60Hz						
42 (50Hz) / 54 (60Hz)	62 (50Hz) / 76 (60Hz)	65 (50Hz) / 85 (60Hz)			110 (50Hz) / 150 (60Hz)			
0.21 (50Hz) / 0.25 (60Hz)	0.14 (50Hz) / 0.11 (60Hz)	0.12 (50Hz) / 0.14 (60Hz)			0.20 (50Hz) / 0.22 (60Hz)			

- Contact your local sales office if the load to motor inertia moment ratio exceeds the value in the table.
- The shaft-through portion is excluded.
- The vibration direction is shown in the diagram to the right. The numeric value indicates the maximum value of the component (commonly the bracket in the opposite x direction of the motor shaft). Fretting of the bearing occurs easily when the motor stops, so maintain vibration to approximately one-half of the allowable value.
- The value is applicable when the external regenerative resistors, GRZG400-M Ω (standard accessory) are used with cooling fans (2 units of 92 x 92mm, minimum air flow: 1.0m³/min). Note that change in parameter No. PA02 is required.
- In the environment where the servo motor is exposed to oil mist, oil and/or water, a standard specification servo motor may not be usable. Contact your local sales office for more details.
- When unbalanced torque is generated, such as in a vertical lift machine, it is recommended that the unbalanced torque of the machine be kept under 70% of the motor's rated torque.



HA-LP 1500r/min Series Servo Motor Torque Characteristics (400VAC Class)

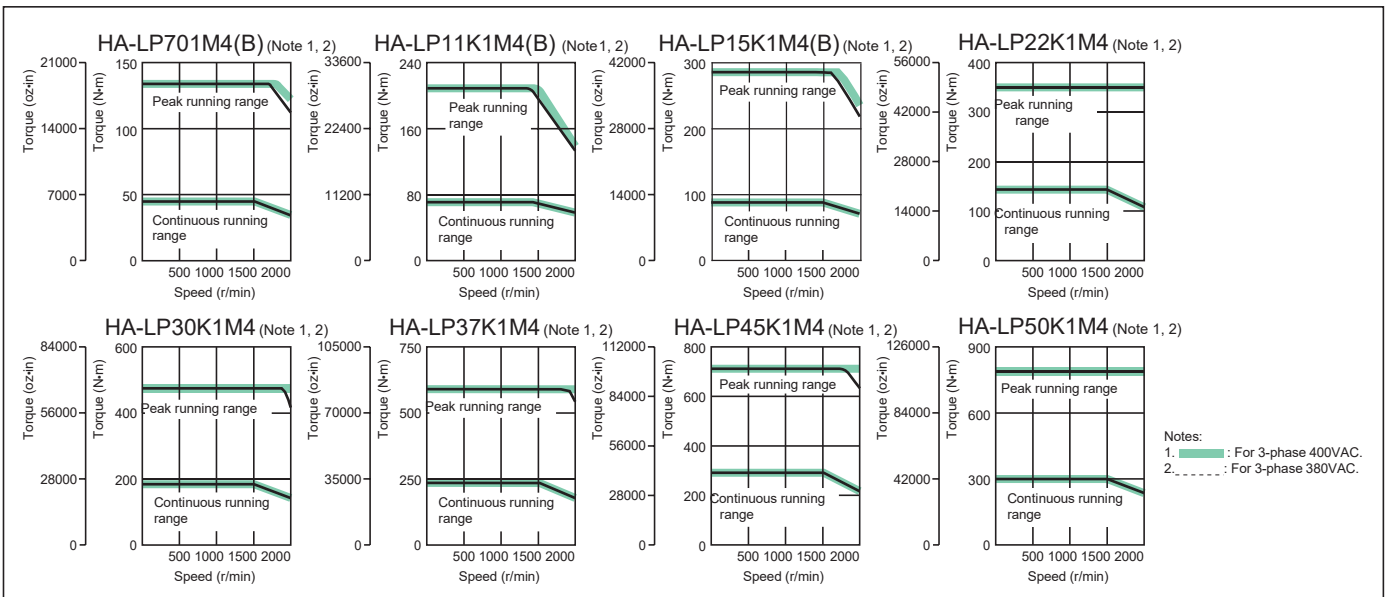

Model designation
 Servo motors
 Servo amplifiers
 Options
 Peripheral equipment
 MR-J3-B Safety
 MR-J3W series
 Servo support software
 Cautions
 Warranty
 Global FA centers

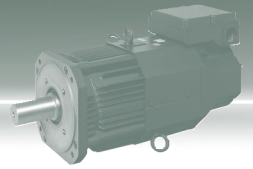

HA-LP 2000r/min Series Servo Motor Specifications (200VAC Class)

Servo motor series		HA-LP 2000r/min series (Low inertia, medium/large capacity)						
Servo motor model HA-LP		502	702	11K2(B)	15K2(B)	22K2(B)	30K2	37K2
Compatible servo amplifier model MR-J3-		500A/B(-RJ006)/T	700A/B(-RJ006)/T	11KA/B(-RJ006)/T	15KA/B(-RJ006)/T	22KA/B(-RJ006)/T	DU30KA/B	DU37KA/B
Power supply capacity (Note 1) (kVA)		7.5	10	16	22	33	48	59
Continuous running duty	Rated output (kW)	5.0	7.0	11	15	22	30	37
	Rated torque (Note 8) (N·m [oz·in])	23.9 (3380)	33.4 (4730)	52.5 (7430)	71.6 (10100)	105 (14900)	143 (20200)	177 (25100)
Maximum torque (N·m [oz·in])		71.6 (10100)	100 (14200)	158 (22400)	215 (30400)	263 (37200)	358 (50700)	442 (62600)
Rated speed (r/min)		2000						
Maximum speed (r/min)		2000						
Permissible instantaneous speed (r/min)		2300						
Power rate at continuous rated torque (kW/s)		77.2	118	263	233	374	373	480
Rated current (A)		25	34	63	77	112	166	204
Maximum current (A)		75	102	189	231	280	415	510
Regenerative braking frequency (times/min) (Note 2)		50	50	186 (Note 6)	144 (Note 6)	107 (Note 6)	—	—
Moment of inertia J ($\times 10^{-4}$ kg·m ²) [J (oz·in ²)]	Standard	74.0 (405)	94.2 (515)	105 (574)	220 (1200)	295 (1610)	550 (3010)	650 (3550)
	With electromagnetic brake	—	—	113 (618)	293 (1600)	369 (2020)	—	—
Recommended load to motor inertia moment ratio		Maximum of 10 times the servo motor's inertia moment (Note 3)						
Speed/position detector		18-bit encoder (resolution: 262144 p/rev)						
Attachments		Oil seal						
Insulation class		Class F						
Structure		Totally enclosed non ventilated (IP rating: IP65) (Note 4)			Totally enclosed ventilated (IP rating: IP44) (Note 4)			
Environment (Note 7)	Ambient temperature	0 to 40°C (32 to 104°F) (non freezing), storage: -15 to 70°C (5 to 158°F) (non freezing)						
	Ambient humidity	80% RH maximum (non condensing), storage: 90% RH maximum (non condensing)						
	Atmosphere	Indoors (no direct sunlight); no corrosive gas, inflammable gas, oil mist or dust						
	Elevation	1000m or less above sea level						
	Vibration (Note 5)	X: 11.7m/s ² Y: 29.4m/s ²					X: 9.8m/s ² Y: 9.8m/s ²	
Mass (kg [lb])	Standard	28 (62)	35 (78)	55 (125)	95 (210)	115 (255)	160 (355)	180 (400)
	With electromagnetic brake	—	—	70 (155)	130 (290)	150 (335)	—	—
Cooling fan	Power	Voltage, frequency	—		1-phase 200 to 220VAC/50Hz 1-phase 200 to 230VAC/60Hz		3-phase 200 to 230VAC 50/60Hz	
		Input (W)	—		42 (50Hz) / 54 (60Hz)		62 (50Hz) / 76 (60Hz) / 65 (50Hz) / 85 (60Hz)	
	Rated current (A)	—		0.21 (50Hz) / 0.25 (60Hz)		0.18 (50Hz) / 0.17 (60Hz)		0.20 (50Hz) / 0.22 (60Hz)

Notes: 1. The power supply capacity varies depending on the power supply's impedance.

2. The regenerative braking frequency shows the permissible frequency when the motor, without a load and an optional regeneration unit, decelerates from the rated speed to a stop. When a load is connected; however, the value will be the table value/(m+1), where m=load inertia moment/motor inertia moment. When the operating speed exceeds the rated speed, the regenerative braking frequency is inversely proportional to the square of (operating speed/rated speed). If the operating speed changes frequently or when the regeneration is constant (as with vertical feeds), find the regenerative heating value (W) in operation. Provisions must be made to keep this heating value below the tolerable regenerative power (W). Optimal regenerative resistor varies for each system. Select the most suitable regenerative resistor by using the capacity selection software. Refer to the section "Options ● Optional regeneration unit" in this catalog for details on the tolerable regenerative power (W).

HA-LP 2000r/min Series Servo Motor Torque Characteristics (200VAC Class)

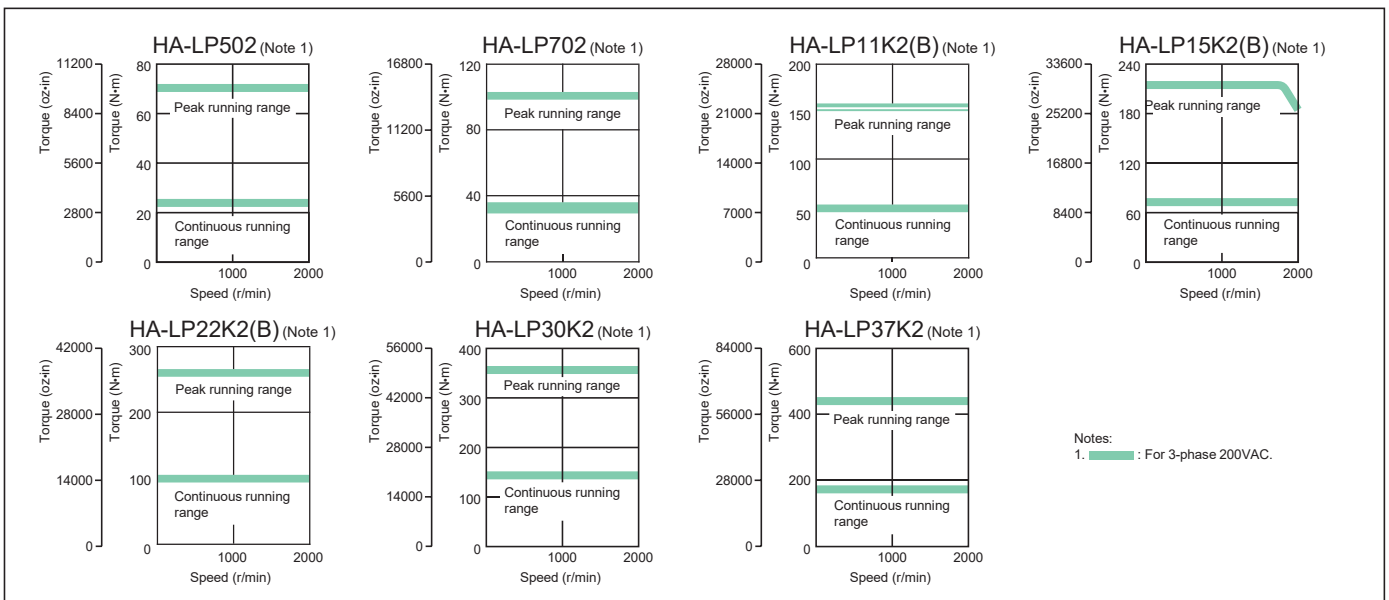

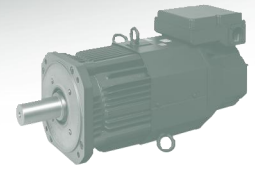

HA-LP 2000r/min Series Servo Motor Specifications (400VAC Class)

HA-LP 2000r/min series (Low inertia, medium/large capacity)							
11K24(B)	15K24(B)	22K24(B)	30K24	37K24	45K24	55K24	
11KA4/B4(-RJ006)/T4	15KA4/B4(-RJ006)/T4	22KA4/B4(-RJ006)/T4	DU30KA4/B4	DU37KA4/B4	DU45KA4/B4	DU55KA4/B4	
16	22	33	48	59	71	87	
11	15	22	30	37	45	55	
52.5 (7430)	71.6 (10100)	105 (14900)	143 (20200)	177 (25100)	215 (30400)	263 (37200)	
158 (22400)	215 (30400)	263 (37200)	358 (50700)	442 (62600)	537 (76000)	657 (93000)	
2000							
2000							
2300							
263	233	374	373	480	427	526	
32	40	57	83	102	131	143	
96	120	143	208	255	328	358	
186 (Note 6)	144 (Note 6)	107 (Note 6)	—	—	—	—	
105 (574)	220 (1200)	295 (1610)	550 (3010)	650 (3550)	1080 (5900)	1310 (7160)	
113 (618)	293 (1600)	369 (2020)	—	—	—	—	
Maximum of 10 times the servo motor's inertia moment (Note 3)							
18-bit encoder (resolution: 262144 p/rev)							
Oil seal							
Class F							
Totally enclosed ventilated (IP rating: IP44) (Note 4)							
0 to 40°C (32 to 104°F) (non freezing), storage: -15 to 70°C (5 to 158°F) (non freezing)							
80% RH maximum (non condensing), storage: 90% RH maximum (non condensing)							
Indoors (no direct sunlight); no corrosive gas, inflammable gas, oil mist or dust							
1000m or less above sea level							
X: 11.7m/s ² Y: 29.4m/s ²			X: 9.8m/s ² Y: 9.8m/s ²				
55 (125)	95 (210)	115 (255)	160 (355)	180 (400)	230 (510)	250 (555)	
70 (155)	130 (290)	150 (335)	—	—	—	—	
1-phase 200 to 220VAC/50Hz 1-phase 200 to 230VAC/60Hz	3-phase 380 to 440VAC/50Hz 3-phase 380 to 480VAC/60Hz		3-phase 380 to 460VAC/50Hz 3-phase 380 to 480VAC/60Hz				
42 (50Hz) / 54 (60Hz)	62 (50Hz) / 76 (60Hz)		65 (50Hz) / 85 (60Hz)		110 (50Hz) / 150 (60Hz)		
0.21 (50Hz)/0.25 (60Hz)	0.14 (50Hz) / 0.11 (60Hz)		0.12 (50Hz) / 0.14 (60Hz)		0.20 (50Hz) / 0.22 (60Hz)		

3. Contact your local sales office if the load to motor inertia moment ratio exceeds the value in the table.

4. The shaft-through portion is excluded.

5. The vibration direction is shown in the diagram to the right. The numeric value indicates the maximum value of the component (commonly the bracket in the opposite x direction of the motor shaft). Fretting of the bearing occurs easily when the motor stops, so maintain vibration to approximately one-half of the allowable value.

6. The value is applicable when the external regenerative resistors, GRZG400-M Ω (standard accessory) are used with cooling fans (2 units of 92 x 92mm, minimum air flow: 1.0m³/min). Note that change in parameter No. PA02 is required.

7. In the environment where the servo motor is exposed to oil mist, oil and/or water, a standard specification servo motor may not be usable. Contact your local sales office for more details.

8. When unbalanced torque is generated, such as in a vertical lift machine, it is recommended that the unbalanced torque of the machine be kept under 70% of the motor's rated torque.



HA-LP 2000r/min Series Servo Motor Torque Characteristics (400VAC Class)

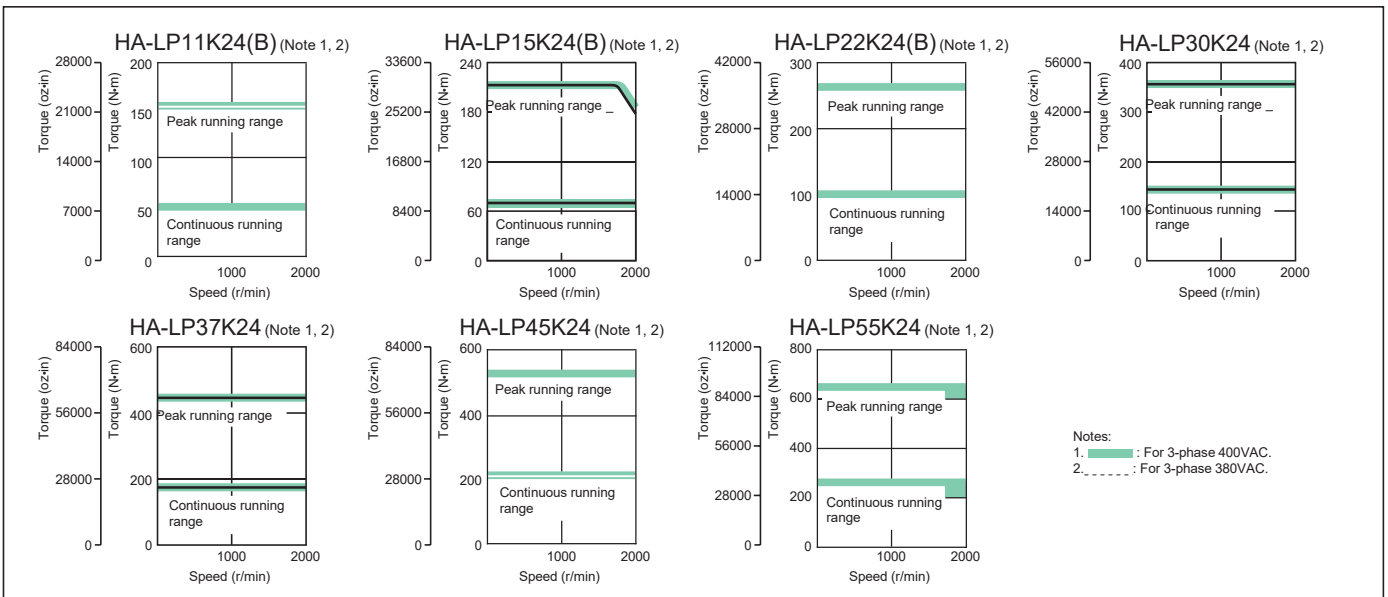

Model designation
 Servo motors
 Servo amplifiers
 Options
 Peripheral equipment
 MR-J3-B Safety
 MR-J3W series
 Servo support software
 Cautions
 Warranty
 Global FA centers

MELSERVO-J3

Servo Motor Dimensions

(Unit: mm)

- HF-KP053(B), HF-KP13(B)
- HF-MP053(B), HF-MP13(B)

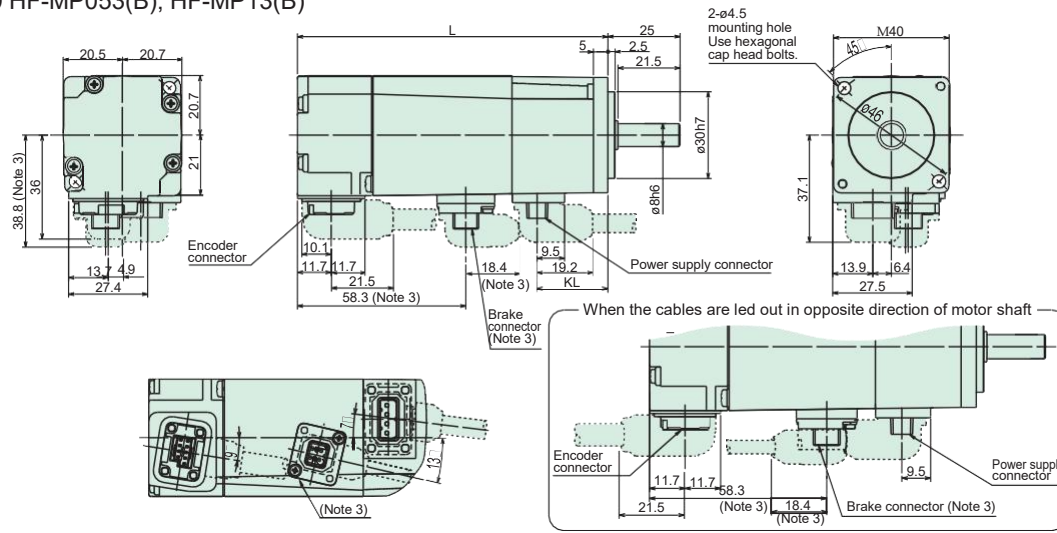

Power supply connector pin assignment

Pin No.	Signal name
1	Earth
2	U
3	V
4	W

Brake connector pin assignment (Note 3)

Pin No.	Signal name
1	B1
2	B2

Model	Variable dimensions	
	L	KL
HF-KP053(B) HF-MP053(B)	66.4 (107.5)	24.5
HF-KP13(B) HF-MP13(B)	82.4 (123.5)	40.5

- HF-KP23(B), HF-KP43(B)
- HF-MP23(B), HF-MP43(B)

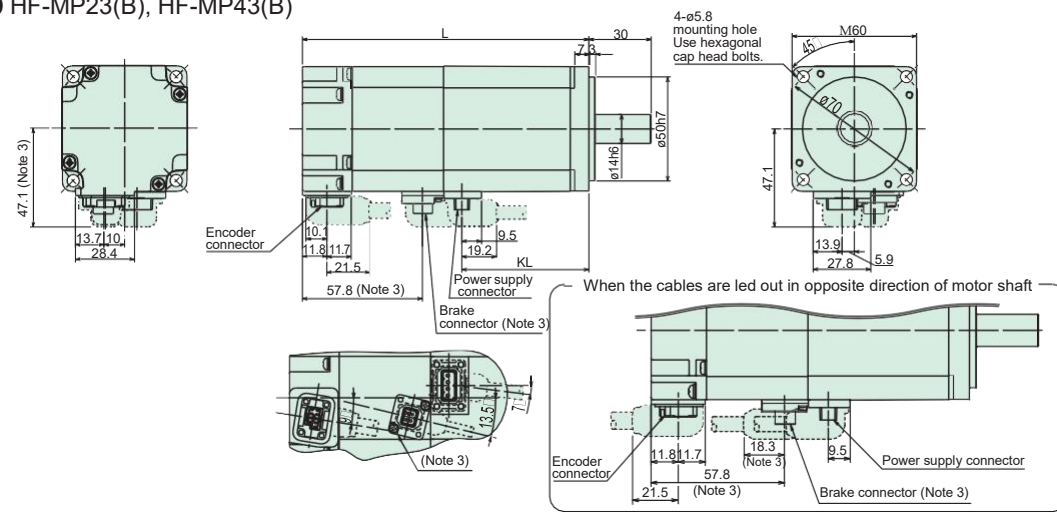

Power supply connector pin assignment

Pin No.	Signal name
1	Earth
2	U
3	V
4	W

Brake connector pin assignment (Note 3)

Pin No.	Signal name
1	B1
2	B2

Model	Variable dimensions	
	L	KL
HF-KP23(B) HF-MP23(B)	76.6 (116.1)	39.3
HF-KP43(B) HF-MP43(B)	98.5 (138)	61.2

- HF-KP73(B)
- HF-MP73(B)

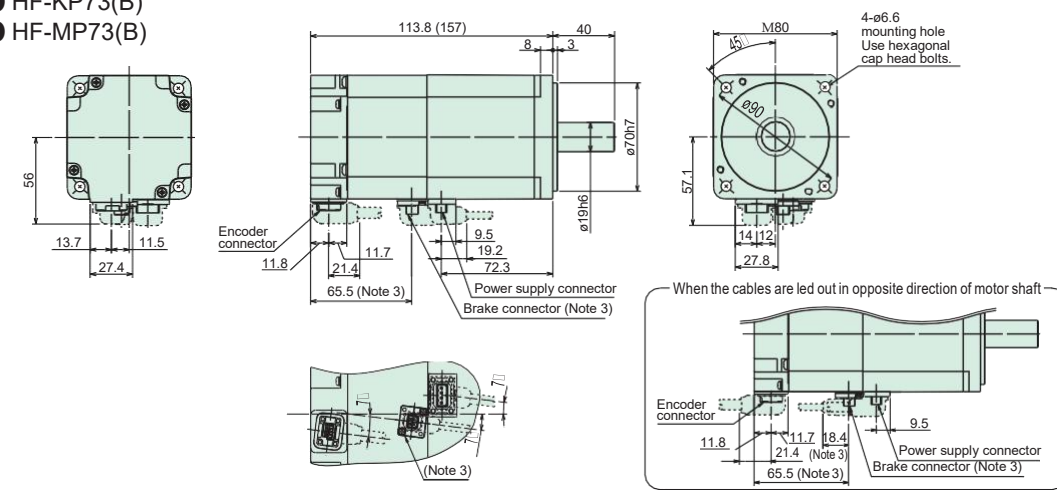

Power supply connector pin assignment

Pin No.	Signal name
1	Earth
2	U
3	V
4	W

Brake connector pin assignment (Note 3)

Pin No.	Signal name
1	B1
2	B2

Notes: 1. Use a friction coupling to fasten a load.
 2. Dimensions inside () are for the models with an electromagnetic brake.
 3. Only for the models with an electromagnetic brake. The electromagnetic brake terminals (B1, B2) do not have polarity.
 4. For dimensions where there is no tolerance listed, use general tolerance.
 5. Dimensions for motors with an oil seal (HF-KPMJ and HF-MPMJ) are different from the above. Contact your local sales office for details.

(Unit: mm)

- HF-SP51(B), HF-SP81(B)
- HF-SP52(B), HF-SP102(B), HF-SP152(B)
- HF-SP524(B), HF-SP1024(B), HF-SP1524(B)

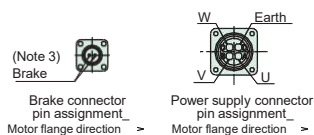
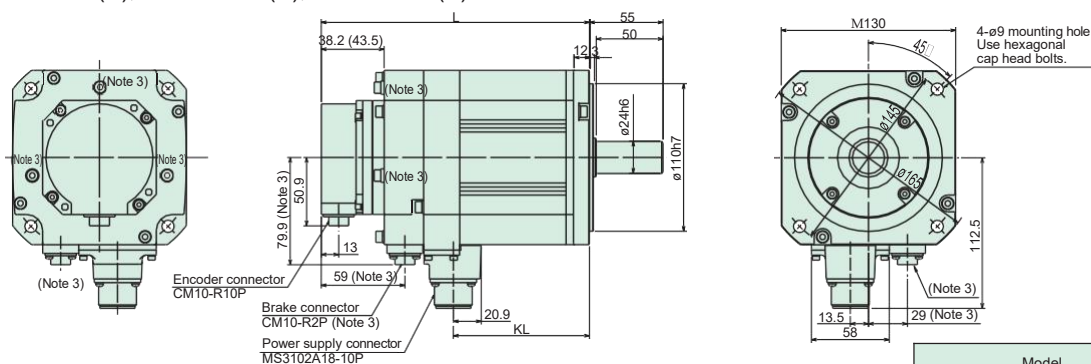

Model		Variable dimensions	
1000r/min	2000r/min	L	KL
—	HF-SP52(4)(B)	118.5 (153)	57.8
HF-SP51(B)	HF-SP102(4)(B)	140.5 (175)	79.8
HF-SP81(B)	HF-SP152(4)(B)	162.5 (197)	101.8

- HF-SP121(B), HF-SP201(B), HF-SP301(B), HF-SP421(B)
- HF-SP202(B), HF-SP352(B), HF-SP502(B), HF-SP702(B)
- HF-SP2024(B), HF-SP3524(B), HF-SP5024(B), HF-SP7024(B)

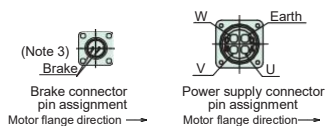
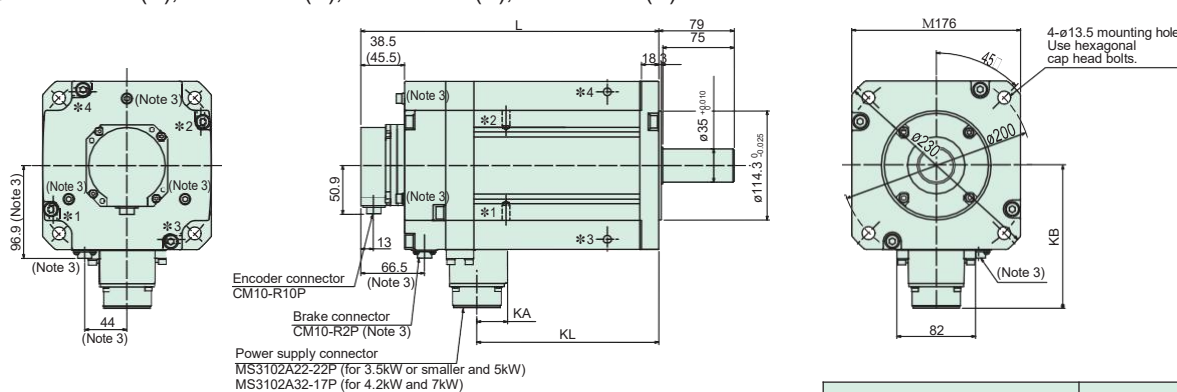

Model		Variable dimensions			
1000r/min	2000r/min	L	KL	KA	KB
HF-SP121(B)	HF-SP202(4)(B)	143.5 (193)	79.8		
HF-SP201(B)	HF-SP352(4)(B)	183.5 (233)	119.8	24.8	140.9
HF-SP301(B)	HF-SP502(4)(B)	203.5 (253)	139.8		
HF-SP421(B)	HF-SP702(4)(B)	263.5 (313)	191.8	32	149.1

- *1, *2, *3 and *4 are screw holes for eyebolt.
- *For HF-SP201(B), HF-SP301(B), HF-SP352(4)(B), HF-SP502(4)(B): *3, *4
- *For HF-SP421(B), HF-SP702(4)(B): *1, *2, *3, *4

- Notes: 1. Use a friction coupling to fasten a load.
 2. Dimensions inside () are for the models with an electromagnetic brake.
 3. Only for the models with an electromagnetic brake. The electromagnetic brake terminals do not have polarity.
 4. For dimensions where there is no tolerance listed, use general tolerance.