

KEYENCE

New Standard!
Metal Mini-Photoeye



NEW

Self-contained Miniature
Photoelectric Sensor

PR-M/F SERIES

New Standard for
Photoelectric Sensors

02

**Value
Priced**



Quick Delivery

LR-Z SERIES



PR-M/F SERIES



NEW

Self-contained Miniature
Photoelectric Sensor

PR-M/F SERIES

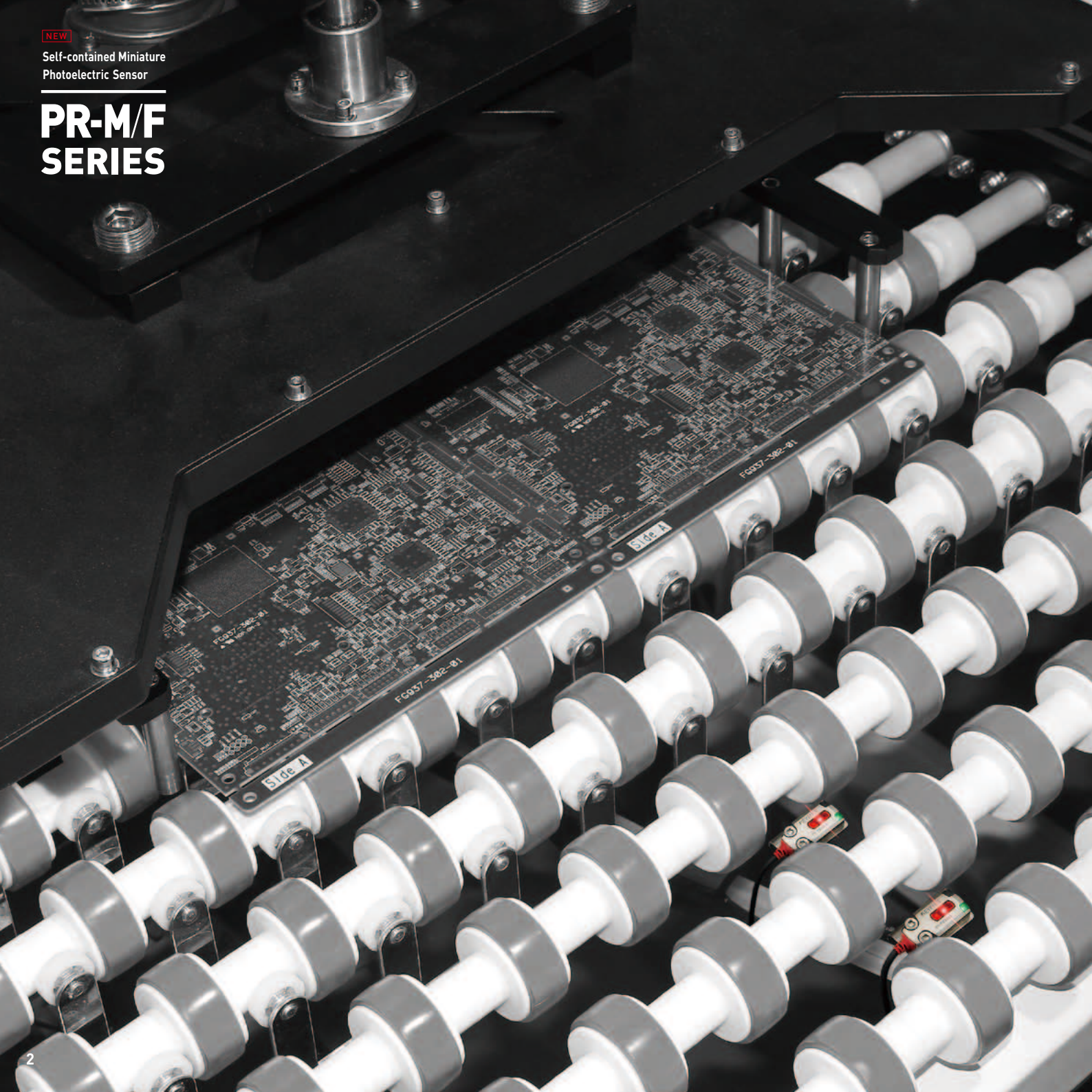

Optimizing miniature photoelectric sensors

Conventional miniature photoelectric sensors typically do not provide long term reliability due to weak structural design and unstable operation. In order to solve these issues, operation stability features including background suppression and automatic cross talk prevention have been combined with a heavy duty metal housing to create a better miniature photoelectric sensor.

DURABLE & LONG LIFE

Resin filled, Stainless steel body (SUS316L)

STABLE OPERATION

Background suppression and
Automatic cross talk prevention

EASE OF USE

Simple installation and
No sensitivity adjustment required

DURABLE & LONG LIFE

Resin filled, Stainless steel body
(SUS316L)



5X

More resistant to
impact than conventional models

Smallest stainless steel photoelectric sensor in its class

The “hybrid structure”, featuring a resin filled, SUS316L stainless steel body, was designed to achieve approximately five times greater shock resistance*. The heavy duty body of the PR-M/F is also highly resistant to oils, acids, and alkaline detergents and can be used in harsh environments due to its NEMA and IP rated enclosure. These features, combined with an 81 percent reduction in size*, result in the smallest, most durable miniature photoelectric sensor in its class.

* Comparison with conventional models.

< Hybrid structure > Stainless steel (SUS316L) + Resin filled body

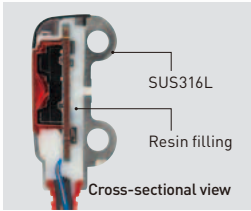

SUS316L
Resin filling
Cross-sectional view



Shock resistance
5X
greater
[Compared to conventional models]

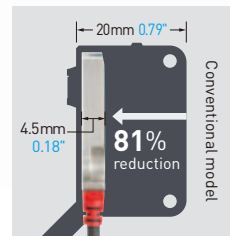

The smallest metal photoeye in its class



IP67/69K, NEMA 4X, 6P, 13

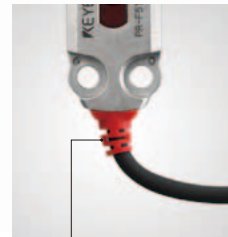

Cable protection

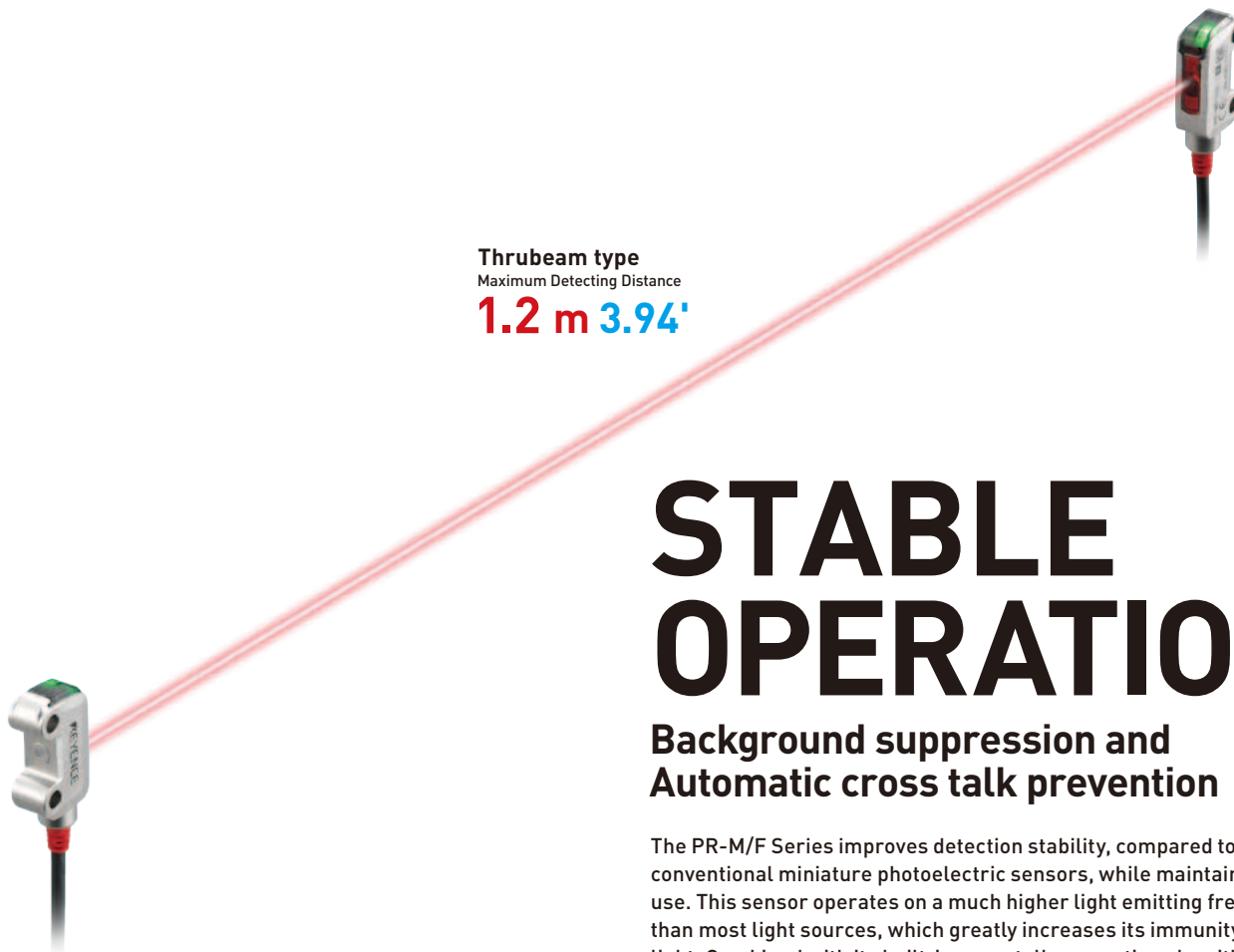

Thru-beam type
 Maximum Detecting Distance
1.2 m 3.94'

STABLE OPERATION

Background suppression and Automatic cross talk prevention

The PR-M/F Series improves detection stability, compared to conventional miniature photoelectric sensors, while maintaining ease of use. This sensor operates on a much higher light emitting frequency than most light sources, which greatly increases its immunity to ambient light. Combined with its built-in cross talk prevention algorithm, the PR-M/F Series eliminates the need to install additional shielding from other light sources. To further improve stability, an automatic power control function has been included to increase/reduce the light intensity of the sensor. Paired with its higher operating frequency and cross talk avoidance functions, this first in industry feature greatly reduces the effect of the target's color or angle to create the most reliable detection ability in its class.

Background suppression type
 Maximum detecting distance

**30 mm 1.18" /
 15 mm 0.59"**

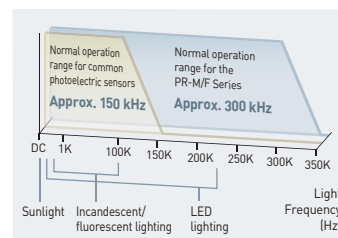

Light frequency comparison

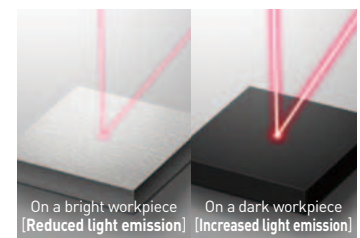

Automatic power control function

EASE OF USE

Simple installation and No sensitivity adjustment required

The PR-M/F was created with ease of use in mind from installation to operation. No special hardware is required as standard M3 screws are used for mounting. All models* feature both Light-on and Dark-on outputs, eliminating the need to maintain multiple part numbers. Once integrated, no sensitivity adjustment is required. Operation is instantly possible and easily monitored with the sensors highly visible indicators.

*Excludes M8 3pin connector type



Highly visible indicators

M3 screw installation



Highly visible indicators



M8 connector types available



Install with standard M3 screws. No special hardware required.

Versatile for use in a wide variety of applications and industries

Improvement application

Presence/absence detection of handfed parts

Before

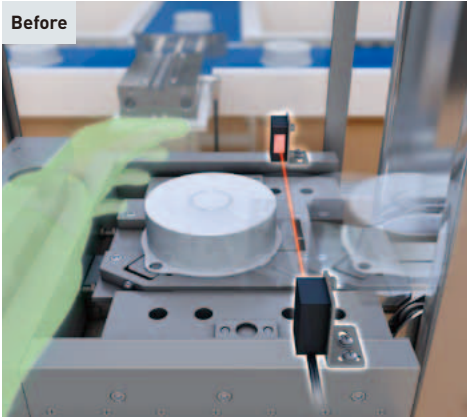

Presence/absence of handfed parts was detected with conventional photoelectric sensors, which interfered with the loading process and resulted in damage.



After

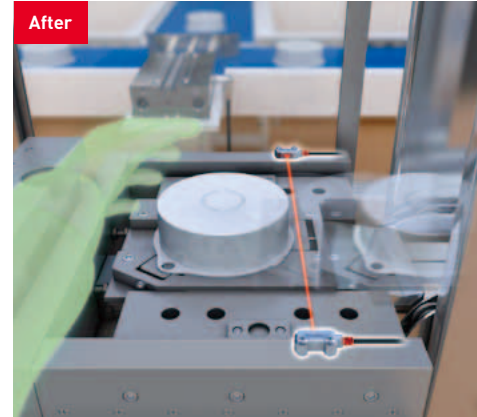

The profile of the sensor is greatly reduced, decreasing the potential for interference with the loading process while the stainless steel body resists damage when impact does occur.

Bowl feeders

Presence/absence confirmation of connectors during parts feeding

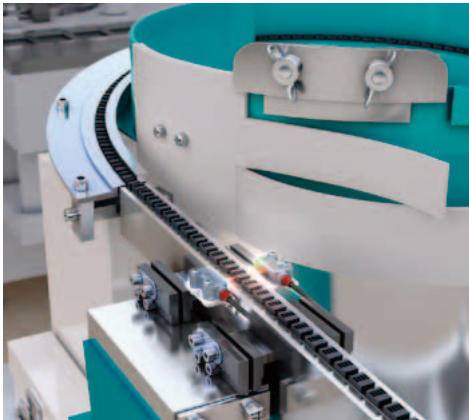

The compact body enables easy installation even in a very narrow space.

Electronics

Detecting improper seating of IC chips

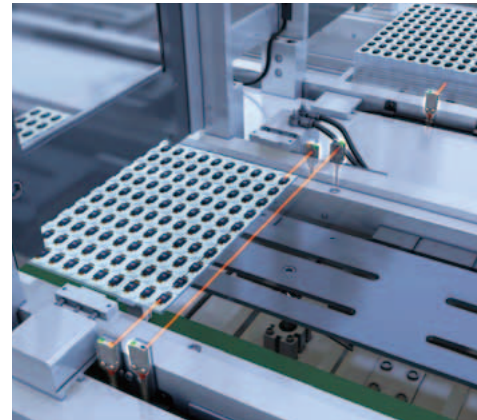

No sensitivity adjustment is required, which allows for quick and simple installation while maintaining completely reliable detection.

Electronics

Arrival confirmation of electronic PCBs

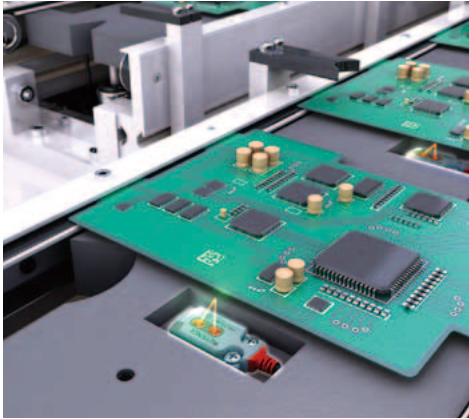

The sensitivity is automatically adjusted according to the light intensity received by the sensor, which reduces the effects of the angle and color of the target, and results in stable operation.

Solar

Presence/absence confirmation of solar substrates

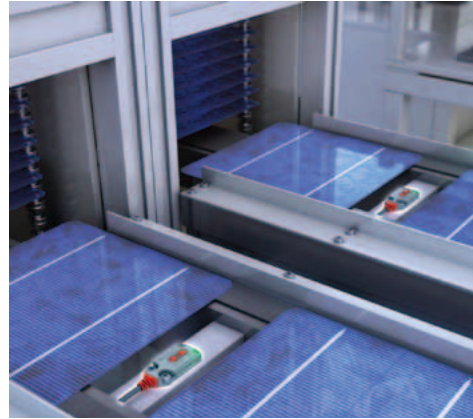

The background suppression function reduces the effects of ambient light, which results in stable detection in all conditions.

Packaging

Passing bottle confirmation on side by side conveyors



Reduced by 81% in size*, the PR-M/F can be installed in extremely narrow spaces.

*Compared to conventional models





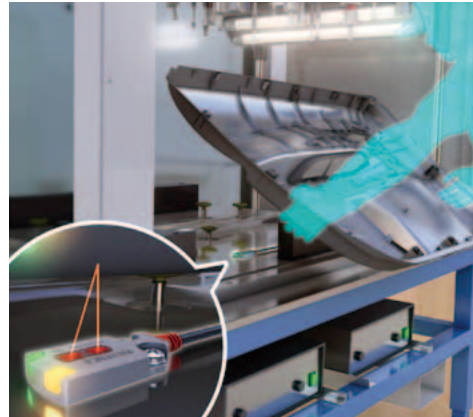







Automotive

Presence/absence confirmation on instrument panels



The equipped background suppression function provides stable detection of components only in the specified operating range, eliminating false detection.

Lineup

Configuration	Type	Detecting distance	Connection method	Cable length	Output	Model	Weight	
Thrubeam	 Miniature slim type	 1.2 m 47.24"	Cable	1 m 3.28'	NPN	PR-M51N1	Approx. 42 g	
				3 m 9.84'	NPN	PR-M51N3	Approx. 90 g	
			M8 4-pin *1	120 mm 4.72" *2	NPN	PR-M51CN		Approx. 26 g
					PNP	PR-M51CP		
					M8 3-pin Light-on *1	PNP	PR-M51C3PL	
					M8 3-pin Dark-on *1	PNP	PR-M51C3PD	
	 Flat type	 0.6 m 23.62"	Cable	1 m 3.28'	NPN	PR-F51N1	Approx. 36 g	
				3 m 9.84'	NPN	PR-F51N3	Approx. 80 g	
			M8 4-pin *1	120 mm 4.72" *2	PNP	PR-F51P3	Approx. 20 g	
					NPN	PR-F51CN		
					PNP	PR-F51CP		
					M8 3-pin Light-on *1	PNP		PR-F51C3PL
M8 3-pin Dark-on *1	PNP	PR-F51C3PD						
Reflective with Background Suppression	 Miniature slim type	 1 to 15 mm 0.04" to 0.59"	Cable	1 m 3.28'	NPN	PR-MB15N1	Approx. 21 g	
				3 m 9.84'	NPN	PR-MB15N3	Approx. 45 g	
			M8 4-pin *1	120 mm 4.72" *2	PNP	PR-MB15P3	Approx. 13 g	
					NPN	PR-MB15CN		
					PNP	PR-MB15CP		
					M8 3-pin Light-on *1	PNP		PR-MB15C3PL
	 Miniature slim type	 1 to 30 mm 0.04" to 1.18"	Cable	1 m 3.28'	NPN	PR-MB30N1	Approx. 21 g	
				3 m 9.84'	NPN	PR-MB30N3	Approx. 45 g	
			M8 4-pin *1	120 mm 4.72" *2	PNP	PR-MB30P3	Approx. 13 g	
					NPN	PR-MB30CN		
					PNP	PR-MB30CP		
					M8 3-pin Light-on *1	PNP		PR-MB30C3PL
	 Flat type	 1 to 15 mm 0.04" to 0.59"	Cable	1 m 3.28'	NPN	PR-FB15N1	Approx. 18 g	
				3 m 9.84'	NPN	PR-FB15N3	Approx. 40 g	
			M8 4-pin *1	120 mm 4.72" *2	PNP	PR-FB15P3	Approx. 10 g	
					NPN	PR-FB15CN		
					PNP	PR-FB15CP		
					M8 3-pin Light-on *1	PNP		PR-FB15C3PL
 Flat type	 1 to 30 mm 0.04" to 1.18"	Cable	1 m 3.28'	NPN	PR-FB30N1	Approx. 18 g		
			3 m 9.84'	NPN	PR-FB30N3	Approx. 40 g		
		M8 4-pin *1	120 mm 4.72" *2	PNP	PR-FB30P3	Approx. 10 g		
				NPN	PR-FB30CN			
				PNP	PR-FB30CP			
				M8 3-pin Light-on *1	PNP		PR-FB30C3PL	

*1 Cable is sold separately.

*2 Length between the main unit and connector.

■ Extension Cable

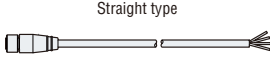
Specifications	Material	Appearance	Connection method	Length	Model	Weight
Standard	Cable: PVC Connector: Brass nickel plating	 <p style="text-align: center;">Straight type</p>	M8 4-pin	2 m 6.56'	OP-73864	55 g
				10 m 32.81'	OP-73865	220 g
	Cable: PVC Connector: Zinc nickel plating		M8 3-pin	2 m 6.56'	OP-87627	80 g
Chemical resistant	Cable: PVC Connector: SUS316L		M8 4-pin	2 m 6.56'	OP-87621	75 g
			M8 3-pin	2 m 6.56'	OP-87622	60 g

■ Enclosure ratings

Enclosure rating	Conector type		Cable type
	w/ standard extension cable	w/ chemical resistant extension cable	
IP67 IEC60529	✓	✓	✓
IP69K DIN40050-9	-	-	✓
ECOLAB, Diversey	-	✓*	✓*

* Have passed resistance tests with cleaning agents from multiple manufactures.

■ I/O circuit diagram

NPN type : Reflective & Thrubeam receiver

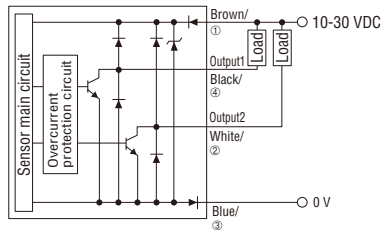

PNP type : Reflective & Thrubeam receiver

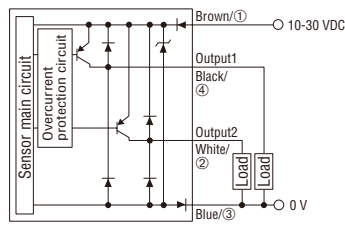

Thrubeam transmitter

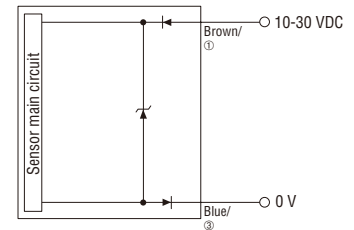





M8 Connector pin layout (4-pin type)









M8 Connector pin layout (3-pin type)



■ Mounting bracket



Type	Model	Material/Weight
 Flat type standard mounting bracket (M3 screw x 2 supplied) Qty: 1	PR-B01	SUS316L Approx. 8 g
 Flat type rear mounting bracket (M3 screw x 2 supplied) Qty: 1	PR-B02	SUS316L Approx. 10 g
 Miniature slim type standard mounting bracket (M3 screw x 2, plate nut supplied) Qty: 1	PR-B03	SUS316L Approx. 8 g
 Miniature slim type rear mounting bracket (M3 screw x 2, plate nut supplied) Qty: 1	PR-B04	SUS316L Approx. 10 g
 Miniature slim type side mounting bracket (M3 screw x 2, plate nut supplied) Qty: 1	PR-B05	

■ Accessory

Type	Model	Material/Weight
 Plate nut (for the flat type) Qty: 2 (M3 screw x 4 supplied)	OP-87667	SUS316L Approx. 1 g
 Plate nut (for the miniature slim type) Qty: 2 (M3 screw x 4 supplied)	OP-87668	SUS316L Approx. 2 g
 Spacer (for the flat type) Qty: 2 x 2 (M3 screw x 4 supplied)	OP-87669	SUS303 Approx. 1 g
 Slit, ø0.5 (for the flat type) Qty: 1 Detecting distance: 30 mm 1.18" *	OP-87670	SUS304 Approx. 1 g
 Slit, 0.5 x 3 (for the flat type) Qty: 1 Detecting distance: 120 mm 4.72" *	OP-87671	
 Slit, ø0.5 (for the miniature slim type) Qty: 1 Detecting distance: 30 mm 1.18" *	OP-87672	
 Slit, 0.5 x 3 (for the miniature slim type) Qty: 1 Detecting distance: 180 mm 7.09" *	OP-87673	

* Dedicated to the thrubeam type. The detecting distance is when attached to both the transmitter and receiver.

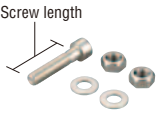
■ Mounting bracket (adjustable bracket)

Type	Model	Material/Weight
 Adjustable bracket for the miniature slim type (M3 screw x 2 supplied)	OP-87404	Zinc nickel plating Approx. 95 g
 Locking screw for adjustable bracket Screw length Locking screw for adjustable bracket	Screw length: 45 mm 1.77"	OP-87406 Iron nickel plating Approx. 70 g
	Screw length: 65 mm 2.56"	OP-87407 Iron nickel plating Approx. 80 g
 Adjustable mount for the flat type mounting bracket	OP-87664	Zinc nickel plating and others Approx. 190 g
 Mounting bracket for the flat type (M3 screw x 4, plate nut x 1 for the compact slim/flat types supplied)	200 mm 7.87"	OP-87665 SUS304 Approx. 77 g
	130 mm 5.12"	OP-87666 SUS304 Approx. 50 g



Specifications



Appearance		Miniature slim				Flat		
Type		Thrubeam	Reflective with Background Suppression		Thrubeam	Reflective with Background Suppression		
Model	NPN output	Cable (1 m 3.28')	PR-M51N1	PR-MB15N1	PR-MB30N1	PR-F51N1	PR-FB15N1	PR-FB30N1
		Cable (3 m 9.84')	PR-M51N3	PR-MB15N3	PR-MB30N3	PR-F51N3	PR-FB15N3	PR-FB30N3
		M8 connector 4-pin	PR-M51CN	PR-MB15CN	PR-MB30CN	PR-F51CN	PR-FB15CN	PR-FB30CN
		M8 connector 3-pin	—					
	PNP output	Cable (1 m 3.28')	—					
		Cable (3 m 9.84')	PR-M51P3	PR-MB15P3	PR-MB30P3	PR-F51P3	PR-FB15P3	PR-FB30P3
		M8 connector 4-pin	PR-M51CP	PR-MB15CP	PR-MB30CP	PR-F51CP	PR-FB15CP	PR-FB30CP
		M8 connector 3-pin*1	PR-M51C3PD PR-M51C3PL	PR-MB15C3PL	PR-MB30C3PL	PR-F51C3PD PR-F51C3PL	PR-FB15C3PL	PR-FB30C3PL
Detectable distance		1.2 m 3.94'	1 to 15 mm 0.04" to 0.59"	1 to 30 mm 0.04" to 1.18"	0.6 m 1.97'	1 to 15 mm 0.04" to 0.59"	1 to 30 mm 0.04" to 1.18"	
Max. distance at which the sensor turns OFF (white paper*2)		—	20 mm 0.79'	43 mm 1.69'	—	20 mm 0.79'	47 mm 1.85'	
No. of control outputs*1		2 : 1 Light-ON, 1 Dark-ON						
Output operation*1	Output 1	Dark-ON	Light-ON		Dark-ON	Light-ON		
	Output 2	Light-ON	Dark-ON		Light-ON	Dark-ON		
Response time*1	Output 1	ON -> OFF: 0.5 ms, OFF -> ON: 0.5 ms						
	Output 2	ON -> OFF: 2.7 ms, OFF -> ON: 0.5 ms						
Sensitivity adjustment		None						
Spot diameter		—	Approx. ø3 mm ø0.12" (at 15 mm 0.59")	Approx. ø5.5 mm ø0.22" (at 30 mm 0.18")	—	Approx. 2.5 x 4.5 mm 0.10" x 0.18" (at 15 mm 0.59")	Approx. ø5 mm 0.20" (at 30 mm 0.18")	
Light source		4 element, Red LED (650 nm)						
Mutual interference prevention		—	4 units		—	4 units		
Indicator		Output indicator (orange), Stable operation indicator (green), Thrubeam transmitter: power indicator (green)						
Power voltage		10 to 30 VDC, including 10% ripple (P-P)						
Power consumption		Transmitter: 11 mA Receiver: 16 mA	19 mA		Transmitter: 11 mA Receiver: 16 mA	19 mA		
Control output		NPN output type: NPN open collector, PNP output type: PNP open collector 30 VDC or less, 50 mA or less Residual voltage: 1.0 V or less at 10 mA or less, 1.5 V or less at 10 to 30 mA, 2.0 V or less at 30 to 50 mA Leakage current: 0.3 mA or less at 3 kΩ of load resistance, 0.5 mA or less at 1 kΩ of load resistance, 1.5 mA or less at 0.2 kΩ of load resistance						
Protection circuit		Protection against reverse power connection, output overcurrent, power supply surge, output surge						
Environmental resistance	Enclosure rating	IP67 (IEC60529), IP69K (DIN40050-9)*3, 4X, 6P, 13 (NEMA250)						
	Ambient light	Incandescent lamp: 5000 lux or less, Sunlight: 20000 lux or less						
	Ambient temperature	-25 to +55°C -13°F to +131°F (No freezing)						
	Storage temperature	-25 to +75°C -13°F to +167°F						
	Ambient humidity	35 to 85% RH (No condensation)						
	Shock resistance	1000 m/s ² in X, Y, Z axis directions respectively 6 times						
	Vibration resistance	10 to 55 Hz, 1.5 mm 0.06" double amplitude in the X, Y, and Z directions, 2 hours respectively						
	Insulating resistance	20 MΩ or more (500 VDC)						
Withstand voltage	1000 VAC, 50/60 Hz, 1 min							
Material		Case: SUS316L, Indicator cover/Lens cover: Polysulfone, Cable: PVC, Cable protection: PMP, Filler: Polyester resin, Connector (connector type only): Brass nickel plating/Polyester elastomer						
Weight	1 m 3.28' cable	Approx. 42 g	Approx. 21 g		Approx. 36 g	Approx. 18 g		
	3 m 9.84' cable	Approx. 90 g	Approx. 45 g		Approx. 80 g	Approx. 40 g		
	M8 connector	Approx. 26 g	Approx. 13 g		Approx. 20 g	Approx. 10 g		
Accompanying items		Instruction Manual						

*1 The M8 connector (3 pin) type has 1 control output. If "D" is at the end of the part number, the sensor is equipped with a Dark-ON output. If "L" is at the end of the part number, the sensor is equipped with a Light-ON output. Example: The PR-M51C3PL has a Light-ON output.

*2 Typical value.

*3 Cable type only.

**PR-F51N1/
F51N3/F51P3**

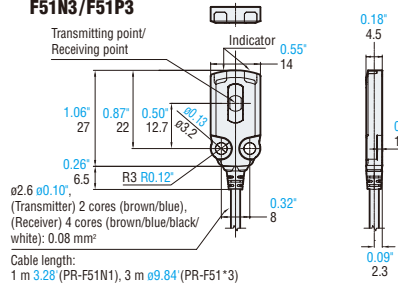

**PR-FB15N1/FB30N1
FB15N3/FB15P3/
FB30N3/FB30P3**

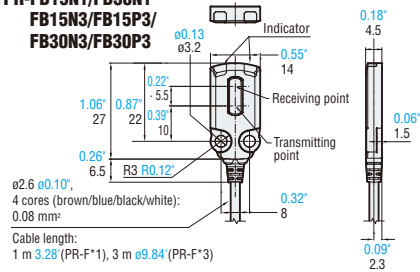

**PR-F51CN/F51CP/
F51C3PL/F51C3PD**

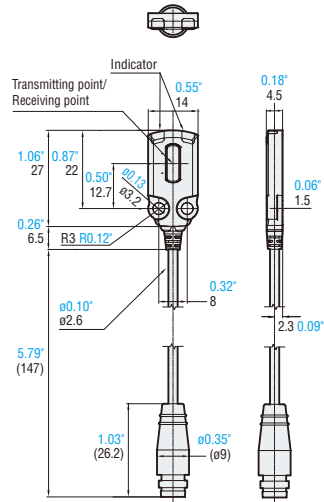

**PR-FB15CN/FB15CP/FB30CN/FB30CP/
FB15C3PL/FB30C3PL**

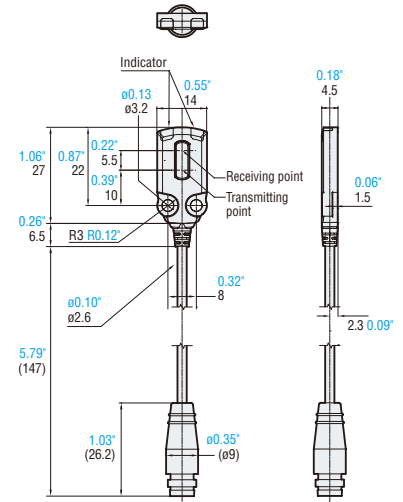

**PR-M51N1/
M51N3/M51P3**

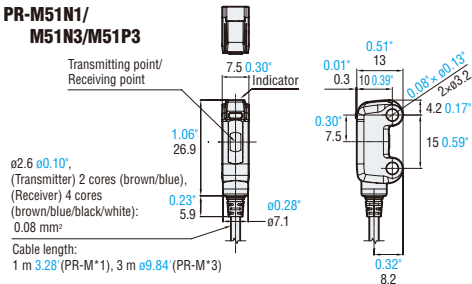

**PR-M51CN/M51CP/
M51C3PL/M51C3PD**

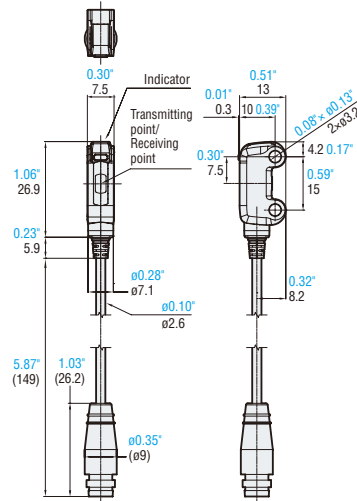

**PR-MB15CN/MB15CP/MB30CN/
MB30CP/MB15C3PL/MB30C3PL**

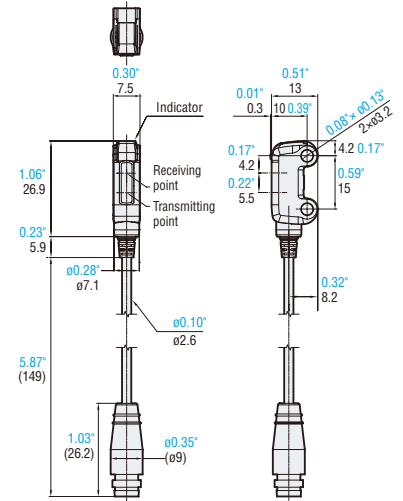

**PR-MB15N1/MB30N1/
MB15N3/MB15P3/
MB30N3/MB30P3**

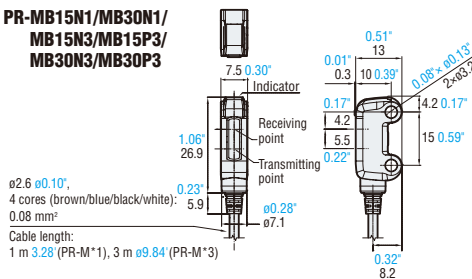

OP-87670

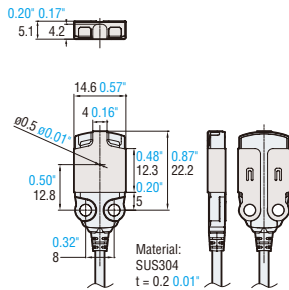

OP-87671

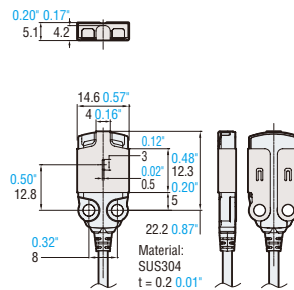

OP-87672

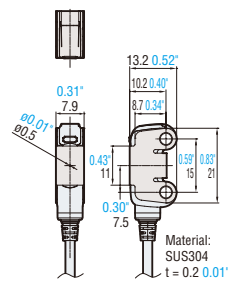

OP-87673

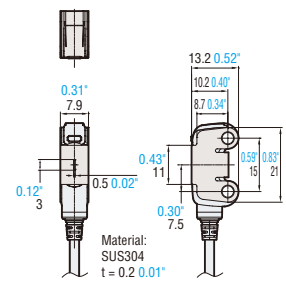

OP-87667

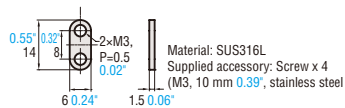

OP-87668

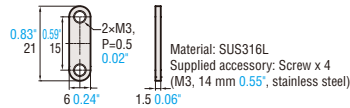

OP-87669

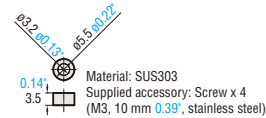

PR-B01

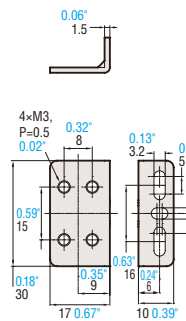

Material: SUS316L
Supplied accessory: Screw x 2 (M3, 6 mm 0.24', stainless steel)

PR-B02

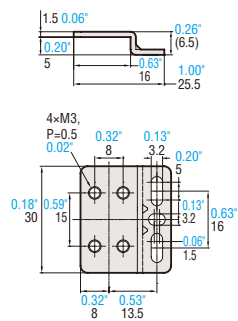

Material: SUS316L
Supplied accessory: Screw x 2 (M3, 6 mm 0.24', stainless steel)

PR-B03

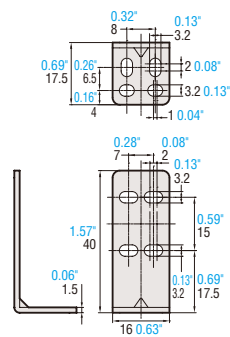

Material: SUS316L
Supplied accessory: Screw x 2 (M3, 12 mm 0.47', stainless steel), Plate nut (SUS316L)

PR-B04

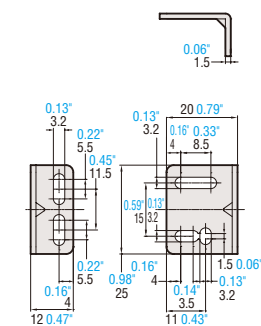

Material: SUS316L
Supplied accessory: Screw x 2 (M3, 14 mm 0.55', stainless steel), Plate nut (SUS316L)

PR-B05

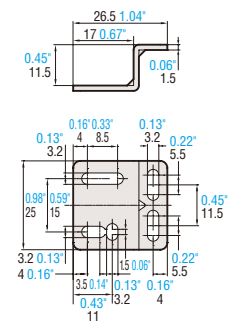

Material: SUS316L
Supplied accessory: Screw x 2 (M3, 14 mm 0.55', stainless steel), Plate nut (SUS316L)

OP-73864 / 73865

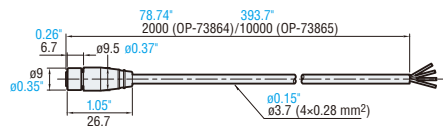

OP-87621

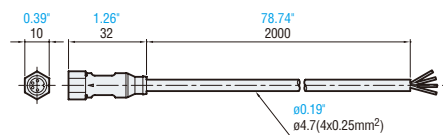

OP-87622

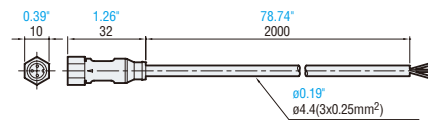

OP-87627

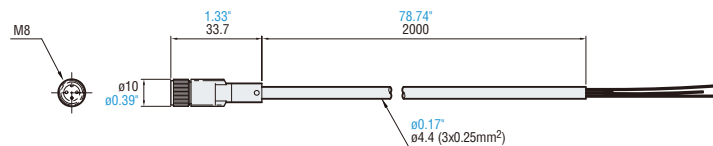

M8 Connector pin layout (4-pin type)



M8 Connector pin layout (3-pin type)



No.	Color
①	Brown
②	White
③	Blue
④	Black

CAD DATA DOWNLOAD
www.keyence.com/CADG

SELF-CONTAINED PHOTOELECTRIC SENSOR

PZ-G Series LED

High power, self contained photoelectric sensors



Optical axis adjustment is simple with the built-in alignment indicator



One-touch mounting bracket simplifies installation



Laser marked tags eliminate possible contamination caused by deteriorating paint or sticker type labels

Detecting distance	High-Power Dual LED-type	4-element red LED-type		
	High-power thru-beam type PZ-G52	Thru-beam type PZ-G51	Reflective type PZ-G41	Retro-reflective type PZ-G61
	40 m 131.2'	20 m 65.6'	1 m 3.3'	1 m 3.3'

SELF-CONTAINED CMOS LASER SENSOR

LR-Z Series CMOS Laser

All-Purpose Laser Photoeye



Best Detection Ability
in its class with CMOS
laser stability



High enclosure rating and
Stainless steel body (SUS316L)
ensure durability and long life



One-touch setup and Digital
display simplify operation

**Detecting
distance**

Short-range type

LR-ZB100 **35 to 100 mm 1.38 to 3.94"**

Long-range type

LR-ZB250 **35 to 250 mm 1.38 to 9.84"**



Self-contained
CMOS Laser Sensor

LR-Z SERIES



Self-contained Miniature
Photoelectric Sensor

PR-M/F SERIES



**CALL
TOLL
FREE**

TO CONTACT YOUR LOCAL OFFICE
1-888-KEYENCE
1 - 8 8 8 - 5 3 9 - 3 6 2 3

www.keyence.com



SAFETY INFORMATION

Please read the instruction manual carefully in order to safely operate any KEYENCE product.

CONTACT YOUR NEAREST OFFICE FOR RELEASE STATUS

KEYENCE CORPORATION OF AMERICA

Head Office 500 Park Boulevard, Suite 200, Itasca, IL 60143, U.S.A. **PHONE:** +1-201-930-0100 **FAX:** +1-855-539-0123 E-mail: keyence@keyence.com

AL Birmingham	CA San Jose	CO Denver	IL Chicago	MI Detroit	MO St. Louis	NC Raleigh	PA Philadelphia	TN Nashville	WI Milwaukee
AR Little Rock	CA Cupertino	FL Tampa	IN Indianapolis	MI Grand Rapids	NJ Elmwood Park	OH Cincinnati	PA Pittsburgh	TX Austin	
AZ Phoenix	CA Los Angeles	GA Atlanta	KY Louisville	MN Minneapolis	NY Rochester	OH Cleveland	SC Greenville	TX Dallas	
CA San Francisco	CA Irvine	IA Iowa	MA Boston	MO Kansas City	NC Charlotte	OR Portland	TN Knoxville	WA Seattle	

KEYENCE CANADA INC.

Head Office PHONE: +1-905-366-7655 FAX: +1-905-366-1122 E-mail: keyencecanada@keyence.com
Montreal PHONE: +1-514-694-4740 FAX: +1-514-694-3206 Windsor PHONE: +1-905-366-7655 FAX: +1-905-366-1122

KEYENCE MEXICO S.A. DE C.V.

PHONE: +52-55-8850-0100 FAX: +52-81-8220-9097
E-mail: keyencemexico@keyence.com

The information in this publication is based on KEYENCE's internal research/evaluation at the time of release and is subject to change without notice.
Company and product names mentioned in this catalog are either trademarks or registered trademarks of their respective companies.
The specifications are expressed in metric units. The English units have been converted from the original metric units.

Copyright (c) 2012 KEYENCE CORPORATION. All rights reserved.

KA1-1017

PR-KA-C-US 1093-3 [611684](#)