

HG-C SERIES

Related Information

- General terms and conditions..... F-3
- Selection guide..... P.169~
- Glossary of terms/General precautions P.1549~/P.1552~
- About laser beam..... P.1593~

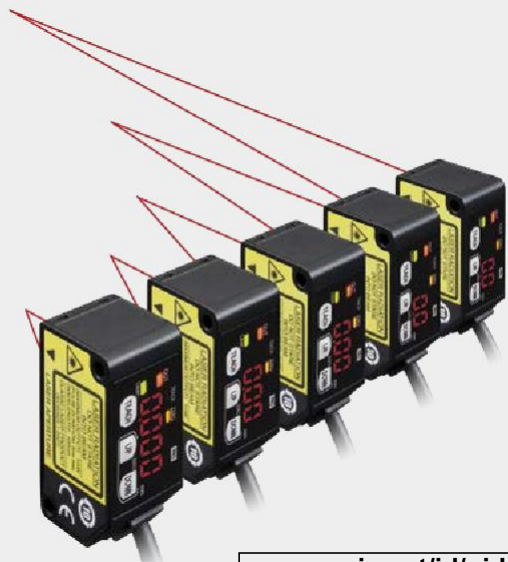

panasonic.net/id/pidsx/global



Warning: This product is classified as a Class 2 Laser Product under IEC/JIS/GB standards and FDA regulations. Do not look at the laser beam directly or through an optical system such as a lens.

* This product complies with 21 CFR 1040.10 and 1040.11 Laser Notice No. 50, dated June 24, 2007, issued by CDRH (Center for Devices and Radiological Health) under the FDA (Food and Drug Administration).



Reliable detection in repeatability 10 μm 0.394 mil

Overwhelmingly stable

Fitted with a precise CMOS image sensor and an original algorithm

Thanks to a precise CMOS image sensor,

it is now possible to perform highly precise measurements in the order of 1/100 mm 0.0003 in. The existing adjustable range reflective sensors cannot achieve such accuracy.

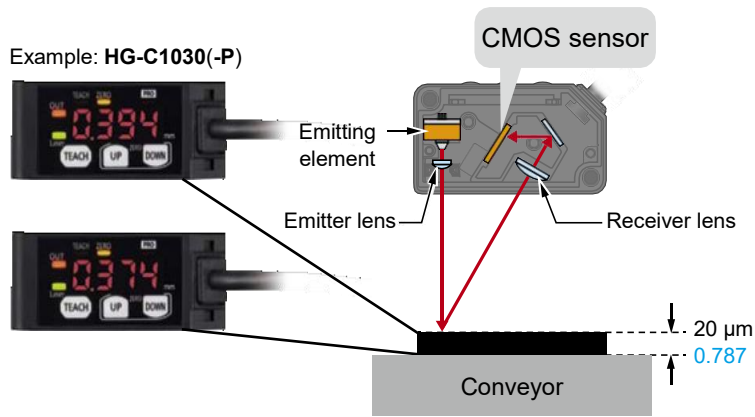

Repeatability 10 μm (0.394 mil)
[HG-C1030(-P)]

mil

- Selection Guide
- Amplifier Built-in
- Amplifier-separated

- EX-L200
- HG-C

APPLICATIONS

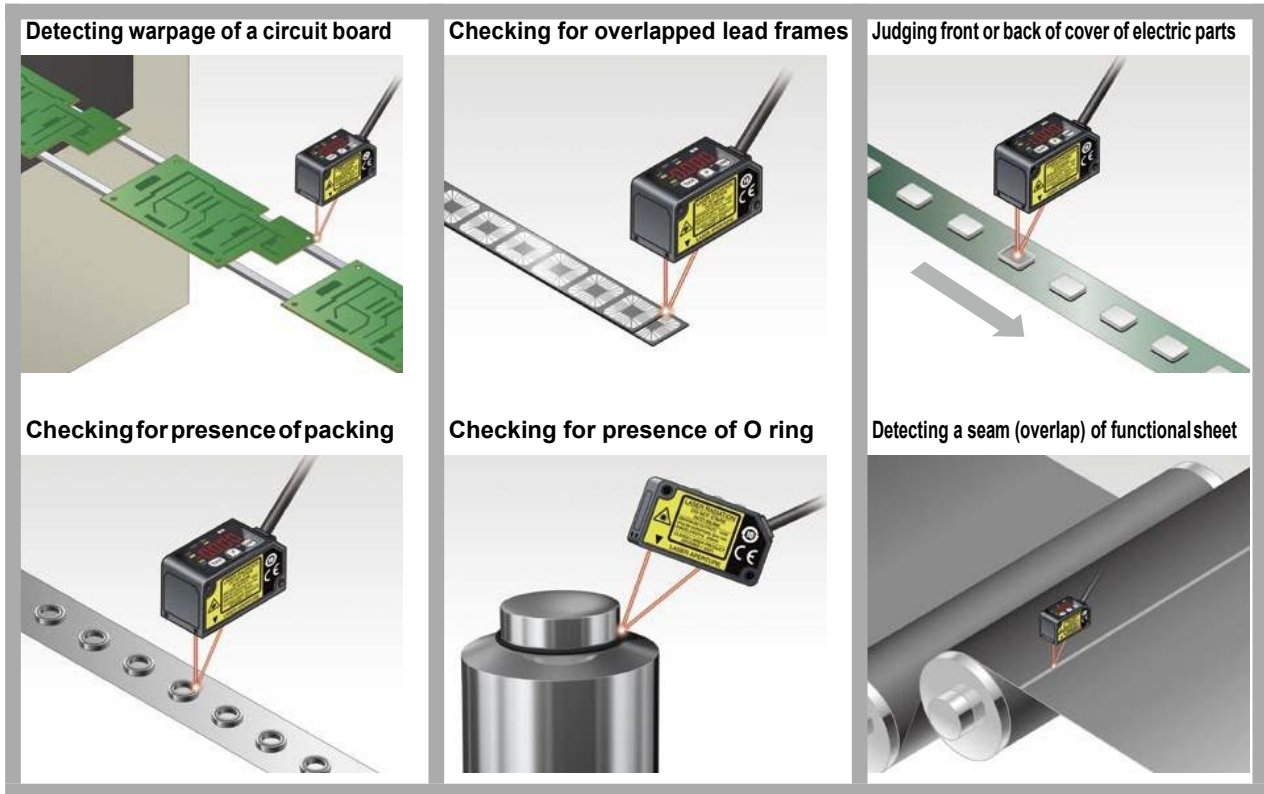

Compact and light-weight

The **HG-C** series is the smallest CMOS laser sensor in industry *. W20 × H44 × D25 mm **W0.787 × H1.732 × D0.984 in**, 35 g approx. (without cable)

* As of May 2015, in-company survey.

A new optical system with a built-in mirror

In general, more accurate and stable measurements can be obtained by increasing the optical path length between the light-receiving part and the light receiving element (CMOS), but this also increases the sensor depth and the sensor body gets bigger.

The **HG-C** series sensors incorporating a new optical system with a built-in mirror provides smaller sensor depth as well as higher measurement accuracy equivalent to displacement sensors.

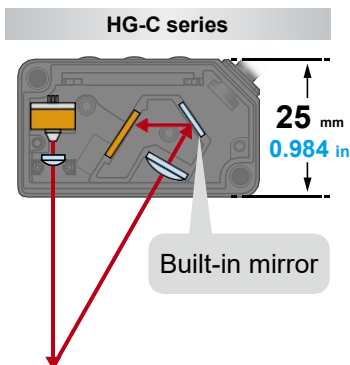

Controlling the dispenser head height

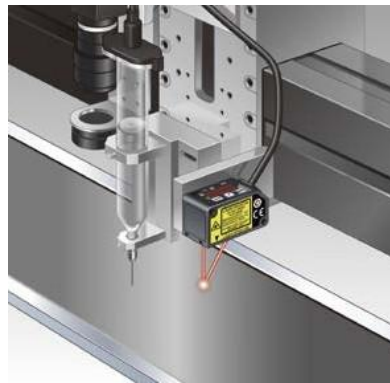

Controlling the mounter head height

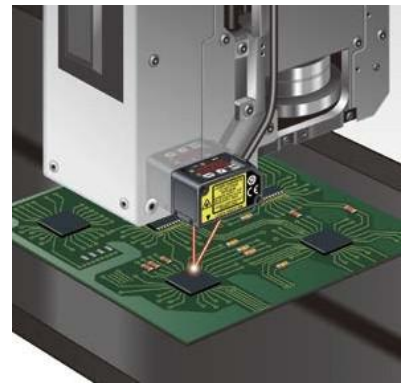

Controlling the parallel link robot height

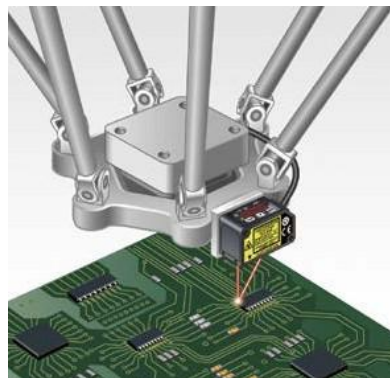

Installable on a food packaging line where water splashes (IP67)



Remove water droplets on detection surface to achieve correct measurement.

FIBER SENSORS

LASER SENSORS

PHOTOELECTRIC SENSORS

MICRO PHOTOELECTRIC SENSORS

AREA SENSORS

SAFETY LIGHT CURTAINS / SAFETY COMPONENTS

PRESSURE / FLOW SENSORS

INDUCTIVE PROXIMITY SENSORS

PARTICULAR USE SENSORS

SENSOR OPTIONS

SIMPLE WIRE-SAVING UNITS

WIRE-SAVING SYSTEMS

MEASUREMENT SENSORS

STATIC CONTROL DEVICES

LASER MARKERS

PLC

HUMAN MACHINE INTERFACES

ENERGY MANAGEMENT SOLUTIONS

FA COMPONENTS

MACHINE VISION SYSTEMS

UV CURING SYSTEMS

Selection Guide

Amplifier Built-in

Amplifier-separated

EX-L200

HG-C

- FIBER SENSORS
- LASER SENSORS**
- PHOTOELECTRIC SENSORS
- MICRO PHOTOELECTRIC SENSORS
- AREA SENSORS
- SAFETY LIGHT CURTAINS / SAFETY COMPONENTS
- PRESSURE / FLOW SENSORS
- INDUCTIVE PROXIMITY SENSORS
- PARTICULAR USE SENSORS
- SENSOR OPTIONS
- SIMPLE WIRE-SAVING UNITS
- WIRE-SAVING SYSTEMS
- MEASUREMENT SENSORS
- STATIC CONTROL DEVICES
- LASER MARKERS
- PLC
- HUMAN MACHINE INTERFACES
- ENERGY MANAGEMENT SOLUTIONS
- FA COMPONENTS
- MACHINE VISION SYSTEMS
- UV CURING SYSTEMS

An aluminum die-cast enclosure protects from strain and heat

A light-weight but strong die-cast aluminum enclosure has been adopted. A compact, solid body enclosure reduces the impact of strain and heat on the measurement accuracy.

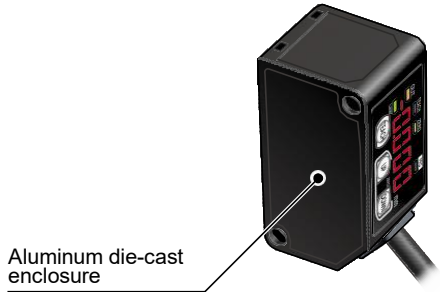

Long distance measurement

Measurement center 400 mm 15.748 in type **HG-C1400(-P)** and 200 mm 7.874 in type **HG-C1200(-P)** are available.

Detecting on-vehicle seats



Judging front or back of cover of cast parts

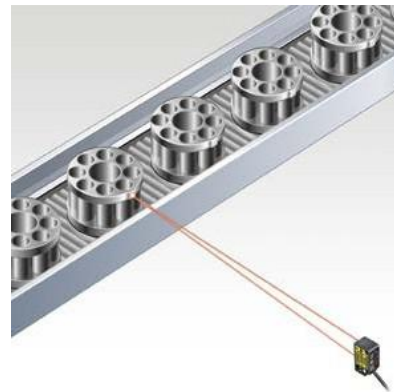

Measurement of a remaining functional sheet

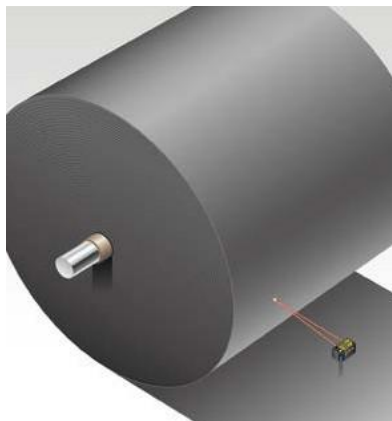

Detecting parts through a viewing port



- Selection Guide
- Amplifier Built-in
- Amplifier-separated
- EX-L200**
- HG-C**

Equipped with 0 to +5 V analog output and 4 to 20 mA analog current output

The value can be measured with a distance measurement sensor.
 Linearity: $\pm 0.1\% \text{ F.S.}^*$
 Temperature characteristics: $0.03\% \text{ F.S./}^\circ\text{C}$

*HG-C1030(-P) / HG-C1050(-P) / HG-C1100(-P)

The sensor not only indicates measured values in mm but also produces analog outputs. Various calculations and storage (logging) can be performed when output is taken into a PLC + analog unit.

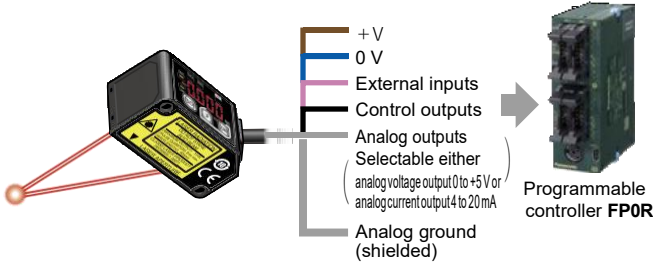

- FP0R-C10 control unit (with RS232C port) AFP0RC10CRS
- A/D converter unit with input channels (terminal block type) AFP0RAD8

■ Linearity characteristics [Typical example: HG-C1030(-P)]

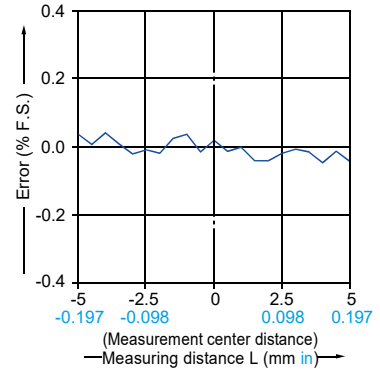

Measuring the hoop slack

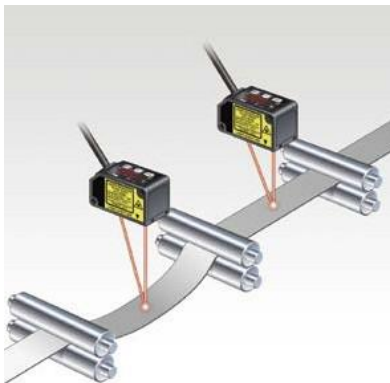

Measuring the insertion depth of an actuator

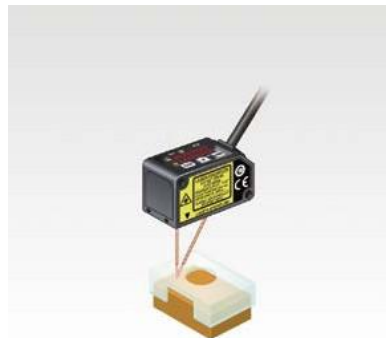

Measuring the thickness of a panel

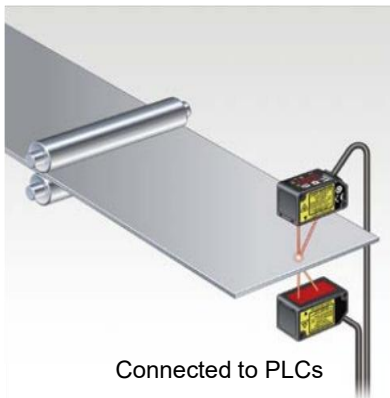

Measuring the thickness of a part

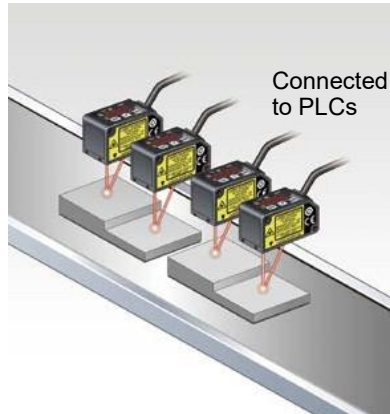

- FIBER SENSORS
- LASER SENSORS
- PHOTOELECTRIC SENSORS
- MICRO PHOTOELECTRIC SENSORS
- AREA SENSORS
- SAFETY LIGHT CURTAINS / SAFETY COMPONENTS
- PRESSURE / FLOW SENSORS
- INDUCTIVE PROXIMITY SENSORS
- PARTICULAR USE SENSORS
- SENSOR OPTIONS
- SIMPLE WIRE-SAVING UNITS
- WIRE-SAVING SYSTEMS
- MEASUREMENT SENSORS
- STATIC CONTROL DEVICES
- LASER MARKERS
- PLC
- HUMAN MACHINE INTERFACES
- ENERGY MANAGEMENT SOLUTIONS
- FA COMPONENTS
- MACHINE VISION SYSTEMS
- UV CURING SYSTEMS

Selection Guide
Amplifier Built-in
Amplifier-separated

EX-L200

HG-C

- FIBER SENSORS
- LASER SENSORS
- PHOTOELECTRIC SENSORS
- MICRO PHOTOELECTRIC SENSORS
- AREA SENSORS
- SAFETY LIGHT CURTAINS / SAFETY COMPONENTS
- PRESSURE / FLOW SENSORS
- INDUCTIVE PROXIMITY SENSORS
- PARTICULAR USE SENSORS
- SENSOR OPTIONS
- SIMPLE WIRE-SAVING UNITS
- WIRE-SAVING SYSTEMS
- MEASUREMENT SENSORS
- STATIC CONTROL DEVICES
- LASER MARKERS
- PLC
- HUMAN MACHINE INTERFACES
- ENERGY MANAGEMENT SOLUTIONS
- FA COMPONENTS
- MACHINE VISION SYSTEMS
- UV CURING SYSTEMS
- Selection Guide
- Amplifier Built-in
- Amplifier-separated
- EX-L200
- HG-C

Useful functions

Teaching & window comparator mode

With an object below the sensor, press the TEACH key to set the valid range for distances via threshold values. There are 3 methods for setting the valid range: 1-point, 2-point, and 3-point teaching.

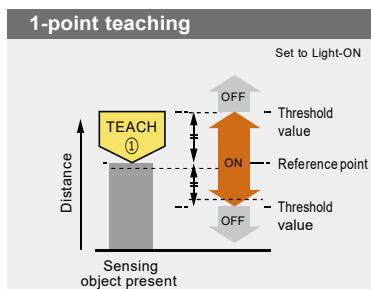

Perform 1-point teaching and the threshold range is set for the distance from the reference surface of the sensing object.

This is used for sensing within the threshold range.

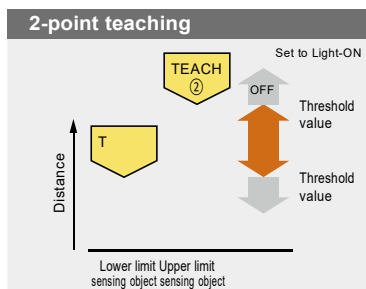

Press TEACH once for the lower (first point) and once for the upper limit (second point).

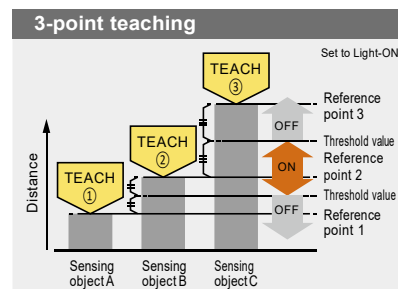

This is the method to set the threshold range by conducting the teaching at 3 points (sensing object A, B and C). After teaching, the reference points are automatically sorted in ascending order (reference point 1, 2 and 3). The thresholds are set at the midpoints between reference point 1 and 2, and 2 and 3, respectively.



In addition to the teaching & window comparator mode, the **“rising differential mode”**, **“trailing differential mode”** and **“normal sensing mode”** are available. In normal sensing mode, **“2-point teaching”** as basic teaching and **“limit teaching,”** which is useful for very small objects and backgrounds, are possible.

Timer setting function

The time mode options are “OFF-delay timer,” “ON-delay timer,” “One-shot timer” and “no timer.” The counting time is fixed to 5 ms.

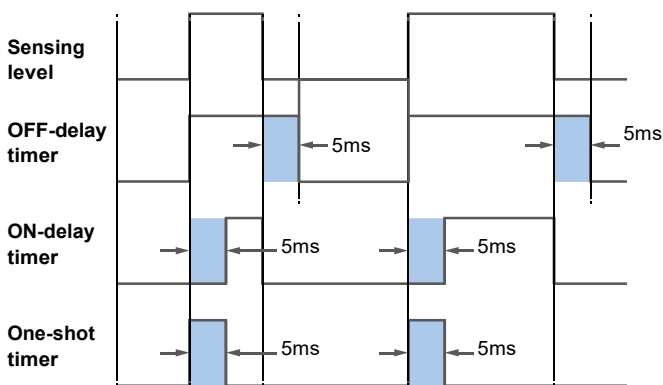

Timer period: 5 ms (fixed)

OFF-delay timer

Function: Extends output signals by 5 ms.

Usage: Appropriate in case a connected device is slow to respond and ON time is required to extend.

ON-delay timer

Function: Overrides output signals for 5 ms after detection.

Usage: Convenient way to override temporary signals and control with a time lag.

One-shot timer

Function: Sends output signals for only 5 ms after detection.

Usage: Useful when the signal duration needs to be constant to meet inputs from a connected device. This mode is also used to extend temporary signals by a desired length of time.

Zero set function

This function compulsorily sets the measured value to "zero." The zero point can be set at a desired value. It is useful when measuring steps or tolerance with reference to the height of a sensing object.



Keep pressing both keys for 3 seconds.

- * The zero set indicator (yellow) will turn ON while the zero set is valid.
- * When the zero set function is executed while the peak hold function or the bottom hold function is valid, the held measurement value is reset.
- * When the display setting is set to offset, the zero set function cannot be set.

External input setting function

One of four functions, "zero setting function," "teaching function," "emission stopping function" and "trigger function" can be assigned to an external input line.

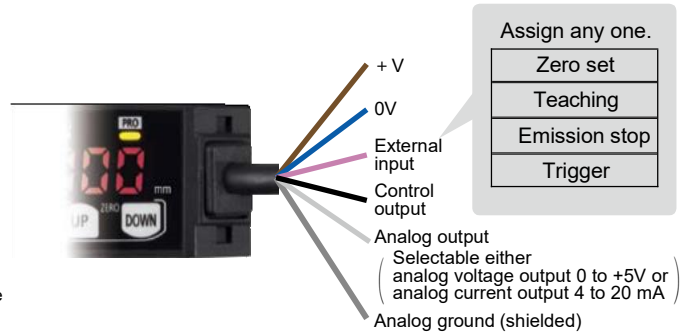

Display setting function

How to indicate measured values of the moving sensed object can be chosen from three options, "Normal," "Invert" and "Offset."

Example: HG-C1050(-P)

Display setting	Outside the measuring range		Measuring near point	Measurement center	Measuring far point	Outside the measuring range
	Normal	0.000 mm	0.000 mm	0.000 mm	0.000 mm	-15.00 mm
Invert	-0.000 mm	-0.000 mm	-15.00 mm	-0.000 mm	-0.000 mm	-0.000 mm
Offset	0.000 mm	0.000 mm	30.00 mm	0.000 mm	0.000 mm	0.000 mm

■ Relation between the setting display and the analog output (In case of analog voltage) output

(In case of analog current) output

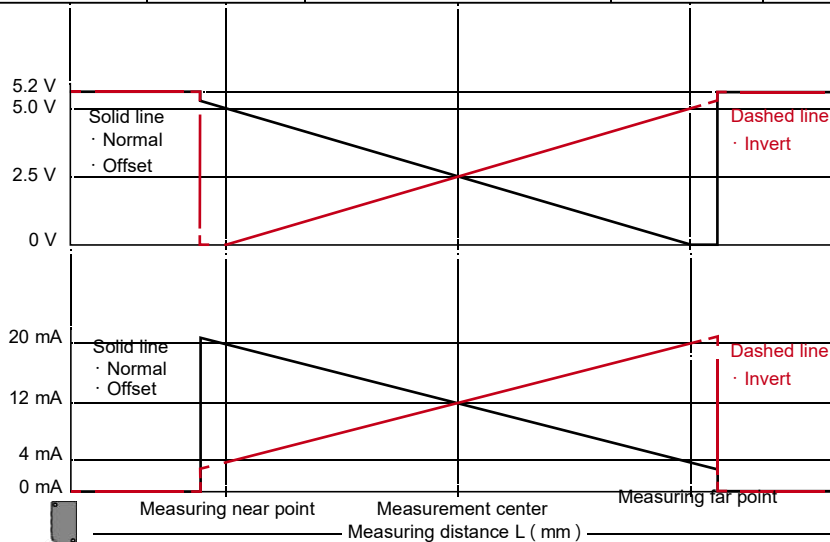

Peak and bottom hold functions

The peak hold function holds the maximum measured value which is output and displayed. The bottom hold function holds the minimum measured value which is output and displayed.

- * The peak hold function and the bottom hold function cannot be set at the same time.
- * When the zero set function is executed while the peak hold function or the bottom hold function is valid, the held measurement value is reset.

Threshold value fine adjustment function

Fine adjustment of threshold values can be performed while measurement is proceeding on the display, and even after teaching.

Key lock function

This function protects setting conditions from unintentional changes.

* For other functions and procedures for setting the functions, see "PRO Mode Setting" from p.196~.

FIBER SENSORS

LASER SENSORS

PHOTOELECTRIC SENSORS

MICRO PHOTOELECTRIC SENSORS

AREA SENSORS

SAFETY LIGHT CURTAINS / SAFETY COMPONENTS

PRESSURE / FLOW SENSORS

INDUCTIVE PROXIMITY SENSORS

PARTICULAR USE SENSORS

SENSOR OPTIONS

SIMPLE WIRE-SAVING UNITS

WIRE-SAVING SYSTEMS

MEASUREMENT SENSORS

STATIC CONTROL DEVICES

LASER MARKERS

PLC

HUMAN MACHINE INTERFACES

ENERGY MANAGEMENT SOLUTIONS

FA COMPONENTS

MACHINE VISION SYSTEMS

UV CURING SYSTEMS

Selection Guide

Amplifier Built-in

Amplifier-separated

EX-L200

HG-C

ORDER GUIDE

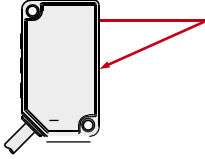
Type	Appearance	Measurement center distance and measurement range	Repeatability	Beam diameter (Note)	Model No.	
					NPN output	PNP output
Measurement center 30mm 1.181 in type		30 ± 5 mm 1.181 ± 0.197 in	10 μm 0.394 mil	ø50 μm 1.969 mil approx.	HG-C1030	HG-C1030-P
Measurement center 50mm 1.969 in type		50 ± 15 mm 1.969 ± 0.591 in	30 μm 1.181 mil	ø70 μm 2.756 mil approx.	HG-C1050	HG-C1050-P
Measurement center 100mm 3.937 in type		100 ± 35 mm 3.937 ± 1.328 in	70 μm 2.756 mil	ø120 μm 4.724 mil approx.	HG-C1100	HG-C1100-P
Measurement center 200mm 7.874 in type		200 ± 80 mm 7.874 ± 3.150 in	200 μm 7.874 mil	ø300 μm 11.811 mil approx.	HG-C1200	HG-C1200-P
Measurement center 400mm 15.748 in type		400 ± 200 mm 15.748 ± 7.874 in	300 μm 11.811 mil (Measuring distance 200 to 400 mm 7.874 to 15.748 in) 800 μm 31.496 mil (Measuring distance 400 to 600 mm 15.748 to 23.622 in)	ø500 μm 19.685 mil approx.	HG-C1400	HG-C1400-P

size in the measurement center distance. These values were defined by using 1/e² (13.5% approx.) of the center light intensity.
 Due to leak light outside the specified area, the reflectance around the detecting point may be higher than at the point and this may affect the measurement value.

OPTIONS

Designation	Model No.	Description
Simple mounting bracket (Note)	MS-HG-01	Foot angled mounting bracket

Note: Due to the simple mounting bracket, the sensing characteristics may not be hold depending on the installation condition, in case of the purposes for acquiring the displacement data and a fine detecting.

Simple mounting bracket

• **MS-HG-01**

Material: Stainless steel (SUS304)

Two M3 (length 25 mm 0.984 in) screws with washers (SPCC) are attached.

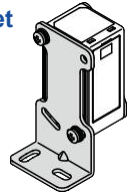

FIBER SENSORS

LASER SENSORS

PHOTO-ELECTRIC SENSORS

MICRO PHOTO-ELECTRIC SENSORS

AREA SENSORS SAFETY LIGHT CURTAIN SAFETY COMPONENTS

PRESSURE / FLOW SENSORS

INDUCTIVE PROXIMITY SENSORS

PARTICULAR USE SENSORS

SENSOR OPTIONS

SMILE WIRE-SAVING UNITS

WIRE-SAVING SYSTEMS

MEASURE-MENT SENSORS

STATIC CONTROL DEVICES

LASER MARKERS

PLC

HUMAN MACHINE INTERFACES

ENERGY MANAGEMENT SOLUTIONS

FA COMPONENTS

MACHINE VISION SYSTEMS

UV CURING SYSTEMS

Selection Guide

Amplifier Built-in

Amplifier-separated

EX-L200

HG-C

SPECIFICATIONS

Item	Model No.	Type	Measurement center 30mm type	Measurement center 50mm type	Measurement center 100mm type	Measurement center 200mm type	Measurement center 400mm type
		NPN output	HG-C1030	HG-C1050	HG-C1100	HG-C1200	HG-C1400
		PNP output	HG-C1030-P	HG-C1050-P	HG-C1100-P	HG-C1200-P	HG-C1400-P
CE marking directive compliance							
EMC Directive, RoHS Directive							
Measurement center distance			30 mm 1.181 in	50 mm 1.969 in	100 mm 3.937 in	200 mm 7.874 in	400 mm 15.748 in
Measurement range			±5 mm 0.197 in	±15 mm 0.591 in	±35 mm 1.328 in	±80 mm 3.150 in	±200 mm 7.874 in
Repeatability			10 μm 0.394 mil	30 μm 1.181 mil	70 μm 2.756 mil	200 μm 7.874 mil	300 μm 11.811 mil (Measuring distance 200 to 400 mm 7.874 to 15.748 in) 800 μm 31.496 mi (Measuring distance 400 to 600 mm 15.748 to 23.622 in)
Linearity			±0.1 % F.S.			±0.2 % F.S.	
Temperature characteristic	0.03 % F.S./°C						
Light source	Red semiconductor laser Class 2 [IEC / JIS / GB / FDA (Note 2)] Max. output: 1 mW, emission peak wavelength: 655 nm 0.026 mil						
Beam diameter (Note 3)			ø50 μm 1.969 mil approx.	ø70 μm 2.756 mil approx.	ø120 μm 4.724 mil approx.	ø300 μm 11.811 mil approx.	ø500 μm 19.685 mil approx.
Supply voltage	12 to 24 V DC ±10 %, Ripple P-P 10 % or less						
Power consumption	40 mA or less (at 24 V DC supply voltage), 65 mA or less (at 12 V DC supply voltage)						
Control output	<NPN output type> NPN open-collector transistor • Maximum sink current: 50 mA • Applied voltage: 30VDC or less (Between control output to 0V) • Residual voltage: 1.5 V or less (at 50 mA sink current) • Leakage current: 0.1 mA or less			<PNP output type> PNP open-collector transistor • Maximum source current: 50 mA • Applied voltage: 30VDC or less (Between control output to +V) • Residual voltage: 1.5 V or less (at 50 mA source current) • Leakage current: 0.1 mA or less			
Output operation	Switchable between either Light-ON or Dark-ON						
Short-circuit protection	Incorporated (auto reset type)						
Analog output	Analog voltage output • Output range: 0 to +5 V (at alarm: +5.2 V) • Output impedance: 100 Ω			Analog current output • Output range: 4 to 20 mA (at alarm: 0 mA) • Load impedance: 300 Ω or less			
Response time	Switchable between 1.5 ms / 5 ms / 10 ms						
External input	<NPN output type> NPN non-contact input • Input conditions Invalid: +8 V to +V DC or Open Valid: 0 to +1.2 V DC • Input impedance: 10 kΩ approx.			<PNP output type> PNP non-contact input • Input conditions Invalid: 0 to +0.6 V DC or Open Valid: +4 V to +V DC • Input impedance: 10 kΩ approx.			
Pollution degree	2						
Ambient altitude	2,000 m 6561.680 ft or less						
Environmental resistance	Protection	IP67 (IEC)					
	Ambient temperature	-10 to +45 °C -14 to 113 °F (No dew condensation or icing allowed), Storage: -20 to +60 °C -4 to 140 °F					
	Ambient humidity	35 to 85 % RH, Storage: 35 to 85 % RH					
	Ambient illuminance	Incandescent light: 3,000 lx or less at the light-receiving face					
	Vibration resistance	10 to 55 Hz (period: 1 min.) frequency, 1.5 mm 0.059 in double amplitude in X, Y and Z directions for two hours each					
Shock resistance	500 m/s ² acceleration (50 G approx.) in X, Y and Z directions three times each						
Cable	5-core composite cable, 2 m 6.5617 ft long						
Cable extension	Extension up to total 10 m 32.808 ft is possible with 0.3 mm ² , or more, cable.						
Material	Enclosure: Aluminum die-cast, Front cover: Acrylic						
Weight	Net weight: 35 g approx. (without cable), 85 g approx. (including cable)						

Notes: 1) Supply voltage: 24 V DC, ambient temperature: +20 °C **+68 °F**, response time: 10 ms, and analog output value of measurement center distance are used for unspecified measurement conditions. The subject is white ceramics.
 2) This product complies with 21 CFR 1040.10 and 1040.11 Laser Notice No. 50, dated June 24, 2007, issued by CDRH (Center for Devices and Radiological Health) under the FDA (Food and Drug Administration).
 3) This is the size in the measurement center distance. These values were defined by using 1/e² (13.5% approx.) of the center light intensity. Due to leak light outside the specified area, the reflectance around the detecting point may be higher than at the point and this may affect the measurement value.

FIBER SENSORS

LASER SENSORS

PHOTO-ELECTRIC SENSORS

MICRO PHOTO-ELECTRIC SENSORS

AREA SENSORS

SAFETY LIGHT CURTAINS / SAFETY COMPONENTS

PRESSURE / FLOW SENSORS

INDUCTIVE PROXIMITY SENSORS

PARTICULAR USE SENSORS

SENSOR OPTIONS

SIMPLE WIRE-SAVING UNITS

WIRE-SAVING SYSTEMS

MEASURE-MENT SENSORS

STATIC CONTROL DEVICES

LASER MARKERS

PLC

HUMAN MACHINE INTERFACES

ENERGY MANAGEMENT SOLUTIONS

FA COMPONENTS

MACHINE VISION SYSTEMS

UV CURING SYSTEMS

Selection Guide

Amplifier Built-in

Amplifier-separated

EX-L200

HG-C

FIBER SENSORS
 LASER SENSORS
 PHOTO-ELECTRIC SENSORS
 MICRO PHOTO-ELECTRIC SENSORS
 AREA SENSORS
 SAFETY LIGHT CURTAINS / SAFETY COMPONENTS
 PRESSURE / FLOW SENSORS
 INDUCTIVE PROXIMITY SENSORS
 PARTICULAR USE SENSORS
 SENSOR OPTIONS
 SIMPLE WIRE-SAVING UNITS
 WIRE-SAVING SYSTEMS
 MEASUREMENT SENSORS
 STATIC CONTROL DEVICES
 LASER MARKERS
 PLC
 HUMAN MACHINE INTERFACES
 ENERGY MANAGEMENT SOLUTIONS
 FA COMPONENTS
 MACHINE VISION SYSTEMS
 UV CURING SYSTEMS
 Selection Guide
 Amplifier Built-in
 Amplifier-separated
 EX-L200
 HG-C

I/O CIRCUIT DIAGRAMS

NPN output type

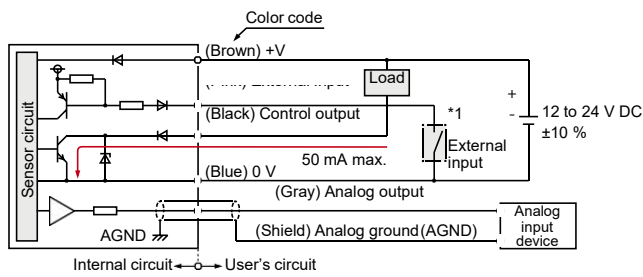

PNP output type

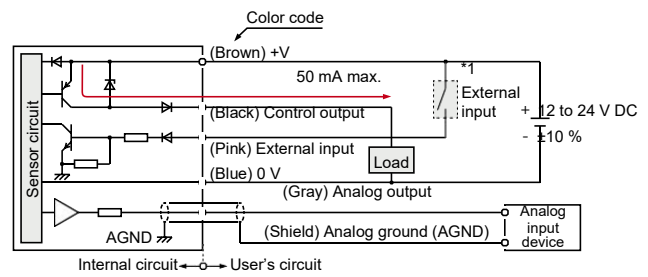

*1

Non-voltage contact or NPN open-collector transistor

- External input Invalid: +8 V to +V DC or open Valid: 0 to +1.2 V DC

*1

Non-voltage contact or PNP open-collector transistor

- External input Invalid: 0 to +0.6 V DC or open Valid: +4 V to +V DC

SENSING CHARACTERISTICS (TYPICAL)

Linearity

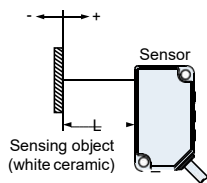

HG-C1030(-P)

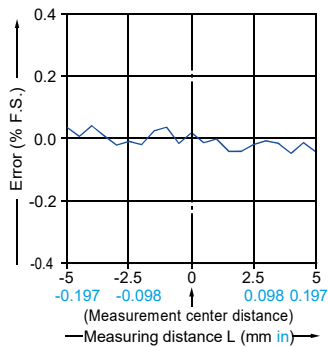

HG-C1050(-P)

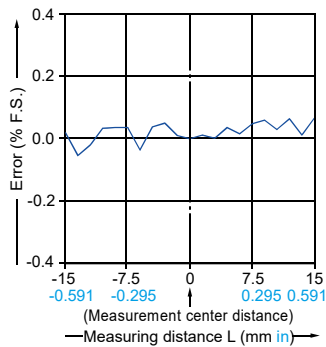

HG-C1100(-P)

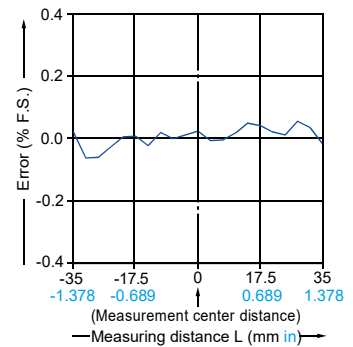

HG-C1200(-P)

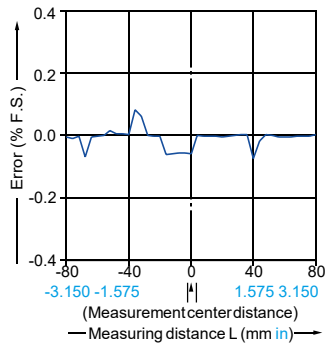

HG-C1400(-P)

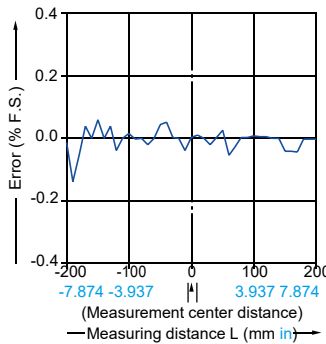

PRECAUTIONS FOR PROPER USE

Refer to p.1552~for general precautions and p.1593~for information about laser beam.

• This catalog is only provided to help choose a product and the user's guide attached to the product must be read before use.

• Never use this product as a sensing device for personnel protection.
 • In case of using sensing devices for personnel protection, use products which meet laws and standards, such as OSHA, ANSI or IEC etc., for personnel protection applicable in each region or country.

• Do not operate products using methods other than the ones described in the instruction manual included with each product. Control or adjustment through procedures other than the ones specified may cause hazardous laser radiation exposure.

• This product is classified as a Class 2 Laser Product under IEC / JIS / GB standards and FDA* regulations. Do not look at the laser beam directly or through an optical system such as a lens.
 • The warning label (English) is attached to the product. Handle the product according to the instruction given on the warning label. (The warning labels in Japanese and Chinese are packed with the sensor.)



* This product complies with 21 CFR 1040.10 and 1040.11 Laser Notice No. 50, dated June 24, 2007, issued by CDRH (Center for Devices and Radiological Health) under the FDA (Food and Drug Administration).

Part description

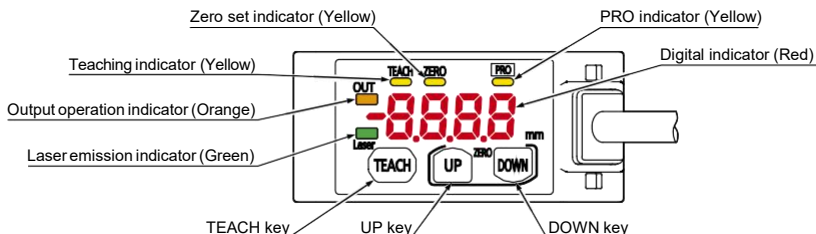

PRO mode setting

Part description

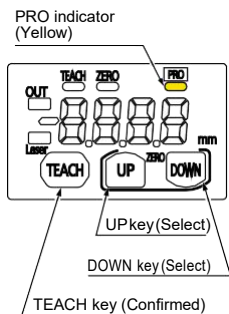

Item	Default setting	Description
Response time setting	Hr50	Set the response time. "Hr50": High precision 10ms, "Std": Standard 5ms, "Fast": High speed 1.5ms
Output operation setting	L-on	Select the control output operation mode. "L-on": Light-ON, "d-on": Dark-ON
Sensing output setting	-s-	Set the sensing output. "-s-": Normal sensing mode "-A-1": 1-point teaching (Window comparator mode) "-A-2 mode": 2-point teaching (Window comparator mode) "-A-3 mode": 3-point teaching (Window comparator mode) "d-": Rising differential mode "d-": Trailing differential mode
Analog output setting	vout	Set the output operation of analog output setting. "vout": Analog voltage output (0 to +5 V) "iout": Analog current output (4 to 20 mA)
Hysteresis setting	HG-C1030 0010 HG-C1050 003 HG-C1100 007 HG-C1200 02 HG-C1400 08	Set the hysteresis width. HG-C1030: 0.001 to 5.00 mm 0.00004 to 0.197 in HG-C1050: 0.01 to 15.00 mm 0.00039 to 0.591 in HG-C1100: 0.02 to 35.00 mm 0.00079 to 1.378 in HG-C1200: 0.1 to 80.0 mm 0.00394 to 3.150 in HG-C1400: 0.2 to 200.0 mm 0.00787 to 7.874 in
External input setting	0Set	Set the external input. "0Set": Zero set function, "Teach": Teaching function "Light": Light emitting stop function, "Trig": Trigger function
Timer setting	non	Set the timer operation. The timer time is fixed at 5ms. "non": No timer, "oFd": OFF-delay timer "ON": ON-delay timer, "o5d": One-shot timer
Display setting	Std	The display of the measured value can be changed. "Std": Normal, "Inv": Invert, "oFSt": Offset
Hold setting	oFF	Set the control output and the analogue output operation when a measurement error occurs (insufficient light intensity, saturation of light intensity, out of measurement range). "oFF": Hold OFF, "ON": Hold ON
ECO setting	oFF	The digital display can be set to go OFF when key operation is not performed for 30 seconds. Current consumption can be reduced. "oFF": ECO OFF, "ON": ECO ON
Reset setting	00	Return to the default setting (factory setting). "00": Reset NO, "oFF": Reset OK

FIBER SENSORS
 LASER SENSORS
 PHOTO-ELECTRIC SENSORS
 MICRO PHOTO-ELECTRIC SENSORS
 AREA SENSORS
 SAFETY LIGHT CURTAINS / SAFETY COMPONENTS
 PRESSURE / FLOW SENSORS
 INDUCTIVE PROXIMITY SENSORS
 PARTICULAR USE SENSORS
 SENSOR OPTIONS
 SIMPLE WIRE-SAVING UNITS
 WIRE-SAVING SYSTEMS
 MEASUREMENT SENSORS
 STATIC CONTROL DEVICES
 LASER MARKERS
 PLC
 HUMAN MACHINE INTERFACES
 ENERGY MANAGEMENT SOLUTIONS
 FA COMPONENTS
 MACHINE VISION SYSTEMS
 UV CURING SYSTEMS
 Selection Guide
 Amplifier Built-in
 Amplifier-separated
 EX-L200
 HG-C

PRECAUTIONS FOR PROPER USE

Refer to p.1552~ for general precautions and p.1593~ for information about laser beam.

Procedure

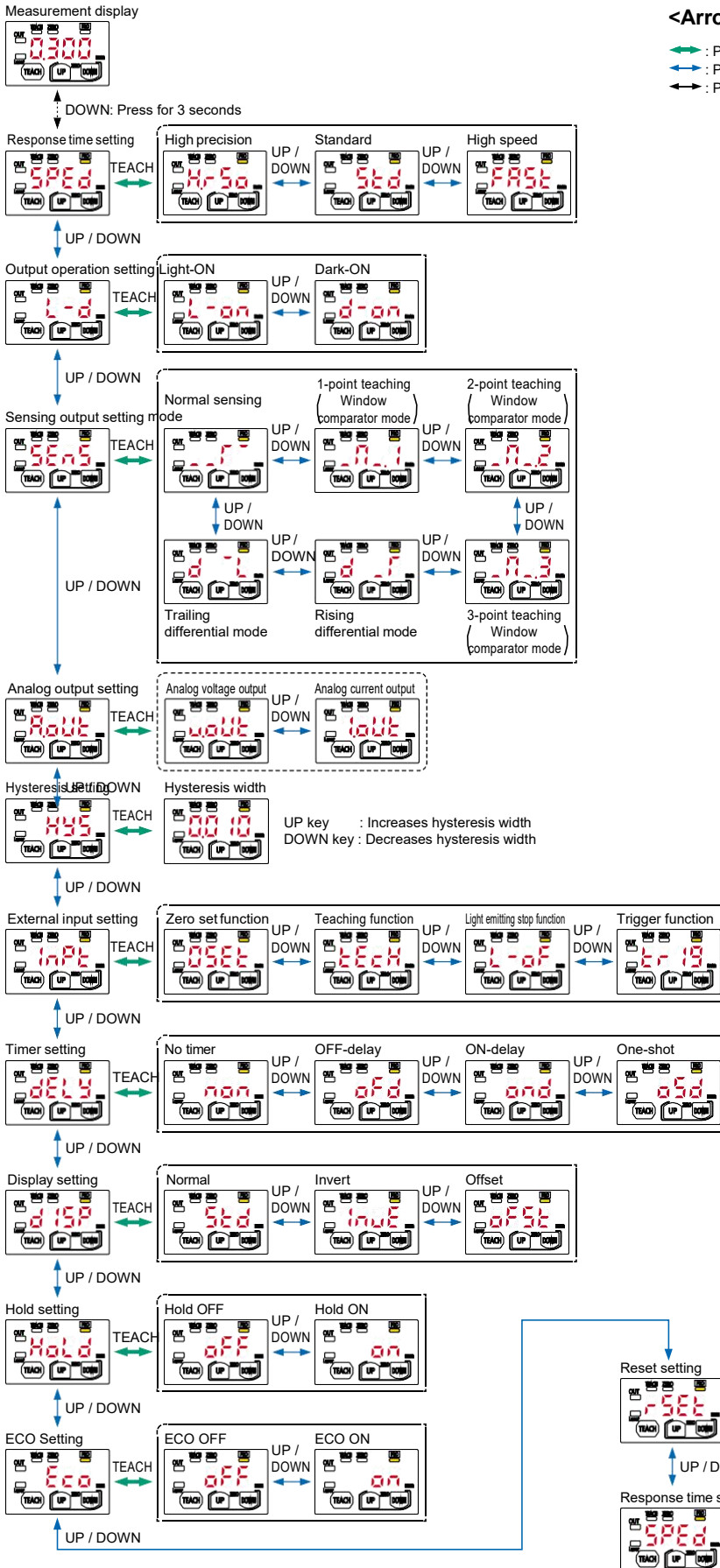

<Arrow description in figures>

- ↔ : Press the TEACH key
- ↑ : Press UP key or DOWN key
- ↓ : Press DOWN key

FIBER SENSORS
 LASER SENSORS
 PHOTO-ELECTRIC SENSORS
 MICRO PHOTO-ELECTRIC SENSORS
 AREA SENSORS
 SAFETY LIGHT CURTAINS / SAFETY COMPONENTS
 PRESSURE / FLOW SENSORS
 INDUCTIVE PROXIMITY SENSORS
 PARTICULAR USE SENSORS
 SENSOR OPTIONS
 SIMPLE WIRE-SAVING UNITS
 WIRE-SAVING SYSTEMS
 MEASUREMENT SENSORS
 STATIC CONTROL DEVICES
 LASER MARKERS
 PLC
 HUMAN MACHINE INTERFACES
 ENERGY MANAGEMENT SOLUTIONS
 FA COMPONENTS
 MACHINE VISION SYSTEMS
 UV CURING SYSTEMS
 Selection Guide
 Amplifier Built-in
 Amplifier-separated
 EX-L200
 HG-C

PRECAUTIONS FOR PROPER USE

Refer to p.1552~for general precautions and p.1593~for information about laser beam.

Mounting

- When mounting this product, use M3 screws. The tightening torque should be 0.5 N·m. Please prepare M3 screws separately.

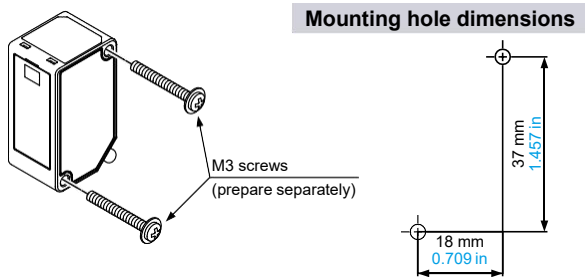

- When mounting the simple mounting bracket (optional) on this product, the tightening torque should be 0.5 N m or less.

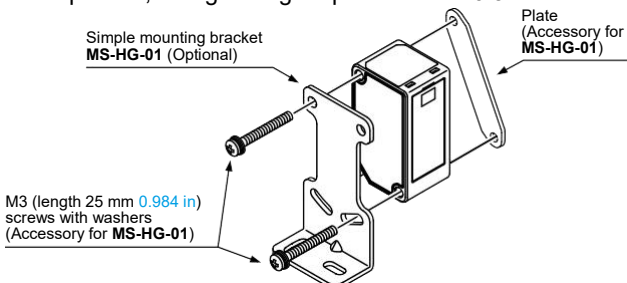

Note: Due to the simple mounting bracket, the sensing characteristics may not be hold depending on the installation condition, in case of the purposes for acquiring the displacement data and a fine detecting.

Mounting direction

- **Direction to a movable body**
<When there are differences in material and color>
- When performing measurements of moving objects with excessively different materials and colors, mount the product per the following directions to minimize measurement errors.

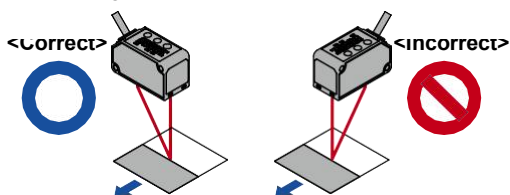

<Measurement of rotating objects>

- When measuring rotating objects, mount the product as follows. Measurement can be performed with minimized effect on the object caused by up / down deflection, position deviation and etc.

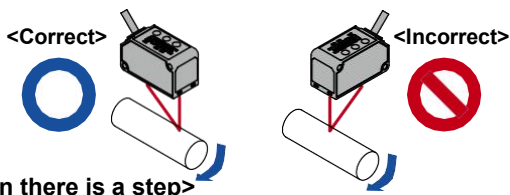

<When there is a step>

- When there is a step in the moving object, mount the product as follows. Measurement can be performed with minimized effect from the edges of the steps.

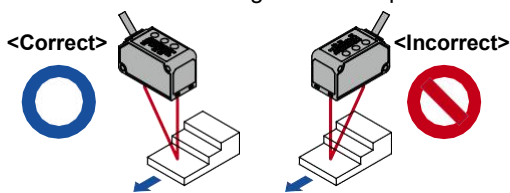

Measuring of narrow locations and recesses

- When measuring in narrow locations or inside holes, mount the product so that optical path from the light-emitting part to light-receiving part is not interrupted.

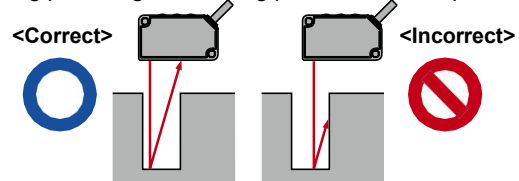

When mounting the product on a wall

- Mount the product as follows, so that the multiple light reflections on the wall do not emit to the light-receiving part. When the reflection factor on a wall is high, it is effective to use a dull black color.

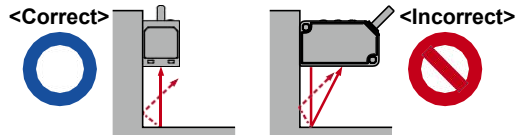

Others

- This product has been developed / produced for industrial use only.
- Make sure that the power supply is OFF before starting the wiring.
- If the wiring is performed incorrectly, it will cause a failure.
- Do not run the wires together with high-voltage lines or power lines, or put them in the same raceway. This can cause malfunction due to induction.
- Verify that the supply voltage variation is within the rating.
- If power is supplied from a commercial switching regulator, ensure that the frame ground (F.G.) terminal of the power supply is connected to an actual ground.
- If noise generating devices (switching regulators, inverter motors, etc.) are used around the sensor mounting area, make sure to connect the frame ground (F.G.) terminal of the device.
- Do not use this product during the transient state when the power supply is turned ON.
- Extension up to total 10 m 32.808 ft is possible with 0.3 mm², or more, cable.
- Make sure that stress by forcible bend or pulling is not applied to the sensor cable joint.
- Take care that the sensor is not directly exposed to fluorescent lamp from a rapid-starter lamp or a high frequency lighting device, as it may affect the sensing performance.
- This product is suitable for indoor use only.
- Keep water, oil, fingerprints and etc. which reflect light, or dust, particles or etc. which interrupts the light, away from the emitting/receiving surfaces of this product. If contaminants adhere to the surface, wipe off with a dust-free soft cloth, or lens cleaning paper.
- Do not use the sensor in locations where there is excessive vapor, dust or etc. or in an atmosphere where corrosive gases, etc. is generated.
- Take care that the product does not come in contact with oil, grease, organic solvents such as thinner, etc., strong acid or alkaline.
- Make sure to turn OFF the power supply, before cleaning the light emitting/receiving windows of the sensor head.
- There is a certain deviation in the directionality of this product. Install the product using a mounting bracket or similar fitting to allow the adjustment of optical axis.
- The internal memory (nonvolatile) of this product has a service life. Settings cannot be configured more than 100,000 times.

FIBER SENSORS

LASER SENSORS

PHOTO-ELECTRIC SENSORS

MICRO PHOTO-ELECTRIC SENSORS

AREA SENSORS

SAFETY LIGHT CURTAINS / SAFETY COMPONENTS

PRESSURE / FLOW SENSORS

INDUCTIVE PROXIMITY SENSORS

PARTICULAR USE SENSORS

SENSOR OPTIONS

SIMPLE WIRE-SAVING UNITS

WIRE-SAVING SYSTEMS

MEASUREMENT SENSORS

STATIC CONTROL DEVICES

LASER MARKERS

PLC

HUMAN MACHINE INTERFACES

ENERGY MANAGEMENT SOLUTIONS

FA COMPONENTS

MACHINE VISION SYSTEMS

UV CURING SYSTEMS

Selection Guide

Amplifier Built-in

Amplifier-separated

EX-L200

HG-C

PRECAUTIONS FOR PROPER USE

Refer to p.1552~ for general precautions and p.1593~ for information about laser beam.

Error indication

- In case of errors, attempt the following measures.

Error indication	Description	Remedy
<Hold OFF> ----- <Hold ON> Measured value blinks	Insufficient amount of reflected light. The sensing object is out of the sensing range.	Confirm that the sensing distance is within the specification range. Adjust the installation angle of the sensor.
E-01	Flash memory is damaged or is past its life expectancy.	Please contact our office.
E-11	Load of the sensing output is short-circuited causing an over-current to flow.	Turn OFF the power and check the load.
E-21	The semiconductor laser is damaged or is past its life expectancy.	Please contact our office.
E-31	<ul style="list-style-type: none"> • When zero set is set, the measurement is not performed normally. • Since the display setting is set to "Offset", the zero set function can not be used. 	<ul style="list-style-type: none"> • Confirm that the sensing distance is within the specification range. • Set the display to any setting except "Offset."
E-41	During teaching, the measurement is not performed normally.	Confirm that the sensing distance is within the specification range.
E-90 E-91 E-92 E-93	System error	Please contact our office.

DIMENSIONS (Unit: mm in)

The CAD data can be downloaded from our website.

HG-C

Sensor

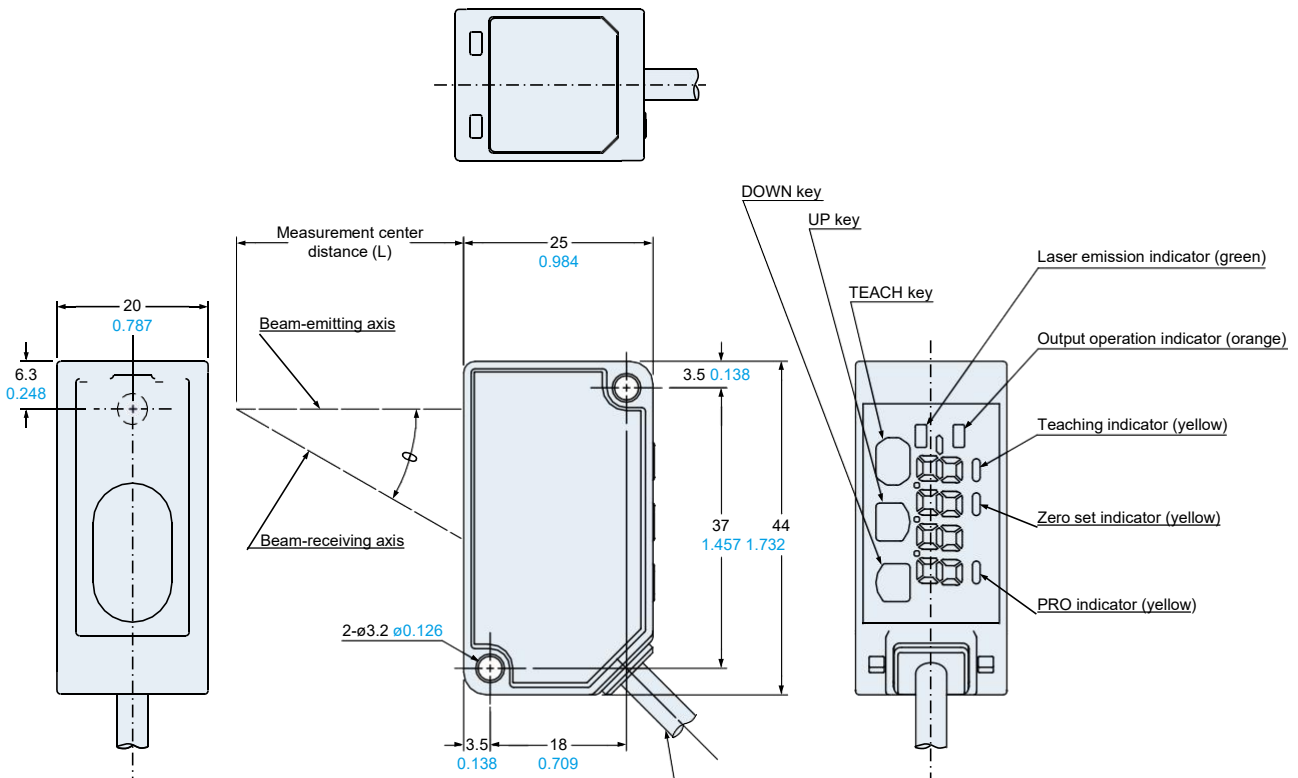

Model No.	Measurement center distance (L)	θ
HG-C1030(-P)	30 1.181	30°
HG-C1050(-P)	50 1.969	22.5°
HG-C1100(-P)	100 3.937	12.5°
HG-C1200(-P)	200 7.874	6.3°
HG-C1400(-P)	400 15.748	3.2°

FIBER SENSORS
LASER SENSORS
PHOTO-ELECTRIC SENSORS
MICRO PHOTO-ELECTRIC SENSORS
AREA SENSORS
SAFETY LIGHT CURTAINS / SAFETY COMPONENTS
PRESSURE / FLOW SENSORS
INDUCTIVE PROXIMITY SENSORS
PARTICULAR USE SENSORS
SENSOR OPTIONS
SIMPLE WIRE-SAVING UNITS
WIRE-SAVING SYSTEMS
MEASUREMENT SENSORS
STATIC CONTROL DEVICES
LASER MARKERS
PLC
HUMAN MACHINE INTERFACES
ENERGY MANAGEMENT SOLUTIONS
FA COMPONENTS
MACHINE VISION SYSTEMS
UV CURING SYSTEMS

Selection Guide
Amplifier Built-in
Amplifier-separated
EX-L200
HG-C

DIMENSIONS (Unit: mm in)

The CAD data can be downloaded from our website. **FIBER SENSORS**

MS-HG-01

Simple mounting bracket (Optional)

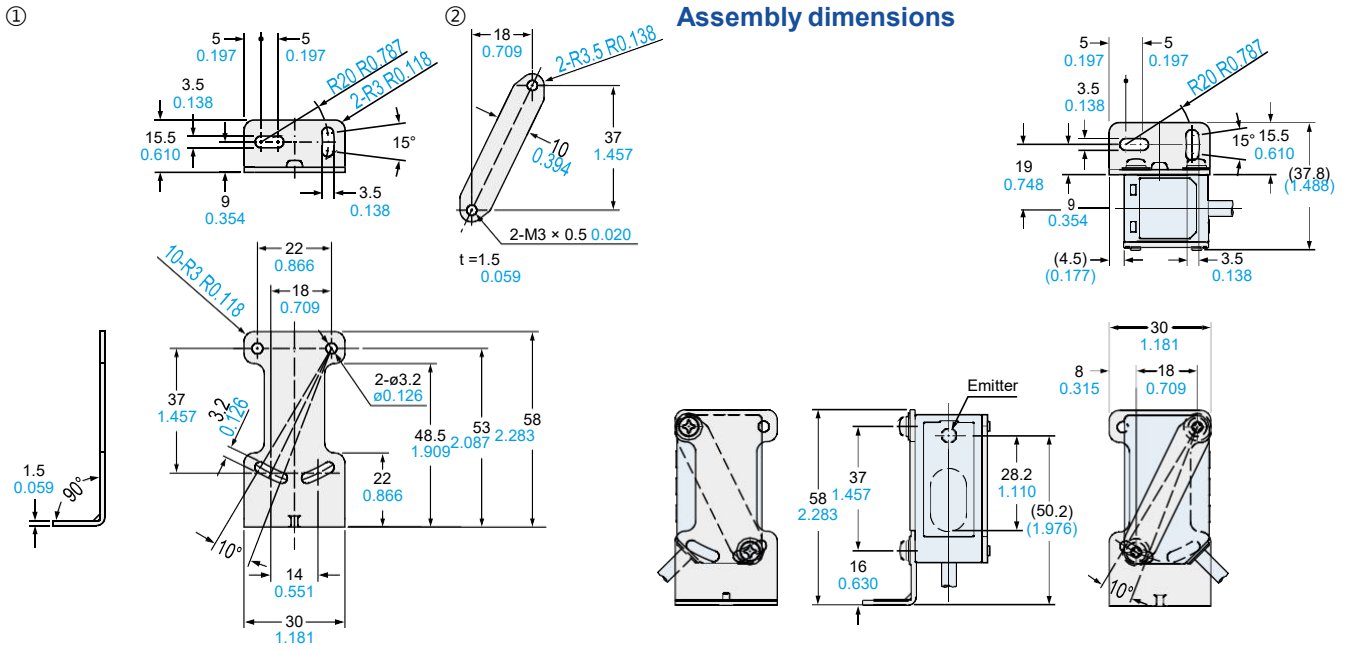

LASER SENSORS

PHOTO-ELECTRIC SENSORS

MICRO PHOTO-ELECTRIC SENSORS

AREA SENSORS

SAFETY LIGHT CURTAINS / SAFETY COMPONENTS

PRESSURE / FLOW SENSORS

INDUCTIVE PROXIMITY SENSORS

PARTICULAR USE SENSORS

SENSOR OPTIONS

SIMPLE WIRE-SAVING UNITS

WIRE-SAVING SYSTEMS

MEASUREMENT SENSORS

STATIC CONTROL DEVICES

LASER MARKERS

PLC

HUMAN MACHINE INTERFACES

ENERGY MANAGEMENT SOLUTIONS

FA COMPONENTS

MACHINE VISION SYSTEMS

UV CURING SYSTEMS

Selection Guide

Amplifier Built-in

Amplifier-separated

EX-L200

HG-C