

For Various Analog I/Os

- Analog Input Units for converting analog input signals into binary data
- Analog Output Units for converting binary data into analog output signals



CS1W-MAD44



CS1W-DA08V



CS1W-AD081-V1

Features

Analog Input Unit:

- Holds a maximum of 16 analog input signals in 1 unit.
- Reduces wiring using MIL connector (CS1W-AD161)
- Connector-Terminal Block Conversion Unit and Connecting Cable available for CS1W-AD161
- With functions including line disconnection detection, peak value holding, as well as mean value processing
- Scaling function (CS1W-AD161 only)

Analog Output Unit:

- Outputs a maximum of 8 analog output signals in 1 unit.
- Output hold function

Analog I/O Unit:

- Has both analog input and output signals
- Ratio conversion function stores the results of positive and negative gradient analog inputs calculated for ratio and bias as analog output values
- Hold a maximum of 4 analog input signals and outputs 4 analog output signals in 1 unit

Analog Input functions - Peak value holding, mean value processing and line disconnection detection

Analog Output functions - Output hold function

System Configuration

CS-series PLCs

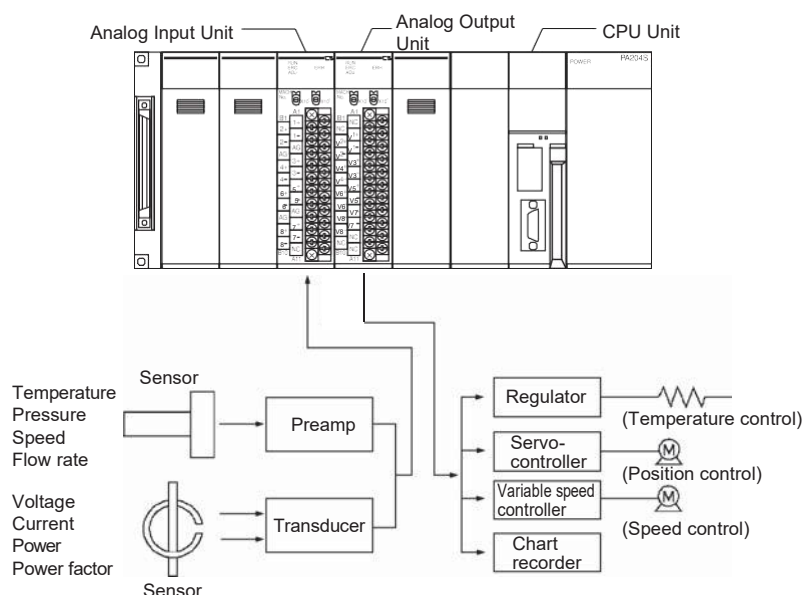

Note: The above diagram is an installation example for the CS1W-AD081-V1 Analog Input Unit and CS1W-DA08V Analog Output Unit.

Ordering Information

Applicable standards

Refer to the OMRON website (www.ia.omron.com) or ask your OMRON representative for the most recent applicable standards for each model.

Analog Input Units

Unit type	Product name	Specifications						Model	No. of Unit numbers allocated	Current consumption (A)	
		I/O points	Signal range selection	Signal range	Resolution	Conversion speed	External connection			5V	26V
CS-series Special I/O Units	Analog Input Units	4 inputs	Set separately for each input	1 to 5 V, 0 to 5 V, 0 to 10 V, -10 V to 10 V, 4 to 20 mA	1/8,000 (Settable to 1/4,000)	250 s/point max. (Settable to 1 ms/point)	Removable terminal block	CS1W-AD041-V1	1	0.12	0.09
		8 inputs		1 to 5 V, 0 to 5 V, 0 to 10 V, -10 V to 10 V, 4 to 20 mA	1/8,000 (Settable to 1/4,000)	250 s/point max. (Settable to 1 ms/point)		CS1W-AD081-V1			
		16 inputs				MIL connector		CS1W-AD161			
	CS1W-AD161 Connector-Terminal block conversion Units	Slim-type terminal block 34 terminal, dimensions: 128 × 40 × 39 mm						XW2D-34G6		-	
		Connecting cable Length: 2 m						XW2Z-200C		-	

Analog Output Units

Unit type	Product name	Specifications						Model	No. of Unit numbers allocated	Current consumption (A)	
		I/O points	Signal range selection	Signal range	Resolution	Conversion speed	External connection			5V	26V
CS1 Special analog I/O Units	Analog Output Units	4 outputs	Set separately for each input	1 to 5 V, 0 to 5 V, 0 to 10 V, -10 V to 10 V, 4 to 20 mA	1/4,000	1 ms/point	Removable terminal block	CS1W-DA041	1	0.13	0.18
		8 outputs		1 to 5 V, 0 to 5 V, 0 to 10 V, -10 V to 10 V	1/4,000	1 ms/point		CS1W-DA08V			
		8 outputs		4 to 20 mA	1/4,000	1 ms/point		CS1W-DA08C			

Analog I/O Units

Unit type	Product name	Specifications						Model	No. of Unit numbers allocated	Current consumption (A)	
		I/O points	Signal range selection	Signal range	Resolution	Conversion speed	External connection			5V	26V
CS1 Special analog I/O Units	Analog I/O Units	4 inputs	Set separately for each input	1 to 5 V, 0 to 5 V, 0 to 10 V, -10 V to 10 V, 4 to 20 mA	1/4,000	1 ms/point	Removable terminal block	CS1W-MAD44	1	0.20	0.20
	4 outputs	1 to 5 V, 0 to 5 V, 0 to 10 V, -10 V to 10 V		1/4,000	1 ms/point						

Individual Specifications

Analog Input Units CS1W-AD041-V1/AD081-V1/AD161

Specifications

Item		CS1W-AD041-V1	CS1W-AD081-V1	CS1W-AD161	
Applicable PLC model		CS series			
Unit type		CS1 Special I/O Unit			
Isolation *1		Between I/O and PLC signals: Photocoupler (No isolation between individual I/O signals.)			
External terminals		21-point detachable terminal block (M3 screws)	Two 34-pin MIL connectors		
Affect on CPU Unit cycle time		0.2 ms			
Power consumption		120 mA max. at 5 VDC, 90 mA max. at 26 VDC		150 mA max. at 5 VDC, 55 mA max. at 26 VDC	
Dimensions (mm) *2		35 × 130 × 126 (W × H × D)		35 × 130 × 119 (W × H × D)	
Weight		450 g max.			
General specifications		Conforms to general specifications for SYSMAC CS Series.			
Mounting position		CS-series CPU Rack or CS-series Expansion Rack (Cannot be mounted to a C200H Expansion I/O Rack or a SYSMAC BUS Slave Rack.)			
Maximum number of Units		Depends on the power supply Unit. *3			
Data exchange with CPU Units *4		Special I/O Unit Area in CIO Area (CIO 2000 to CIO 2959): 10 words per Unit Special I/O Unit Area in DM Area (D20000 to D29599): 100 words per Unit		Special I/O Unit Area in CIO Area (CIO 2000 to CIO 2959): 20 words per Unit Special I/O Unit Area in DM Area (D20000 to D29599): 200 words per Unit	
Input specifications	Number of analog inputs	4	8	16	
	Input signal range *5	1 to 5 V 0 to 5 V 0 to 10 V -10 to 10 V 4 to 20 mA *6			
	Maximum rated input (for 1 point) *7	Voltage Input: ±15 V Current Input: ±30 mA			
	Input impedance	Voltage Input: 1 M Ω min. Current Input: 250 Ω (rated value)			
	Resolution	4,000/8,000 *8			
	Converted output data	16-bit binary data			
	Accuracy *9	23±2°C	Voltage Input: ±0.2% of full scale Current Input: ±0.4% of full scale		Voltage Input: ±0.2% of full scale Current Input: ±0.2% of full scale
		0°C to 55°C	Voltage Input: ±0.4% of full scale Current Input: ±0.6% of full scale		Voltage Input: ±0.4% of full scale Current Input: ±0.4% of full scale
	A/D conversion time *10	1.0 ms or 250 μ s per point max. *8			
	Mean value processing	Stores the last "n" data conversions in the buffer, and stores the mean value of the conversion values. Buffer number: n = 2, 4, 8, 16, 32, 64			
	Peak value holding	Stores the maximum conversion value while the Peak Value Hold Bit is ON.			
	Input disconnection detection	Detects the disconnection and turns ON the Disconnection Detection Flag. *11			
Scaling function	None	None	Enabled only for conversion time of 1 ms and resolution of 4,000. Setting any values within a range of ±32,000 as the upper and lower limits allows the A/D conversion result to be output with these values as full scale.		

*1. Do not apply a voltage higher than 600 V to the terminal block when performing withstand voltage test on this Unit. Otherwise, internal elements may deteriorate.

*2. Refer to *Dimensions* on page 20 for details on the Unit's dimensions.

*3. The maximum number of Analog Input Units that can be mounted to one Rack depends on the Power Supply Unit mounted to the Rack.

Power Supply Unit	Rack	CS1W-AD041-V1 CS1W-AD081-V1 (5 VDC 120 mA)	CS1W-DA041 CS1W-DA08V (5 VDC 130 mA)	CS1W-MAD44 (5 VDC 200 mA)	CS1W-DA08C (5 VDC 130 mA)	CS1W-AD161 (5 VDC 150 mA)
C200HW-PA204 C200HW-PA204S C200HW-PA204R C200HW-PA204C C200HW-PD024 (4.6 A at 5 VDC)	CPU Rack	6	3	3	2	8
	Expansion Rack	6	3	3	2	9
C200HW-PA209R (9 A at 5 VDC)	CPU Rack	10	7	6	5	10
	Expansion Rack	10	7	6	5	10
CS1D-PA207R (7 A at 5 VDC)	CPU Rack	8	5	4	4	8
	Expansion Rack	9	6	5	4	9
CS1D-PD024 (4.3 A at 5 VDC)	CPU Rack	6	3	2	2	7
	Expansion Rack	6	3	2	2	8

The above limits may be reduced depending on the power consumed by other Units on the same Rack.

***4. Data Exchange with the CPU Unit**

Area	Number of words	Data transfer timing	Transfer direction	Data contents
Special I/O Unit Area in CIO Area (CIO 2000 to CIO 2959, CIO 2000.00 to CIO 2959.15)	<ul style="list-style-type: none"> CS1W-AD041-V1/081-V1: 10 words per Unit CS1W-AD161: 20 words per Unit 	Constantly	CPU Unit to Analog Input Unit	Peak hold indicators
			Analog Input Unit to CPU Unit	Analog input values Line disconnection detection Alarm flags Etc.
Special I/O Unit Area in DM Area (D20000 to D26959)	<ul style="list-style-type: none"> CS1W-AD041-V1/081-V1: 100 words per Unit CS1W-AD161: 200 words per Unit 	When power is turned ON or Unit is restarted	CPU Unit to Analog Input Unit	Input signal conversion ON/OFF Signal range specifications Averaging specifications Resolution/conversion time setting Operation mode setting Scaling setting (CS1W-AD161 only)

The resolution/conversion time setting and operation mode setting are supported only by version-1 Analog Input Units.

- *5. Input signal ranges can be set for each input.
- *6. Voltage input or current input is selected for the CS1W-AD041-V1 and CS1W-AD081-V1 by using the voltage/current switch at the back of the terminal block. Voltage input or current input is selected for the CS1W-AD161 by wiring the connector terminals. Voltage/current selection for input ranges 1 to 5 V or 4 to 20 mA can be set in DM word m+52.
- *7. Use the analog input voltage/current value within the specified input signal range. Exceeding the specified range may result in malfunction.
- *8. With Analog Input Units, the resolution can be changed from 4,000 to 8,000 and the conversion time changed from 1 ms to 250 μs in DM word m+18 for CS1W-AD041-V1 and CS1W-AD081-V1 or in DM word m+19 for CS1W-AD161.
- *9. The following are adjusted at the factory.
 CS1W-AD041-V1/081-V1: Voltage inputs
 CS1W-AD161: Voltage inputs and current inputs
 Calibration conditions: Recommended Terminal Block-Connector Conversion Unit used. (The factory calibration for a current input can be made effective by setting DM word m+52.)
 To use current inputs with the CS1W-AD041-V1/081-V1 or to use the CS1W-AD161 with products other than the recommended ones, adjust the offset and gain as required.
- *10. A/D conversion time is the time it takes for an analog signal to be stored in memory as converted data after it has been input. It takes at least one cycle before the converted data is read by the CPU Unit.
- *11. Input disconnection detection is valid only when the 1 to 5-V or 4 to 20-mA range is set. If there is no input signal for when the 1 to 5-V or 4 to 20-mA range is set, the Disconnection Detection Flag will turn ON.

Input Function Block Diagram

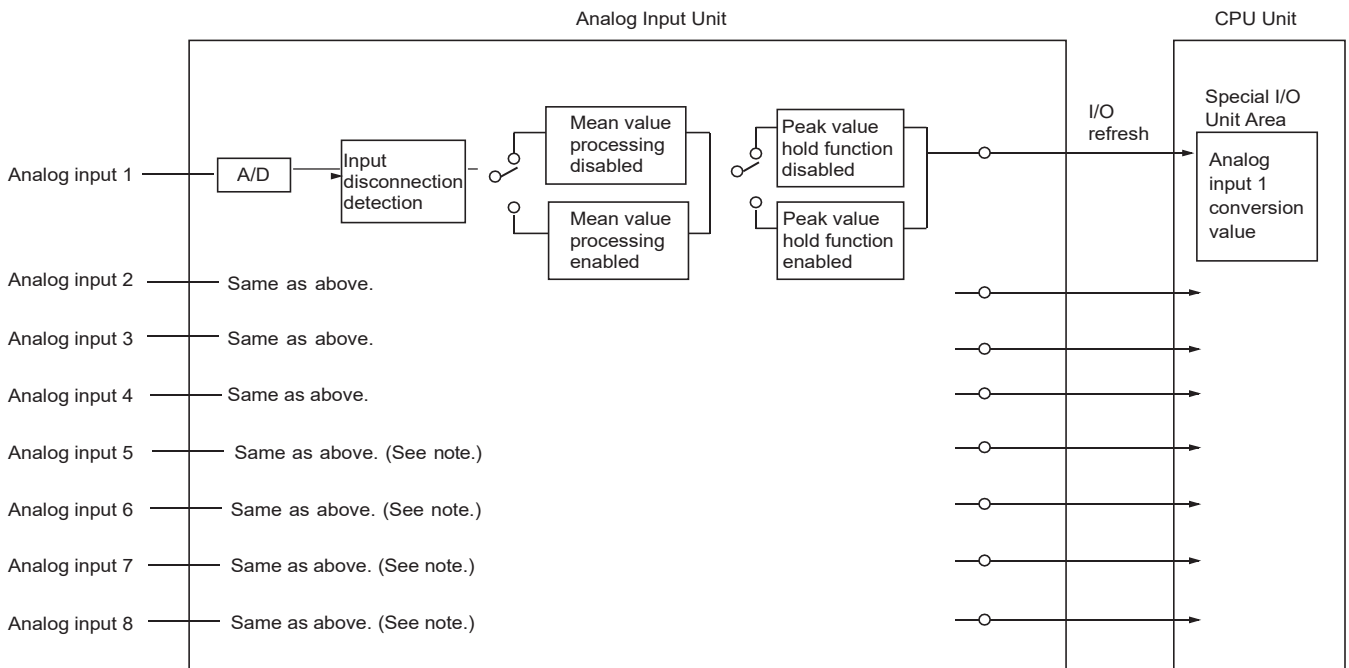

Note: There are only four analog inputs for the CS1W-AD041-V1, and 16 analog inputs for the CS1W-AD161.

External Interface

CS1W-AD041-V1
CS1W-AD081-V1

Front

With Terminal Block

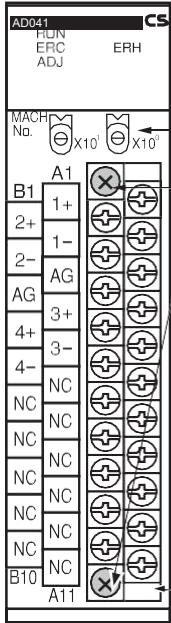

With Terminal Block Removed

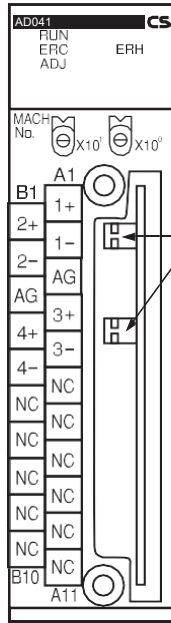

With Terminal Block

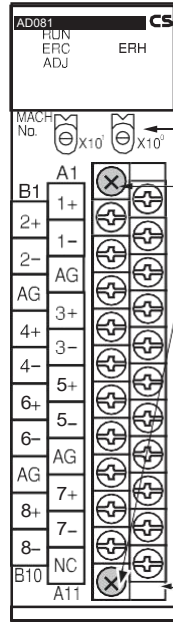

With Terminal Block Removed

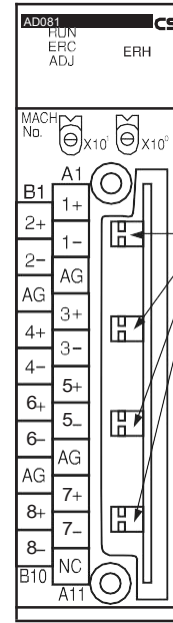

Back

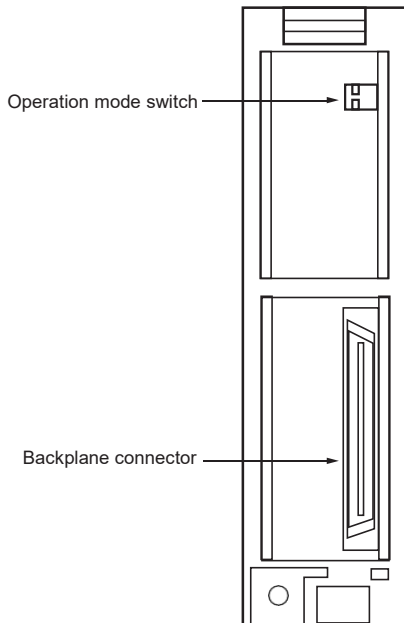

Side

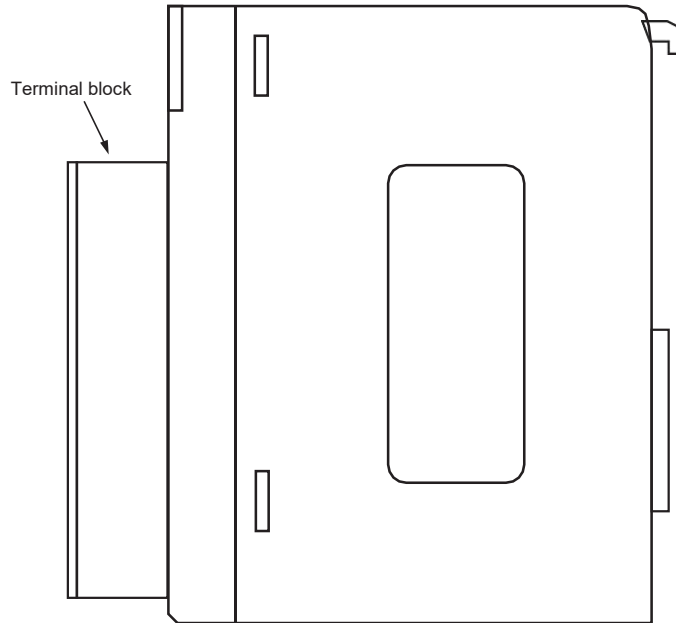

The terminal block is attached by a connector. It can be removed by loosening the two black mounting screws located at the top and bottom of the terminal block.

Check to be sure that the black terminal block mounting screw is securely tightened to a torque of 0.5 N·m.

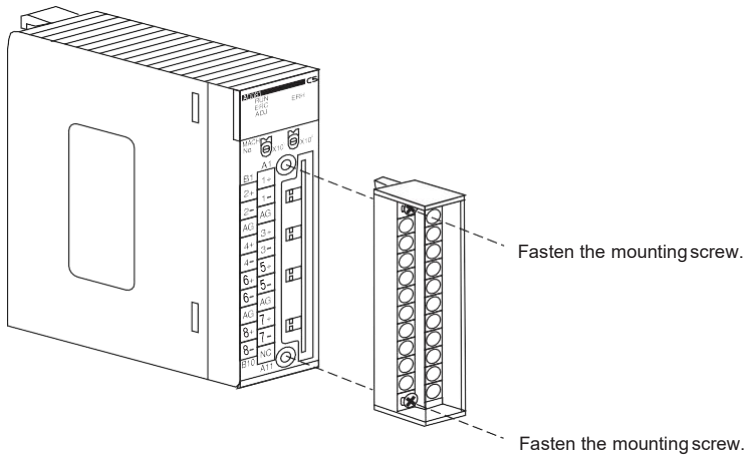

CS1W-AD161

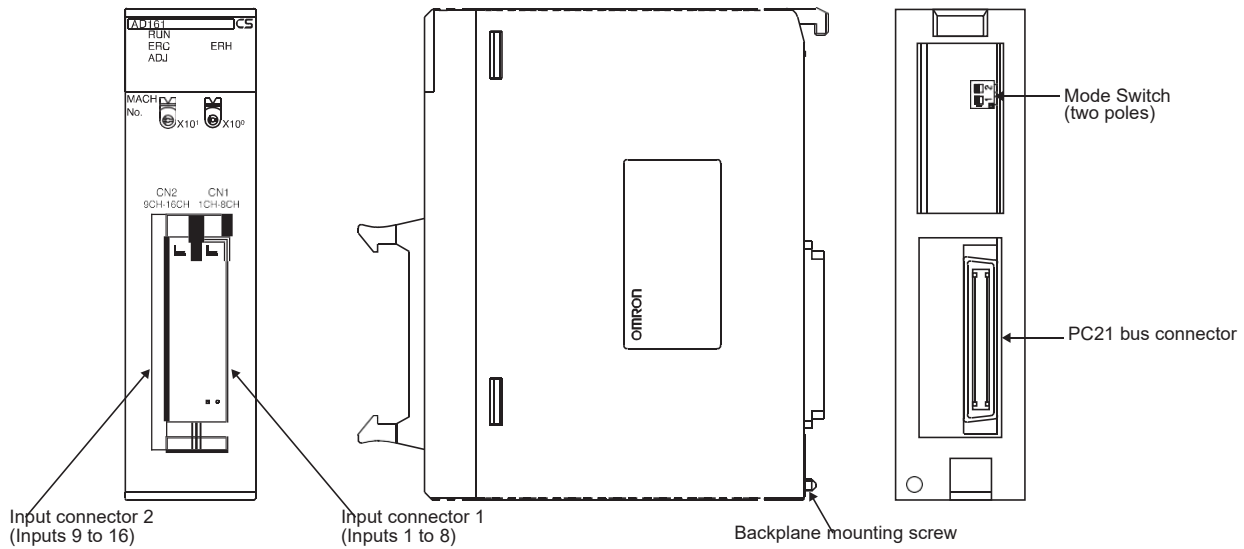

Indicators

The indicators show the operating status of the Unit. The following table shows the meanings of the indicators.

LED	Meaning	Indicator	Operating status
RUN (green)	Operating	Lit	Operating in normal mode.
		Not lit	Unit has stopped exchanging data with the CPU Unit.
ERC (red)	Error detected by Unit	Lit	Alarm has occurred (such as disconnection detection) or initial settings are incorrect.
		Not lit	Operating normally.
ADJ (yellow)	Adjusting	Flashing	Operating in offset/gain adjustment mode.
		Not lit	Other than the above.
ERH (red)	Error in the CPU Unit	Lit	Error has occurred during data exchange with the CPU Unit.
		Not lit	Operating normally.

Internal Circuitry

The following diagrams show the internal circuitry of the analog input section.

Input Circuitry

CS1W-AD041-V1/AD081-V1

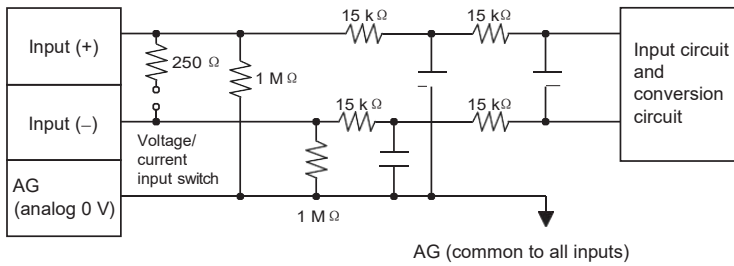

CS1W-AD161

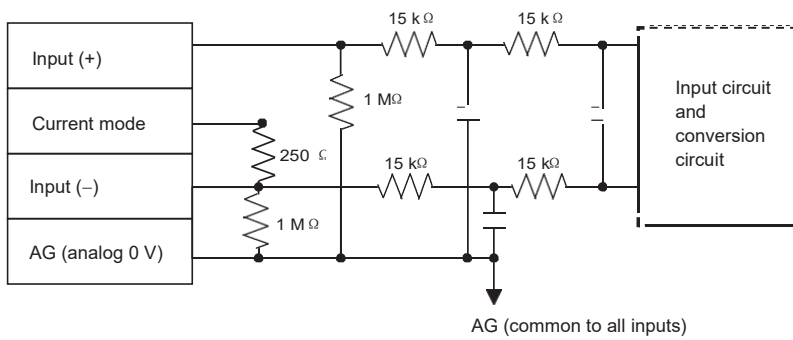

Internal Configuration

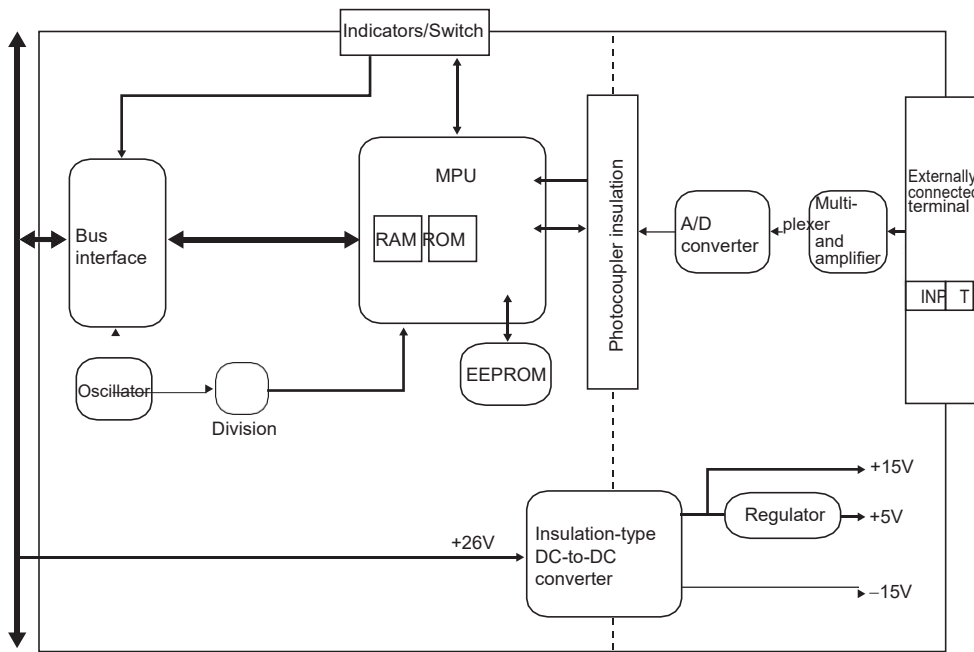

CS-series PC

Terminal Arrangement

The signal names corresponding to the connecting terminals are as shown in the following diagram.

CS1W-AD041-V1

Input 2+	B1	A1	Input 1+
Input 2-	B2	A2	Input 1-
AG	B3	A3	AG
Input 4+	B4	A4	Input 3+
Input 4-	B5	A5	Input 3-
N.C.	B6	A6	N.C.
N.C.	B7	A7	N.C.
N.C.	B8	A8	N.C.
N.C.	B9	A9	N.C.
N.C.	B10	A10	N.C.
		A11	N.C.

CS1W-AD081-V1

Input 2+	B1	A1	Input 1+
Input 2-	B2	A2	Input 1-
AG	B3	A3	AG
Input 4+	B4	A4	Input 3+
Input 4-	B5	A5	Input 3-
Input 6+	B6	A6	Input 5+
Input 6-	B7	A7	Input 5-
AG	B8	A8	AG
Input 8+	B9	A9	Input 7+
Input 8-	B10	A10	Input 7-
		A11	N.C.

CS1W-AD161

CN2 Inputs 9 to 16

Input 9+	1	2	Input 10+
Current mode 9	3	4	Current mode 10
Input 9-	5	6	Input 10-
AG	7	8	AG
Input 11+	9	10	Input 12+
Current mode 11	11	12	Current mode 12
Input 11-	13	14	Input 12-
AG	15	16	AG
Input 13+	17	18	Input 14+
Current mode 13	19	20	Current mode 14
Input 13-	21	22	Input 14-
AG	23	24	AG
Input 15+	25	26	Input 16+
Current mode 15	27	28	Current mode 16
Input 15-	29	30	Input 16-
AG	31	32	AG
NC	33	34	NC

CN1 Inputs 1 to 8

Input 1+	1	2	Input 2+
Current mode 1	3	4	Current mode 2
Input 1-	5	6	Input 2-
AG	7	8	AG
Input 3+	9	10	Input 4+
Current mode 3	11	12	Current mode 4
Input 3-	13	14	Input 4-
AG	15	16	AG
Input 15+	17	18	Input 6+
Current mode 5	19	20	Current mode 6
Input 5-	21	22	Input 6-
AG	23	24	AG
Input 7+	25	26	Input 8+
Current mode 7	27	28	Current mode 8
Input 7-	29	30	Input 8-
AG	31	32	AG
NC	33	34	NC

- Note:**
1. The analog input numbers that can be used are set in the Data Memory (DM).
 2. The input signal ranges for each input are set in the Data Memory (DM). They can be set in units of input numbers.
 3. The AG terminals (A8, B8) are connected to the 0-V analog circuit in the Unit. Connecting shielded input lines can improve noise resistance.
 4. Do not make any connections to the N.C. terminals.

Analog Outputs Units CS1W-DA041/DA081/DA08C

Specifications

Item		CS1W-DA041	CS1W-DA08V	CS1W-DA08C
Applicable PLC model		CS series		
Unit type		CS1 Special I/O Unit		
Isolation *1		Between I/O and PLC signals: Photocoupler (No isolation between individual I/O signals.)		
External terminals		21-point detachable terminal block (M3 screws)		
Power consumption		130 mA max. at 5 VDC, 180 mA max. at 26 VDC	130 mA max. at 5 VDC, 180 mA max. at 26 VDC	130 mA max. at 5 VDC, 250 mA max. at 26 VDC
Dimensions (mm) *2		35 × 130 × 126 (W × H × D)		
Weight		450 g max.		
General specifications		Conforms to general specifications for SYSMAC CS-series Series.		
Mounting position		CS-series CPU Rack or CS-series Expansion Rack (Cannot be mounted to a C200H Expansion I/O Rack or a SYSMAC BUS Slave Rack.)		
Maximum number of Units		Depends on the Power Supply Unit. *3		
Data exchange with CPU Units *4		Special I/O Unit Area CIO 200000 to CIO 295915 (Words CIO 2000 to CIO 2959)		
		Internal Special I/O Unit DM Area (D20000 to D29599)		
Output specifications	Number of analog outputs	4	8	8
	Output signal ranges *5	1 to 5 V/4 to 20 mA 0 to 5 V 0 to 10 V -10 to 10V	1 to 5 V 0 to 5 V 0 to 10 V -10 to 10 V	4 to 20 mA
	Output impedance	0.5 Ω max. (for voltage output)		
	Max. output current (for 1 point)	12 mA (for voltage output)		
	Maximum permissible load resistance	600 Ω (current output) *9	—	600 Ω (current output) *8
	Resolution	4,000 (full scale)		
	Set data	16-bit binary data		
	Accuracy *6	23±2°C: Voltage output: ±0.3% of full scale Current output: ±0.5% of full scale 0°C to 55°C: Voltage output: ±0.5% of full scale Current output: ±0.8% of full scale		
D/A conversion time *7	1.0 ms/point max.			
Output functions	Output hold function	Outputs the specified output status (CLR, HOLD, or MAX) under any of the following circumstances. When the Conversion Enable Bit is OFF. *8 In adjustment mode, when a value other than the output number is output during adjustment. When there is an output setting error or a fatal error occurs at the PLC. When the CPU Unit is on standby. When the Load is OFF.		

*1. Do not apply a voltage higher than 600 V to the terminal block when performing withstand voltage test on this Unit.

*2. Refer to *Dimensions* on page 20 for details on the Unit's dimensions.

*3. Maximum Number of Units

Power Supply Unit	CS1W-DA041/08V	CS1W-DA08C
C200HW-PA204 C200HW-PA204S C200HW-PA204R C200HW-PD024	3 Units max.	2 Units max.
C200HW-PA209R	7 Units max.	5 Units max.

The maximum number of Units that can be mounted to one Rack varies depending on the current consumption of the other Units mounted to the Rack and may be less than the number shown in the above table.

*4. Data Exchange with CPU Units

Special I/O Unit Area CIO 200000 to CIO 295915 (Words CIO 2000 to CIO 2959)	Exchanges 10 words of data per Unit.	CPU Unit to Analog Output Unit	Analog output setting data Conversion Enable Bit
		Analog Output Unit to CPU Unit	Alarm flags
Internal Special I/O Unit DM Area (D20000 to D29599)	Transmits 100 words of data per Unit at power-up or when the Unit is restarted.	CPU Unit to Analog Output Unit	Output signal conversion enable/disable, output signal range setting Output status for output hold

*5. Output signal ranges can be set for each output.

*6. The accuracy is given for full scale. For example, an accuracy of ±0.3% means a maximum error of ±12 (BCD).

*7. D/A conversion time is the time required for converting and outputting the PLC data. It takes at least one cycle for the data stored in the PLC to be read by the Analog Output Unit.

*8. When the operation mode for the CPU Unit is changed from RUN mode or MONITOR mode to PROGRAM mode, or when the power is turned ON, the Output Conversion Enable Bit will turn OFF. The output status specified according to the output hold function will be output.

*9. The load resistance is adjusted to 250 Ω at the factory. Always adjust the offset gain before application when the load resistance is not 250 Ω. The CS1W-DA041 is adjusted for current outputs (load resistance: 250 Ω) at the factory. Adjust the offset gain before application when using voltage outputs.

Output Function Block Diagram

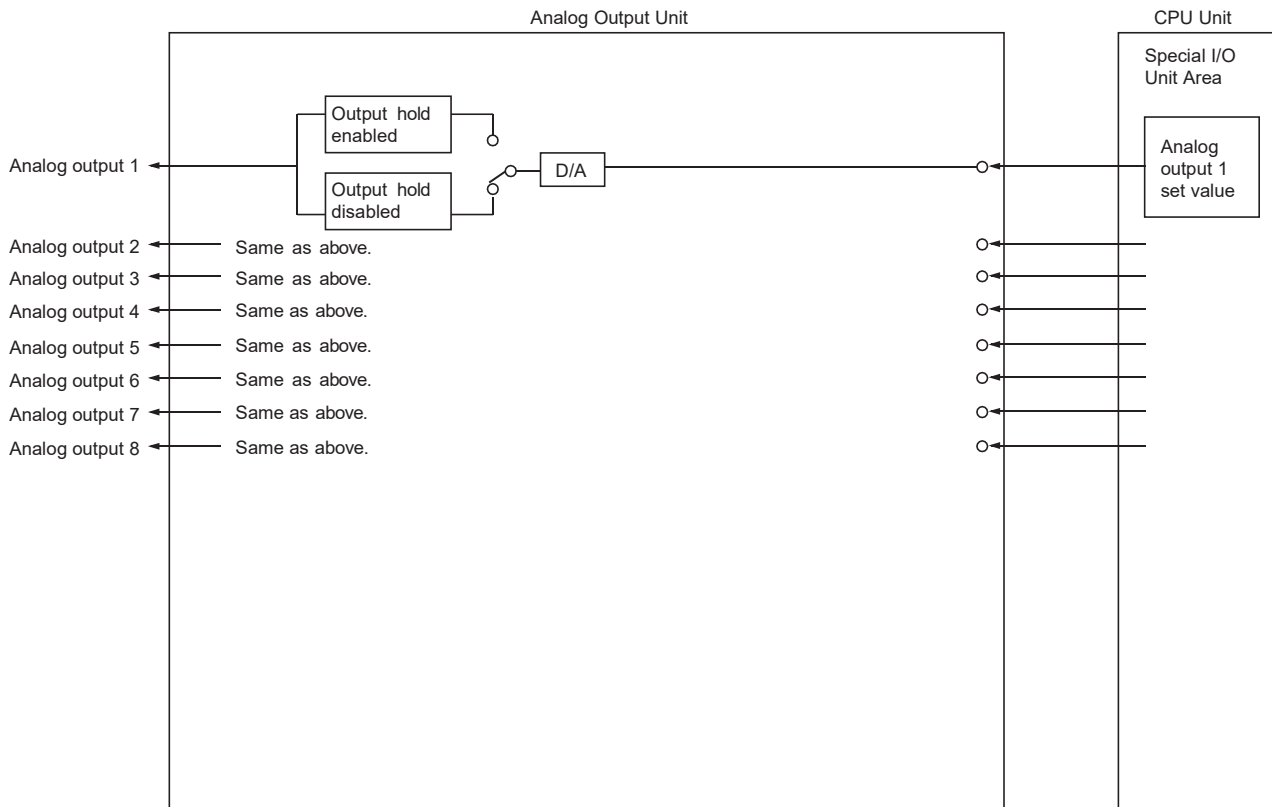

Note: There are only four analog outputs for the CS1W-DA041.

External Interface

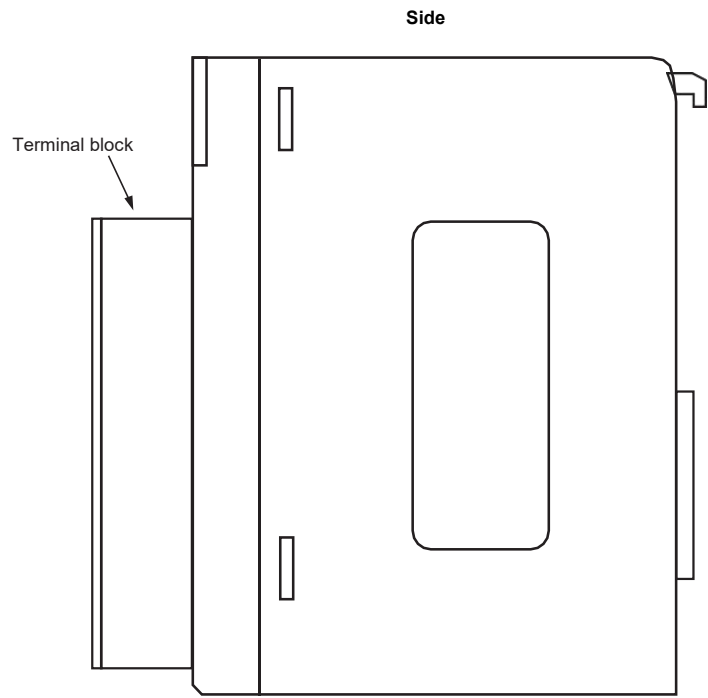
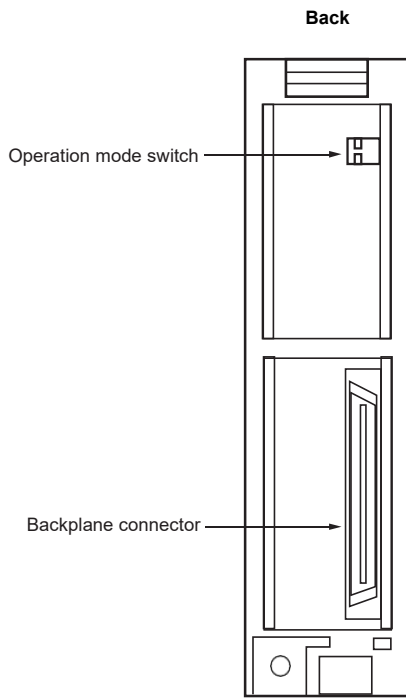
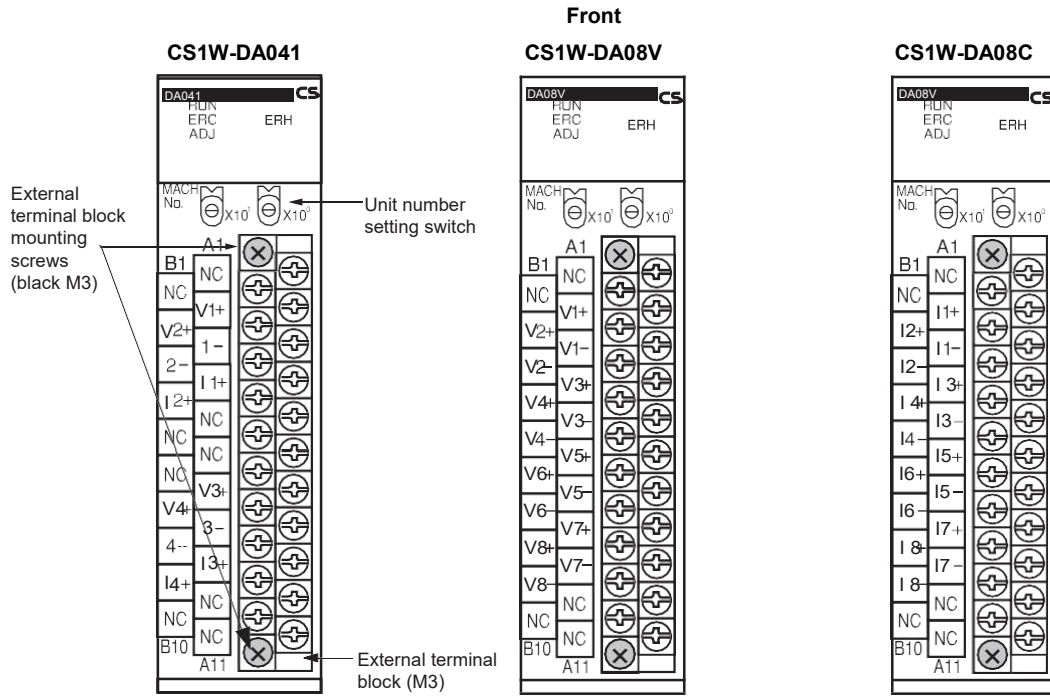

The terminal block is attached by a connector. It can be removed by loosening the two black mounting screws located at the top and bottom of the terminal block.

Check to be sure that the black terminal block mounting screw is securely tightened to a torque of 0.5 N·m.

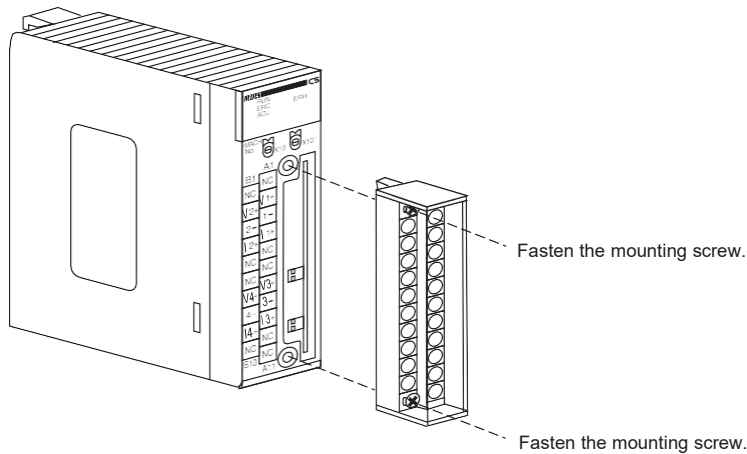

Indicators

The indicators show the operating status of the Unit. The following table shows the meanings of the indicators.

LED	Meaning	Indicator	Operating status
RUN (green)	Operating	Lit	Operating in normal mode.
		Not lit	Unit has stopped exchanging data with the CPU Unit.
ERC (red)	Error detected by Unit	Lit	Alarm has occurred (such as disconnection detection) or initial settings are incorrect.
		Not lit	Operating normally.
ADJ (yellow)	Adjusting	Flashing	Operating in offset/gain adjustment mode.
		Not lit	Other than the above.
ERH (red)	Error in the CPU Unit	Lit	Error has occurred during data exchange with the CPU Unit.
		Not lit	Operating normally.

Internal Circuitry

The following diagrams show the internal circuitry of the analog output section.

Voltage Output Circuitry

Voltage output section for CS1W-DA08V/DA041

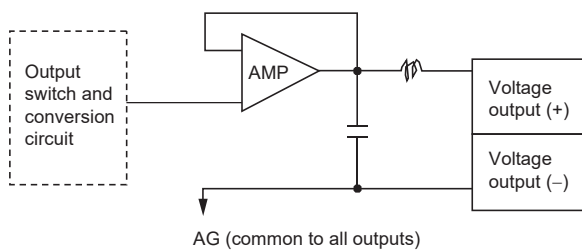

Current Output Circuitry

Current output section for CS1W-DA08C/DA041

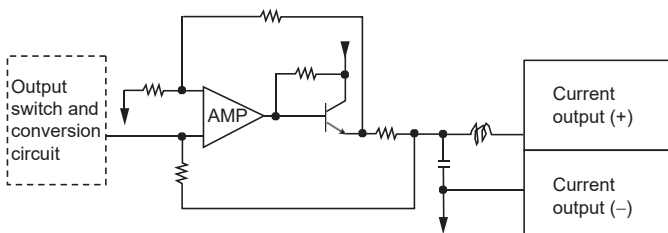

Internal Configuration

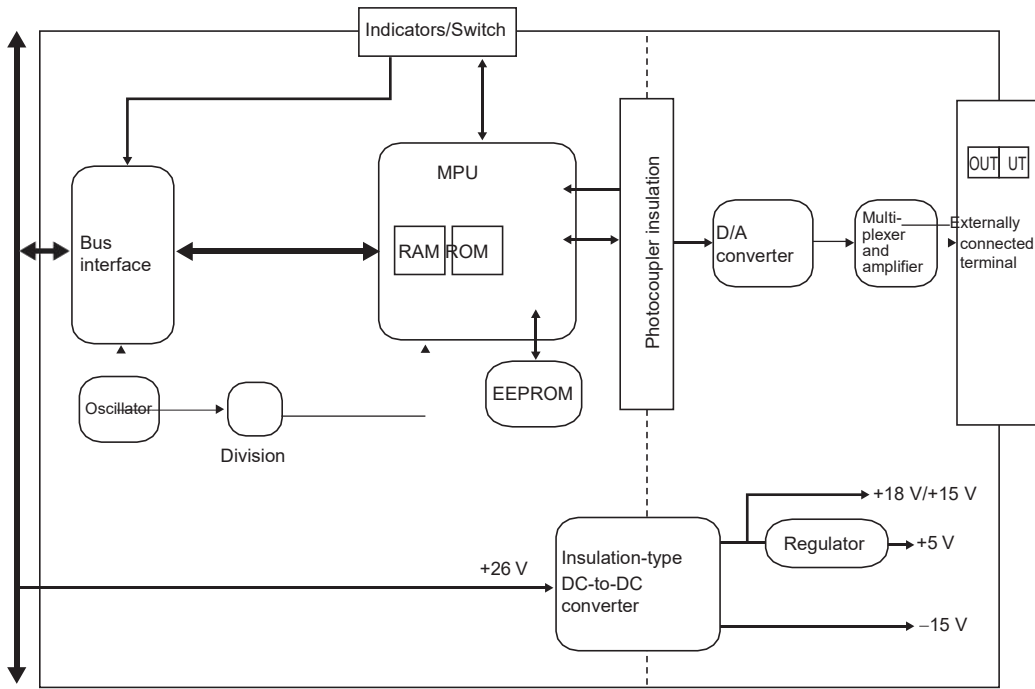

CS-series PLC

Terminal Arrangement

The signal names corresponding to the connecting terminals are as shown in the following diagram.

CS1W-DA08V/08C

N.C.	B1	A1	N.C.
Output 2+	B2	A2	Output 1+
Output 2-	B3	A3	Output 1-
Output 4+	B4	A4	Output 3+
Output 4-	B5	A5	Output 3-
Output 6+	B6	A6	Output 5+
Output 6-	B7	A7	Output 5-
Output 8+	B8	A8	Output 7+
Output 8-	B9	A9	Output 7-
N.C.	B10	A10	N.C.
		A11	N.C.

CS1W-DA041

N.C.	B1	A1	N.C.
Output voltage 2+	B2	A2	Output voltage 1+
Output 2-	B3	A3	Output 1-
Output current 2+	B4	A4	Output current 1+
N.C.	B5	A5	N.C.
N.C.	B6	A6	N.C.
Output voltage 4-	B7	A7	Output voltage 3+
Output 4-	B8	A8	Output 3-
Output current 4+	B9	A9	Output current 3+
N.C.	B10	A10	N.C.
		A11	N.C.

- Note:**
1. The analog output numbers that can be used are set in the Data Memory (DM).
 2. The output signal ranges for individual outputs are set in the Data Memory (DM). They can be set in units of output numbers.
 3. The N.C. terminals are not connected to internal circuitry.

Analog I/O Units CS1W-MAD44

Specifications

Item		CS1W-MAD44					
Applicable PLC model		CS series					
Unit type		CS1 Special I/O Unit					
Isolation		Between I/O and PLC signals: Photocoupler (No isolation between individual I/O signals.)					
External terminals		21-point detachable terminal block (M3 screws)					
Power consumption		200 mA max. at 5 VDC, 200 mA max. at 26 VDC					
Dimensions (mm) *1		35 × 130 × 126 (W × H × D)					
Weight		450 g max.					
General specifications		Conforms to general specifications for SYSMAC CS-series Series.					
Mounting position		CS-series CPU Rack or CS-series Expansion Rack (Cannot be mounted to a C200H Expansion I/O Rack or a SYSMAC BUS Slave Rack.)					
Maximum number of Units	Units per Rack (CPU Rack or Expansion Rack) *2	Power Supply Unit		Maximum number of Units per Rack			
		C200HW-PA204 C200HW-PA204S C200HW-PA204R C200HW-PD024		3 Units max.			
		C200HW-PA209R		6 Units max.			
Units per basic system		When C200HW-PA209R Power Supply Units only are used: 6 Units max. × 8 Racks = 48 Units max.					
Data exchange with CPU Units	Special I/O Unit Area CIO 200000 to CIO 295915 (Words CIO 2000 to CIO 2959)	Exchanges 10 words of data per Unit.	CPU Unit to Analog I/O Unit	Analog output Peak value hold Conversion Enable Bit			
			Analog I/O Unit to CPU Unit	Analog input Input disconnection detection Alarm flags			
	Internal Special I/O Unit DM Area (D20000 to D29599)	Transmits 100 words of data per Unit at power-up or when the Unit is restarted.	CPU Unit to Analog I/O Unit	Input signal conversion enable/disable, input signal range setting Output signal conversion enable/disable, output signal range setting Ratio conversion function setting, constants Output status for output hold Mean value function setting			
Input	Specifications	Input signal *4		Voltage input		Current input	
		Number of analog inputs		4			
		Input signal range *3		1 to 5 V 0 to 5 V 0 to 10 V -10 to 10 V		4 to 20 mA	
		Maximum rated input (for 1 point) *5		±15 V		±30 mA	
		Input impedance		1 MΩ min.		250 Ω (rated value)	
		Resolution		4,000 (full scale)			
		Converted output data		16-bit binary data			
		Accuracy *6		23±2°C	±0.2% of full scale	±0.4% of full scale	
			0°C to 55°C	±0.4% of full scale	±0.6% of full scale		
	A/D conversion time *7		1.0 ms/point max.				
Functions	Mean value processing		Stores the last "n" data conversions in the buffer, and stores the the mean value of the conversion values. Buffer number: n = 2, 4, 8, 16, 32, 64				
	Peak value holding		Stores the maximum conversion value while the Peak Value Hold Bit is ON.				
	Input disconnection detection *9		Detects the disconnection and turns ON the Disconnection Detection Flag.				

Item		CS1W-MAD44		
Output	Specifications	Output signal	Voltage output	
		Number of analog outputs	4	
		Output signal range *3	1 to 5 V 0 to 5 V 0 to 10 V -10 to 10 V	
		Output impedance (for 1 point)	0.5 Ω max.	
		Max. output current	12 mA	
		Resolution	4,000 (full scale)	
		Set data	16-bit binary data	
		Accuracy *6	23±2°C	±0.3% of full scale
			0°C to 55°C	±0.5% of full scale
	D/A conversion time *7		1.0 ms/point max.	
Other	Functions	Output hold function	Outputs the specified output status (CLR, HOLD, or MAX) under any of the following circumstances. When the Conversion Enable Bit is OFF. *8 In adjustment mode, when a value other than the output number is output during adjustment. When there is an output setting error or a fatal error occurs at the PLC. When the CPU Unit is on standby. When the Load is OFF.	
Other	Functions	Ratio conversion function	Stores the results of positive and negative gradient analog inputs calculated for ratio and bias as analog output values. Positive gradient: Analog output = A × Analog input + B (A = 0 to 99.99, B = 8,000 to 7FFF Hex) Negative gradient: Analog output = F - A × Analog input + B (A = 0 to 99.99, B = 8,000 to 7FFF Hex, F = output range max. value)	

- *1. Refer to *Dimensions* on page 20 for details on the Unit's dimensions.
- *2. The maximum number of Analog I/O Units that can be mounted to one Rack will vary depending on the current consumption of the other Units mounted to the Rack.
- *3. Input and output signal ranges can be set for each input and output.
- *4. Voltage input or current input are chosen by using the voltage/current switch at the back of the terminal block.
- *5. The Analog I/O Unit must be operated according to the input specifications provided here. Operating the Unit outside these specifications will cause the Unit to malfunction.
- *6. The accuracy is given for full scale. For example, an accuracy of ±0.2% means a maximum error of ±8 (BCD).
The default setting is adjusted for voltage input. To use current input, perform the offset and gain adjustments as required.
- *7. A/D conversion time is the time it takes for an analog signal to be stored in memory as converted data after it has been input. It takes at least one cycle before the converted data is read by the CPU Unit. D/A conversion time is the time required for converting and outputting the PLC data. It takes at least one cycle for the data stored in the PLC to be read by the Analog I/O Unit.
- *8. When the operation mode for the CPU Unit is changed from RUN mode or MONITOR mode to PROGRAM mode, or when the power is turned ON, the Output Conversion Enable Bit will turn OFF. The output status specified according to the output hold function will be output.
- *9. Input disconnection detection is valid only when the 1 to 5-V or 4 to 20-mA range is set. If there is no input signal for when the 1 to 5-V or 4 to 20-mA range is set, the Disconnection Detection Flag will turn ON.

I/O Function Block Diagram

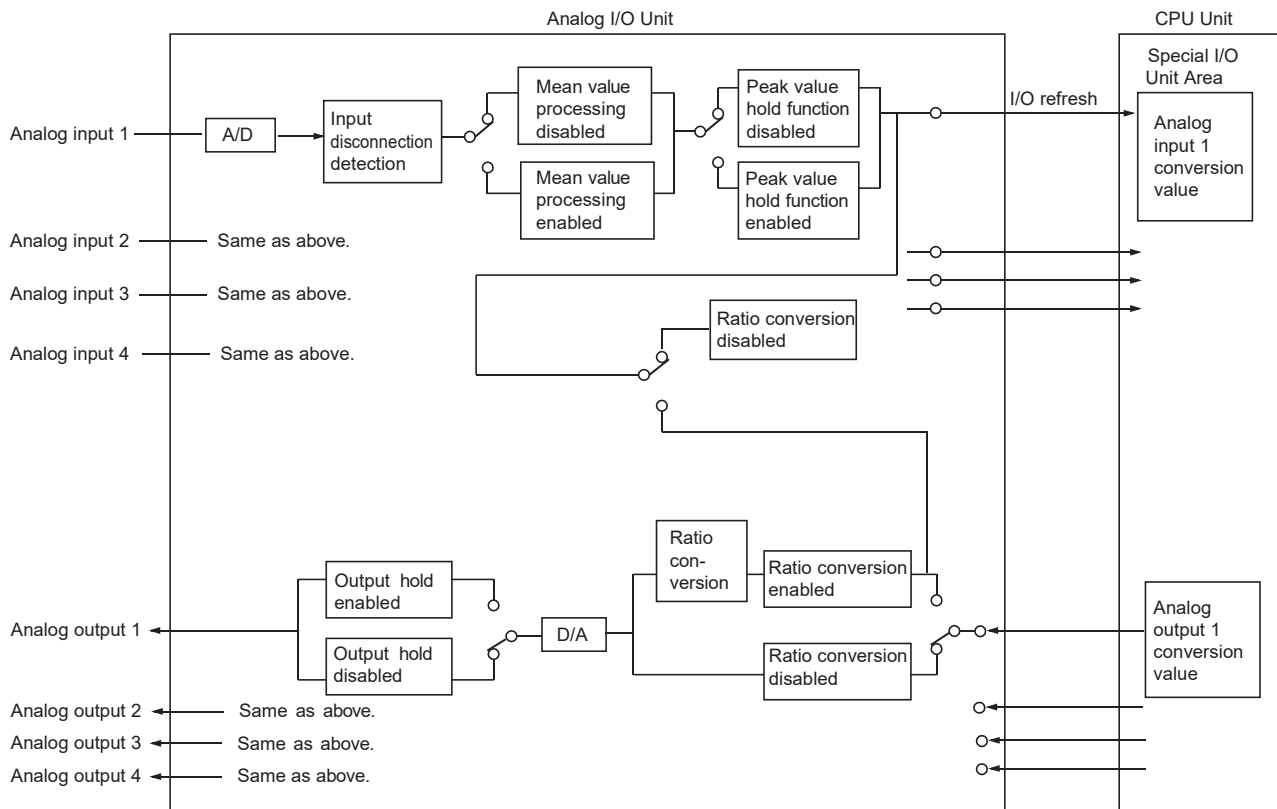

External Interface

CS1W-MAD44

Front

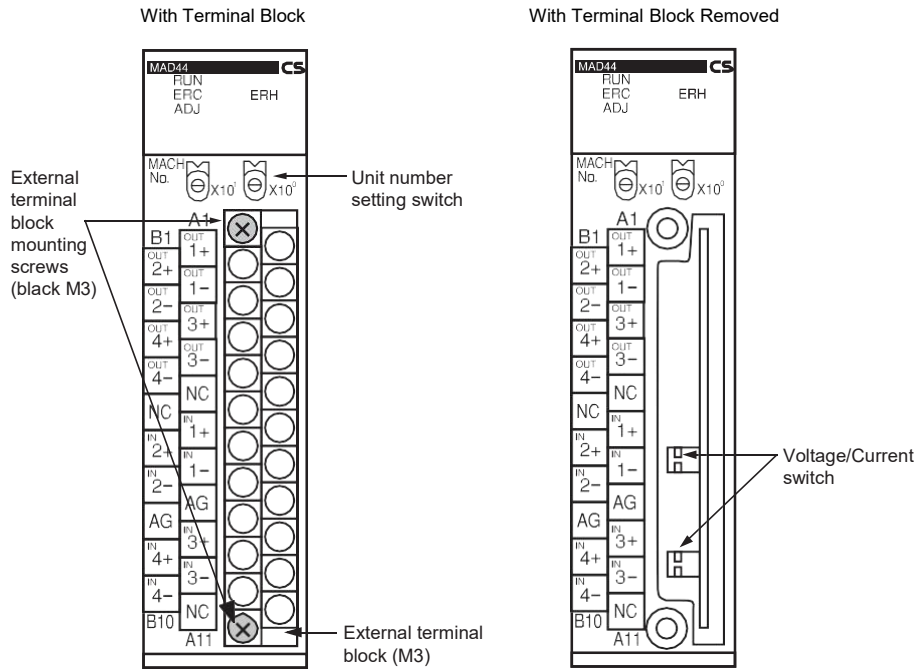

Back

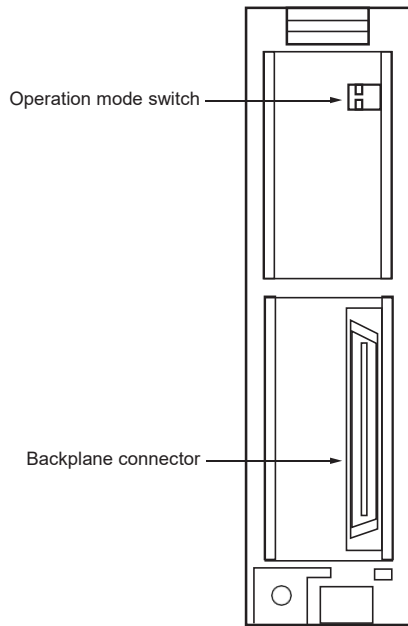

Side

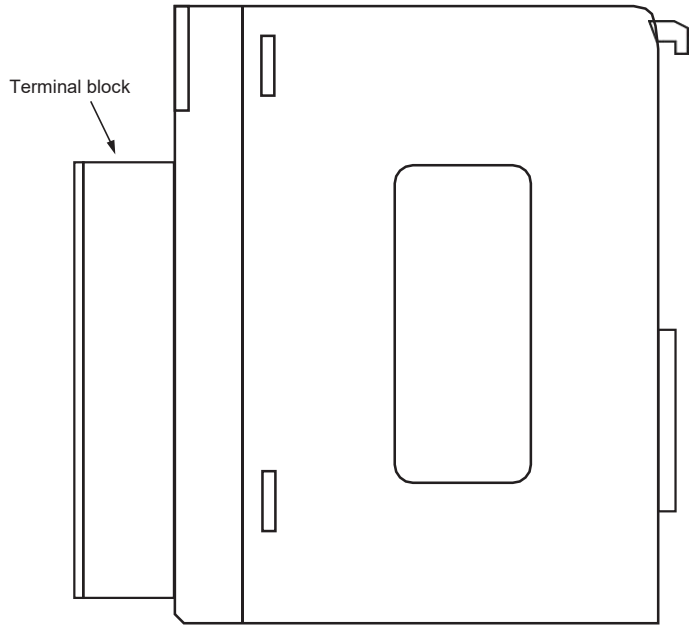

The terminal block is attached by a connector. It can be removed by loosening the two black mounting screws located at the top and bottom of the terminal block.

Check to be sure that the black terminal block mounting screw is securely tightened to a torque of 0.5 N·m.

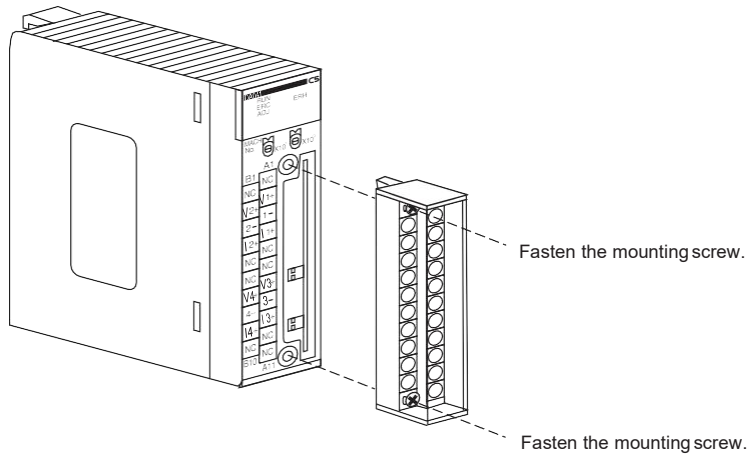

Indicators

The indicators show the operating status of the Unit. The following table shows the meanings of the indicators.

LED	Meaning	Indicator	Operating status
RUN (green)	Operating	Lit	Operating in normal mode.
		Not lit	Unit has stopped exchanging data with the CPU Unit.
ERC (red)	Error detected by Unit	Lit	Alarm has occurred (such as disconnection detection) or initial settings are incorrect.
		Not lit	Operating normally.
ADJ (yellow)	Adjusting	Flashing	Operating in offset/gain adjustment mode.
		Not lit	Other than the above.
ERH (red)	Error in the CPU Unit	Lit	Error has occurred during data exchange with the CPU Unit.
		Not lit	Operating normally.

Internal Circuitry

The following diagrams show the internal circuitry of the analog I/O section.

Input Circuitry

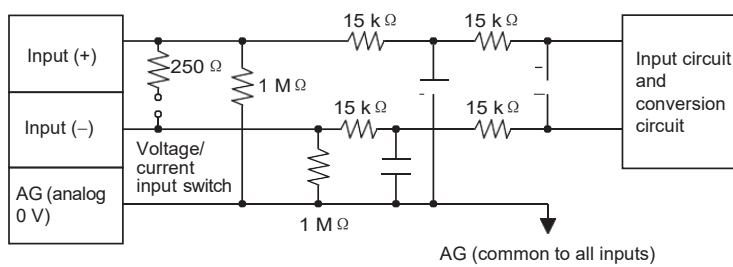

Output Circuitry

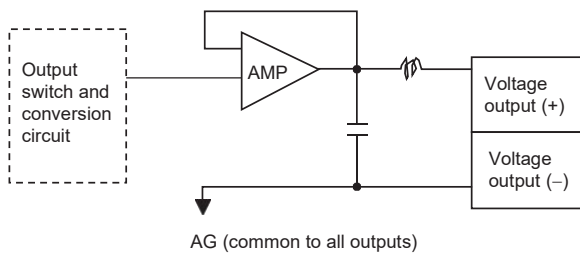

Internal Configuration

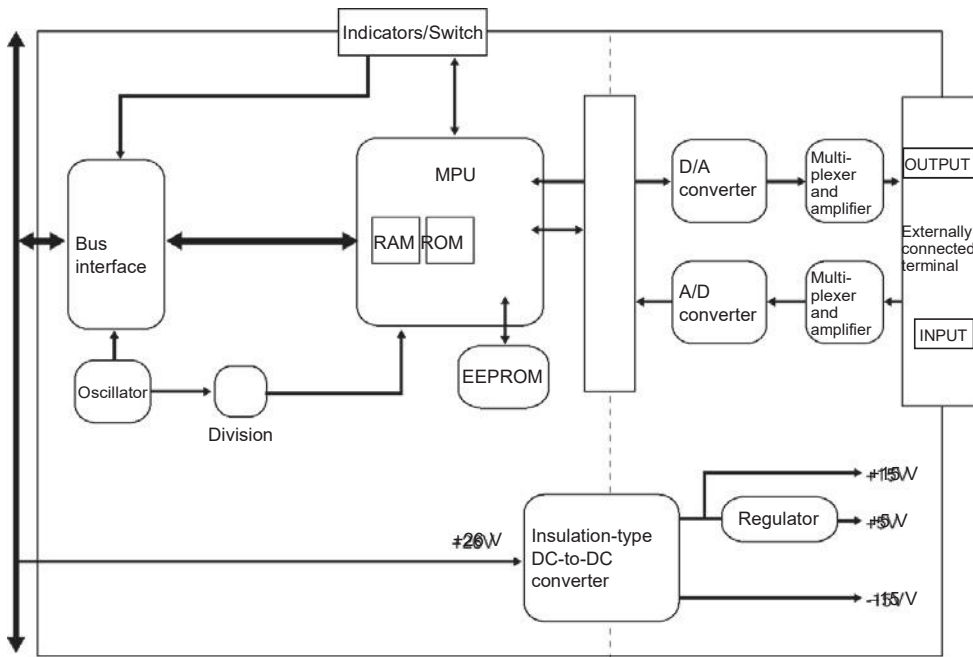

CS-series PLC

Terminal Arrangement

The signal names corresponding to the connecting terminals are as shown in the following diagram.

Output 2+	B1	A1	Output 1+
Output 2-	B2	A2	Output 1-
Output 4+	B3	A3	Output 3+
Output 4-	B4	A4	Output 3-
N.C.	B5	A5	N.C.
Input 2+	B6	A6	Input 1+
Input 2-	B7	A7	Input 1-
AG	B8	A8	AG
Input 4+	B9	A9	Input 3+
Input 4-	B10	A10	Input 3-
		A11	N.C.

- Note:**
1. The analog I/O numbers that can be used are set in the Data Memory (DM).
 2. The I/O signal ranges for individual inputs and outputs are set in the Data Memory (DM). They can be set in units of I/O numbers.
 3. The AG terminal (A8, B8) is connected to the 0-V analog circuit in the Unit. Connecting shielded input lines can improve noise resistance.
 4. The N.C. terminals (A5, A11, B5) are not connected to internal circuitry.

Dimensions

CS-series Units: CS1W-AD041-V1/081-V1, CS1W-DA08V/08C/041, CS1W-MAD44

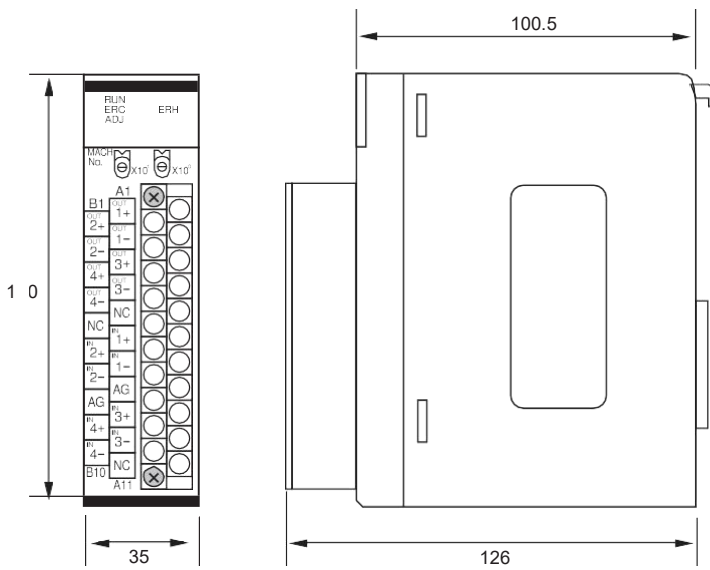

CS1W-AD161

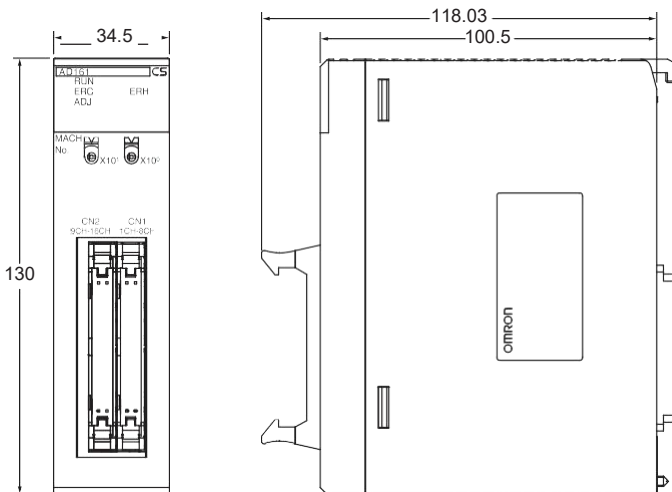

CS-series Unit Terminal Block Dimensions

Terminal size: M3

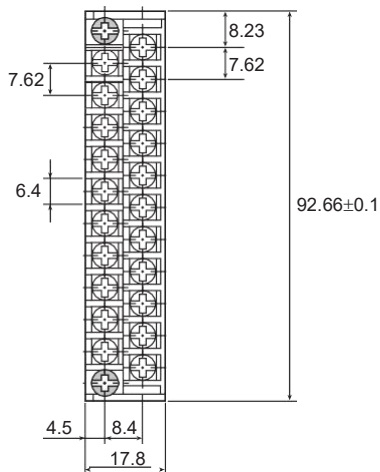

About this Manual

Name	Cat. No.	Contents
SYSMAC CS/CJ-series Analog I/O Units Operation Manual CS1W-AD041-V1/AD081-V1/AD161, CS1W-DA041/DA08V/DA08C, CS1W-MAD44, CJ1W-AD041-V1/AD081-V1, CJ1W-DA021/DA041/DA08V/DA08C, CJ1W-MAD42	W345	Describes the application methods of the CS/CJ-series Analog Input, Analog Output, and Analog I/O Units.
SYSMAC CS-series Programmable Controllers Operation Manual CS1G/H-CPU@@-EV1, CS1G/H-CPU@@H	W339	Describes the installation and operation of the CS-series PLCs.
SYSMAC CS Series CS1D Duplex System Operation Manual CS1D-CPU@@HA CPU Units, CS1D-CPU@@SA CPU Units, CS1D-CPU@@H CPU Units, CS1D-CPU@@S CPU Units, CS1D-DPL01 Duplex Unit, CS1D-PA/PD@@@ Power Supply Unit	W405	Provides an outline of and describes the design, installation, maintenance, and other basic operations for a Duplex System based on CS1D CPU Units.
CJ-series PLCs Operation Manual CJ1H-CPU@@H-R, CJ1G/H-CPU@@H, CJ1G-CPU@@P, CJ1G-CPU@@, CJ1H-CPU@@	W393	Provides the following information on CJ-series PLCs: <ul style="list-style-type: none"> • Overview and features • System configuration design • Installation and wiring • I/O memory allocations • Troubleshooting
CS/CJ/NSJ-series PLCs Programming Manual CS1G/H-CPU@@H, CS1G/H-CPU@@-V1, CS1D-CPU@@HA, CS1D-CPU@@SA, CS1D-CPU@@H, CS1D-CPU@@S, CJ1H-CPU@@H-R, CJ1G/H-CPU@@H, CJ1G-CPU@@P, CJ1M-CPU@@, CJ1G-CPU@@, NSJ@@@@(B)-G5D, NSJ@@@@(B)-M3D	W394	Provides the following information on CS/CJ/NSJ-series PLCs: <ul style="list-style-type: none"> • Programming • Task functions • File memory • Various operations
CS/CJ/NSJ-series PLCs Instructions Reference Manual CS1G/H-CPU@@H, CS1G/H-CPU@@-V1, CS1D-CPU@@HA, CS1D-CPU@@SA, CS1D-CPU@@H, CS1D-CPU@@S, CJ1H-CPU@@H-R, CJ1G/H-CPU@@H, CJ1G-CPU@@P, CJ1M-CPU@@, CJ1G-CPU@@, NSJ@@@@(B)-G5D, NSJ@@@@(B)-M3D	W474	Describes all the ladder programming instructions in detail.
CX-Programmer Operation Manual (Version 8.0) WS02-CXPC@-V8	W446	Describes how to use the CX-Programmer.
SYSMAC CS/CJ-series Programming Consoles Operation Manual CQM1H-PRO01, CQM1-PRO01, C200H-PRO27 + CS1W-KS001	W341	Describes how to use the Programming Console.

Terms and Conditions Agreement

Read and understand this catalog.

Please read and understand this catalog before purchasing the products. Please consult your OMRON representative if you have any questions or comments.

Warranties.

(a) **Exclusive Warranty.** Omron's exclusive warranty is that the Products will be free from defects in materials and workmanship for a period of twelve months from the date of sale by Omron (or such other period expressed in writing by Omron). Omron disclaims all other warranties, express or implied.

(b) **Limitations.** OMRON MAKES NO WARRANTY OR REPRESENTATION, EXPRESS OR IMPLIED, ABOUT NON-INFRINGEMENT, MERCHANTABILITY OR FITNESS FOR A PARTICULAR PURPOSE OF THE PRODUCTS. BUYER ACKNOWLEDGES THAT IT ALONE HAS DETERMINED THAT THE PRODUCTS WILL SUITABLY MEET THE REQUIREMENTS OF THEIR INTENDED USE.

Omron further disclaims all warranties and responsibility of any type for claims or expenses based on infringement by the Products or otherwise of any intellectual property right. (c) **Buyer Remedy.** Omron's sole obligation hereunder shall be, at Omron's election, to (i) replace (in the form originally shipped with Buyer responsible for labor charges for removal or replacement thereof) the non-complying Product, (ii) repair the non-complying Product, or (iii) repay or credit Buyer an amount equal to the purchase price of the non-complying Product; provided that in no event shall Omron be responsible for warranty, repair, indemnity or any other claims or expenses regarding the Products unless Omron's analysis confirms that the Products were properly handled, stored, installed and maintained and not subject to contamination, abuse, misuse or inappropriate modification. Return of any Products by Buyer must be approved in writing by Omron before shipment. Omron Companies shall not be liable for the suitability or unsuitability or the results from the use of Products in combination with any electrical or electronic components, circuits, system assemblies or any other materials or substances or environments. Any advice, recommendations or information given orally or in writing, are not to be construed as an amendment or addition to the above warranty.

See <http://www.omron.com/global/> or contact your Omron representative for published information.

Limitation on Liability; Etc.

OMRON COMPANIES SHALL NOT BE LIABLE FOR SPECIAL, INDIRECT, INCIDENTAL, OR CONSEQUENTIAL DAMAGES, LOSS OF PROFITS OR PRODUCTION OR COMMERCIAL LOSS IN ANY WAY CONNECTED WITH THE PRODUCTS, WHETHER SUCH CLAIM IS BASED IN CONTRACT, WARRANTY, NEGLIGENCE OR STRICT LIABILITY.

Further, in no event shall liability of Omron Companies exceed the individual price of the Product on which liability is asserted.

Suitability of Use.

Omron Companies shall not be responsible for conformity with any standards, codes or regulations which apply to the combination of the Product in the Buyer's application or use of the Product. At Buyer's request, Omron will provide applicable third party certification documents identifying ratings and limitations of use which apply to the Product. This information by itself is not sufficient for a complete determination of the suitability of the Product in combination with the end product, machine, system, or other application or use. Buyer shall be solely responsible for determining appropriateness of the particular Product with respect to Buyer's application, product or system. Buyer shall take application responsibility in all cases.

NEVER USE THE PRODUCT FOR AN APPLICATION INVOLVING SERIOUS RISK TO LIFE OR PROPERTY OR IN LARGE QUANTITIES WITHOUT ENSURING THAT THE SYSTEM AS A WHOLE HAS BEEN DESIGNED TO ADDRESS THE RISKS, AND THAT THE OMRON PRODUCT(S) IS PROPERLY RATED AND INSTALLED FOR THE INTENDED USE WITHIN THE OVERALL EQUIPMENT OR SYSTEM.

Programmable Products.

Omron Companies shall not be responsible for the user's programming of a programmable Product, or any consequence thereof.

Performance Data.

Data presented in Omron Company websites, catalogs and other materials is provided as a guide for the user in determining suitability and does not constitute a warranty. It may represent the result of Omron's test conditions, and the user must correlate it to actual application requirements. Actual performance is subject to the Omron's Warranty and Limitations of Liability.

Change in Specifications.

Product specifications and accessories may be changed at any time based on improvements and other reasons. It is our practice to change part numbers when published ratings or features are changed, or when significant construction changes are made. However, some specifications of the Product may be changed without any notice. When in doubt, special part numbers may be assigned to fix or establish key specifications for your application. Please consult with your Omron's representative at any time to confirm actual specifications of purchased Product.

Errors and Omissions.

Information presented by Omron Companies has been checked and is believed to be accurate; however, no responsibility is assumed for clerical, typographical or proofreading errors or omissions.

2018.11

In the interest of product improvement, specifications are subject to change without notice.

OMRON Corporation
Industrial Automation Company

<http://www.ia.omron.com/>

(c) Copyright OMRON Corporation 2018 All Right Reserved.