

Easy-to-use, Space-saving 16-point Output terminal



For the most recent information on models that have been certified for safety standards, refer to your OMRON website.

- Slim terminal block is just 135 × 40 mm (W × D).
- Independent contacts and short bars allow easy common connections.
- An Expansion Terminal Block can be mounted for power line connections.
- M3.5 fork-type crimp terminals (with a maximum terminal width of 6.2 mm) can be used.
- Lever mechanism allows Relays to be installed and removed easily without tools.
- Relay models and power MOSFET Relay models are available.
- Equipped with operation indicators.
- Can be combined with a DRT2-OD32ML I/O Terminal for DeviceNet connectivity or an SRT2-VOD16ML Connector Terminal for CompoBus/S connectivity.
- Built-in diode absorbs coil surge.
- Mount either to DIN rail or via screws.

Ordering Information

Relay Terminals

Classification	Points	Internal I/O common	Rated voltage	Model
Relay outputs	16 points (SPST-NO × 16)	NPN (+common)	24 V DC	G70D-VSOC16
Power MOSFET relay outputs				G70D-VFOM16

Note: These are all non-standard model and require a special order. Contact your OMRON representative for details on availability.

Accessories (Order Separately)

Cables for I/O Relay Terminals XW2Z-R

- Cable with Loose Wire and Crimp Terminals: XW2Z-RY@C
- Cable with Loose Wires: XW2Z-RA@C
- Cable with connectors
 - Fujitsu connectors (1:1): XW2Z-R@C
 - (1:2): XW2Z-RI@C-@
 - XW2Z-RO@C-@
 - (1:3): XW2Z-R@C-@-@
 - MIL connectors (1:1): XW2Z-RI@C
 - XW2Z-RO@C
 - (1:2): XW2Z-RI@-@-D@
 - XW2Z-RM@-@-D@
 - XW2Z-RO@-@-D1

Refer to the **XW2Z-R** Datasheet (Cat. No. G126) for details.

Expansion Terminal Block

Applicable Output Relay Terminals	Appearance	Model
G70D-VSOC16		G70D-ET *
G70D-VFOM16		

* This is a non-standard model and requires a special order. Contact your OMRON representative for details on availability.

Short Bar

Applicable Output Relay Terminals	Appearance	Model
G70D-VSOC16		G6D-4-SB
G70D-VFOM16		

Replacement Relays

Applicable Output Relay Terminals	Rated voltage	Model
G70D-VSOC16	24 V DC	G6D-1A-ASI-AP DC24 *
G70D-VFOM16		G3DZ-2R6PL DC24 *

* This is a non-standard model and requires a special order. Contact your OMRON representative for details on availability.

Accessories for DIN Track Mounting

Refer to your OMRON website for details on the PFP-@.

Specifications

Ratings

Relay Specifications

The following specifications apply to G6D Relays mounted in a G70D Relay Terminal and not the G6D Relay itself.

Coil Ratings (per G6D Relay)

Rated voltage	24 V DC
Rated current	10.5 mA
Coil resistance	2,880 Ω
Must-operate voltage	70% max. of rated voltage
Must release voltage	10% min. of rated voltage
Max. voltage	130% of rated voltage
Power consumption	Approx. 200 mW

- Note:**
1. The must-operate voltage is 75% or less of the rated voltage if the relay is mounted upside down.
 2. Rated current and coil resistance were measured at a coil temperature of 23° C with a tolerance of $\pm 10\%$.
 3. Operating characteristics were measured at a coil temperature of 23° C.
 4. The maximum allowable voltage is the maximum value of the allowable voltage range for the relay coil operating power supply. There is no continuous allowance.
 5. The rated current includes the terminal's LED current.

Contact Ratings (per G6D Relay)

Load	Resistive load ($\cos\phi = 1$)	
Rated load	3 A at 250 V AC, 3 A at 30 V DC	
Rated carry current	5 A *1	
Max. switching voltage	250 V AC, 30 V DC	
Max. switching current	5 A	
Max. switching capacity (reference value)	1,250 VA, 150 W	
Min. permissible load (reference value) *1	5 V DC, 1 mA	
Endurance	Electrical	100,000 operations min. (under and at the rated load at 1,800 operations/h)
	Mechanical	20,000,000 operations min. (at 18,000 operations/h)

*1. Up to 5 A can be carried when 8 or fewer outputs are ON.

*2. This value is for a switching frequency of 120 times per minute.

Power MOSFET Relay Specifications

The following values apply to G3DZ Relays mounted in a G70D Output Block and not the G3DZ Relay itself.

Input (per G3DZ Power MOSFET Relay)

Rated voltage	24 V DC	
Operating voltage	19.2 to 28.8 V DC	
Voltage level	Must-operate	19.2 V DC max.
	Must release	1 V DC min.
Input impedance	4 k Ω $\pm 20\%$	
Rated current	8.2 mA $\pm 20\%$	

Note: The rated current includes the current consumption of the operation indicator.

Output (per G3DZ Power MOSFET Relay)

Load voltage	3 to 264 V AC, 3 to 125 V DC	
Load current	100 μ A to 0.3 A	
Inrush current	6 A (10 ms)	

Characteristics

Item	G70D-VSOC16	G70D-VFOM16
	Relay outputs	Power MOSFET Relay outputs
Contact configuration	16 points (SPST-NO × 16)	
Contact structure	Single	---
Contact resistance	100 mΩ max. *1	---
Isolation method	---	Photocoupler
Must-operate time	10 ms max. *2	10 ms max.
Release time	10 ms max. *2	15 ms max.
Output ON-resistance	---	2.4 Ω max.
Open-circuit leakage current	---	10 μA max. (at 125 V DC)
Max. switching frequency	Mechanical: 18,000 operations/h Rated load: 1,800 operations/h	---
Insulation resistance	100 MΩ min. (at 500 V DC)	
Dielectric strength	2,000 V AC for 1 min between coil and contact	2,000 V AC for 1 min between input and output terminals
Noise immunity	Power input (normal mode): 600 V for 10 min with a pulse width of 100 ns to 1 μs Power input (common mode): 1.5 kV for 10 min with a pulse width of 100 ns to 1 μs Input cable (coiling): 1.5 kV for 10 min with a pulse width of 100 ns to 1 μs Unit body (coiling): 600 V for 10 min with a pulse width of 100 ns to 1 μs	
Vibration resistance	Destruction: 10 to 55 to 10 Hz, 0.5-mm amplitude (1.0-mm double) Malfunction: 10 to 55 to 10 Hz, 0.375-mm amplitude (0.75-mm double)	
Shock resistance	Destruction: 300 m/s ² , Malfunction: 100 m/s ²	
Operating voltage range	24 V DC ^{+10%} / _{-15%}	
Current consumption	Approx. 170 mA at 24 V DC *3	Approx. 125 mA at 24 V DC *4
Cable length	Between block and controller: 5 m max. (reference value for AWG28) Between block and external device: Dependent on load	
LED color	Operation indicator: orange	
Coil surge absorber	Diode (600 V, 1 A)	
Ambient temperature	Operating: -25 to 55°C (with no icing or condensation)	
Ambient humidity	Operating: 45% to 85%	
Mounting strength	No damage when 49 N pull load was applied for 1 s in all directions (except for 9.8 N in direction of rail)	
Terminal strength	Tightening torque: 0.78 to 118 N·m Pull strength: 49 N for 1 min	
Weight *5	Approx. 280 g	

Note: These values are initial values.

*1. Measurement: 1 A at 5 V DC

*2. Ambient temperature: 23°C

*3. Current consumption is when all points are ON and includes G6D Relay coil current but does not include any external load current.

*4. Current consumption is when all points are ON and includes G3DZ input current but does not include any external load current.

*5. The Unit weighs approximately 315 g with the Expansion Terminal Block mounted.

Engineering Data (Reference Value)

G70D-VSOC16 Maximum Switching Capacity

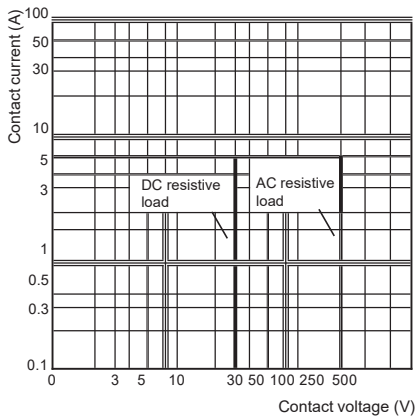

Endurance Curve

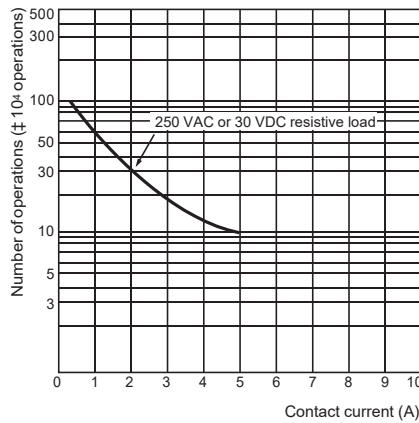

G70D-VFOM16 Load Current vs. Ambient Temperature

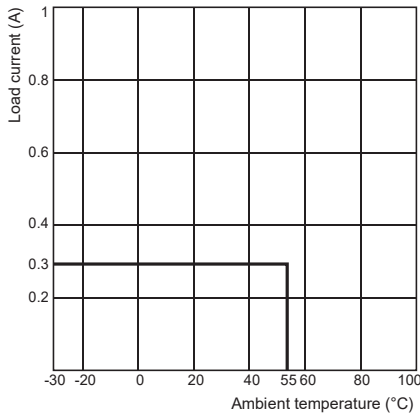

Surge Withstand Current

Non-repetitive (If repetitive, keep the inrush current below the dotted line.)

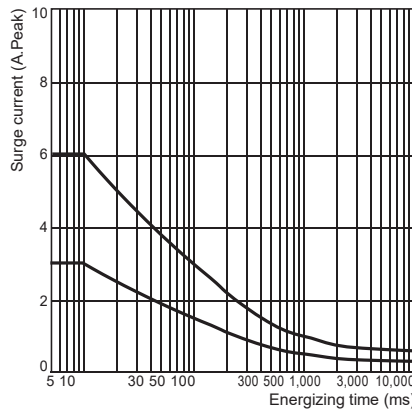

Note: The data given here is a graphic representation of actual values that were sampled on a manufacturing line. It is provided here for reference only. The Relays are mass-produced and therefore must be used to allow for a certain amount of variation in characteristics.

Internal Circuits

G70D-VSOC16/G70D-VFOM16 (NPN output/+ common)

Note: A controller with an NPN transistor, common output can be connected to the G70D-VSOC16/G70D-VFOM16.

Connector Pin Configuration (Top View)

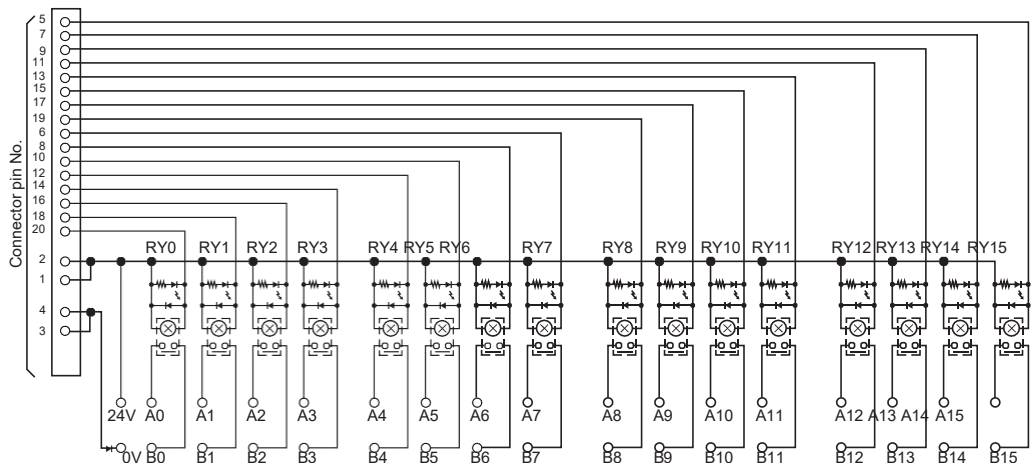
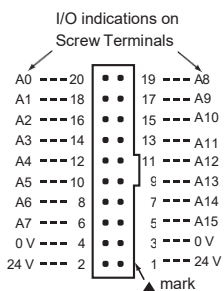

When an expansion terminal block is added

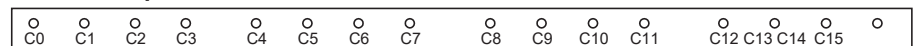

- Note:**
1. The above diagram is for the G70D-VSOC16-1 (model for mounting G6D Relays). The G70D-VFOM16 has a G3DZ Power MOF FET relay for the relay unit.
 2. C0 to C15 are electrically independent.
 3. When the terminal block and relay block are connected, each terminal is electrically connected to the electrical check terminal with the same number on the relay block.

Dimensions

Relay Terminals

G70D-VSOC16
G70D-VFOM16

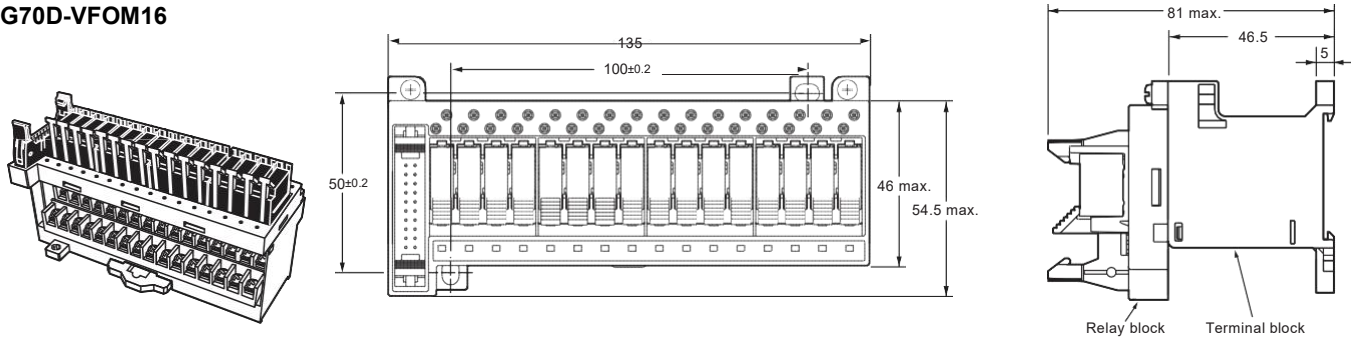

Terminal block (without expansion terminals)

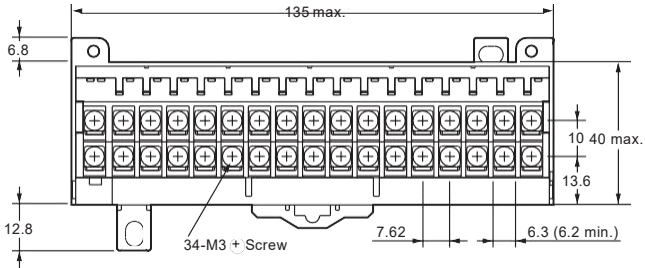

Mounting Hole Dimensions

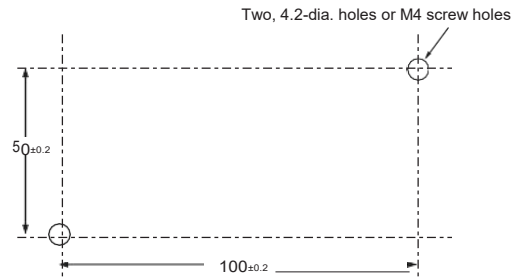

Terminal block (expansion terminal block connected)

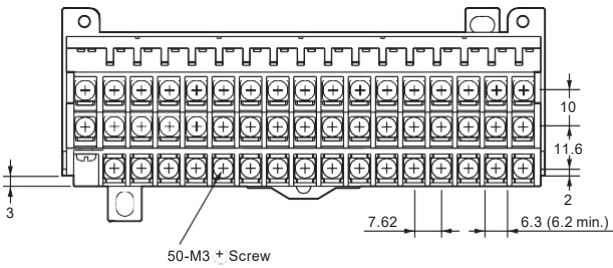

Examples of compatible Y fork type crimp terminals for M3.5

Manufacturer	Model	Terminal width
J.S.T. Mfg. Co., Ltd.	1.25-C3.5A	5.6
Nichifu Co., Ltd.	1.25Y-3.5	5.8
	2Y-3.5S	
Nippon Tanshi Co.,Ltd.	VD1.25-3.5SS	5.7
	VD2-3.5SS	

Accessories (Order Separately)

Expansion Terminal Block G70D-ET

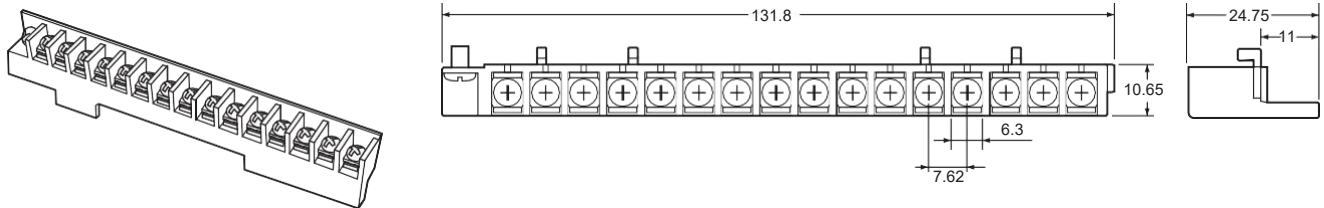

Short Bar G6D-4-SB

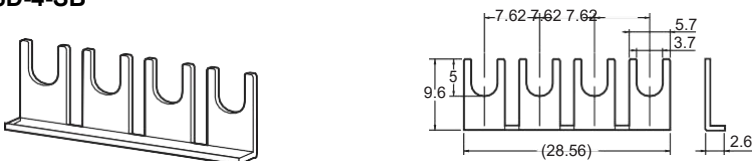

Terminal Arrangement/Terminal Connection Example

G70D-VSOC16
G70D-VFOM16

Without expansion terminal block

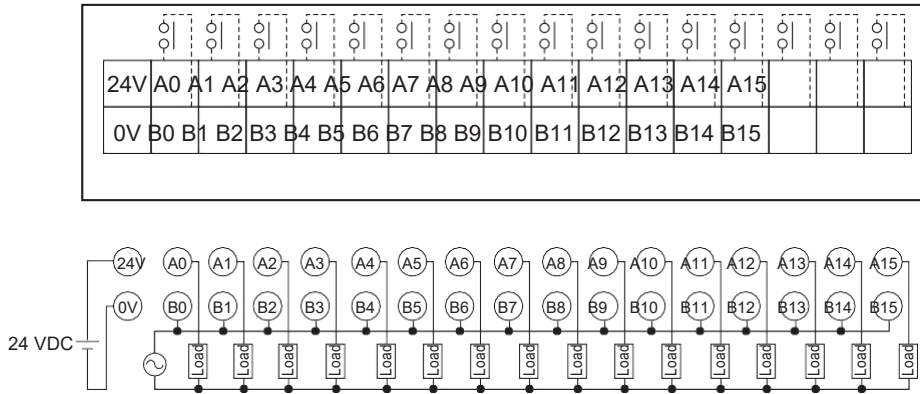

Expansion terminal block added

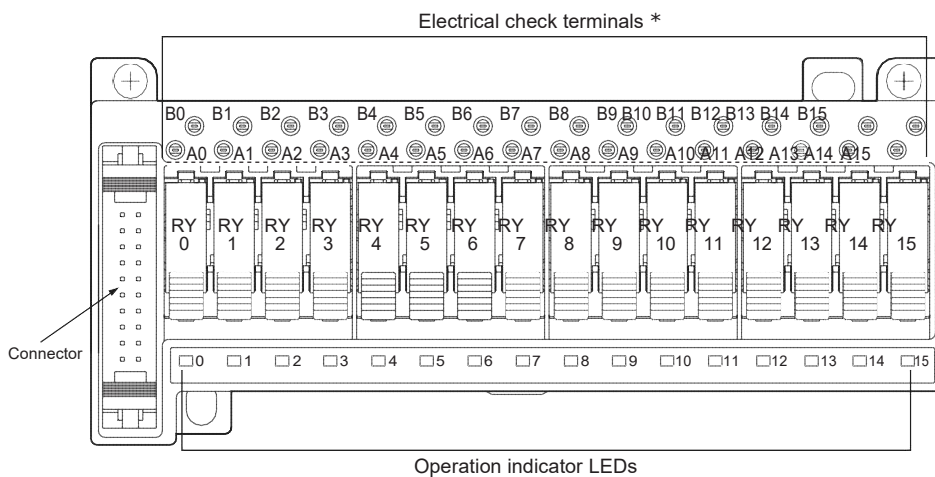
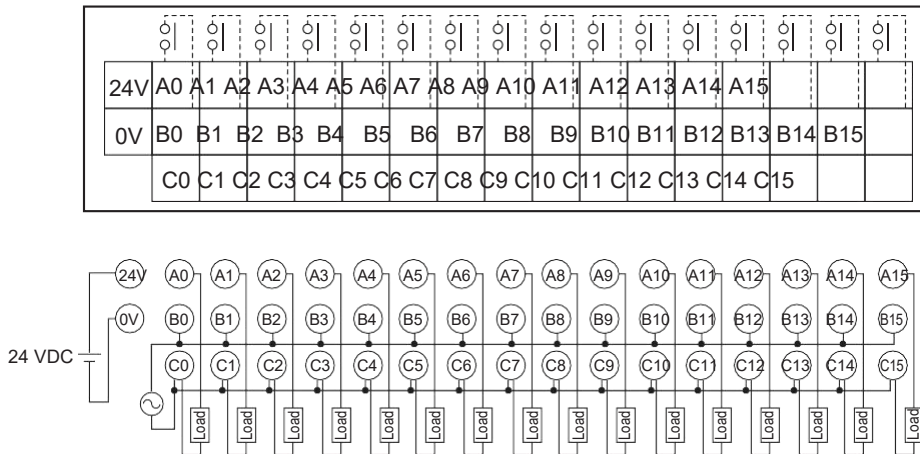

* When the terminal block and relay block are connected, each terminal is electrically connected to the electrical check terminal with the same number on the relay block.

Safety Precautions

Be sure to read *the Safety Precautions for All I/O Relay Terminals* in the website at: <http://www.ia.omron.com/>.

Warning Indications

Precautions for Correct Use	Supplementary comments on what to do or avoid doing, to prevent failure to operate, malfunction, or undesirable effects on product performance.
------------------------------------	---

Precautions for Correct Use

Main unit structure

- The G70D-VSOC16/VFOM16 is structured to separate the wired terminal block and relay block in order to achieve both ease of use and space savings. The relay block has LEDs for operation confirmation, electrical check terminals, and relays. An expansion terminal block can be added as needed for power supply wiring.

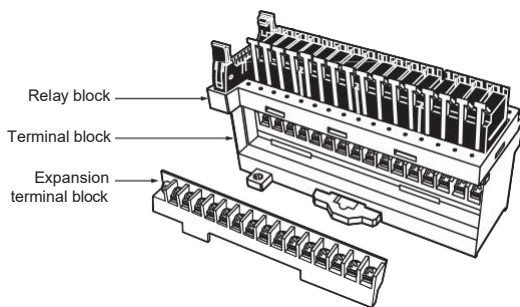

How to remove/attach the terminal block and relay block

(1) Removal

- Verify that the load power and terminal power are off.
- Alternately and evenly turn the relay block mounting screws counterclockwise. The relay block is pressed up.
- When slightly pressed up, separate the tab on part A of the relay block from the side wall.
- Turn the screws further counterclockwise, remove the screws, and then remove the relay block.

(2) Attachment

- Verify that the load power and terminal power are off.
- Verify that there are no metal debris or contaminants on part B of the terminal block.
- Insert the relay block straight along the groove in the terminal block.
- Push in both ends of the relay block, and insert the tab on part A in the side wall.
- Tighten the relay block screws alternately and evenly clockwise to fasten the relay block.

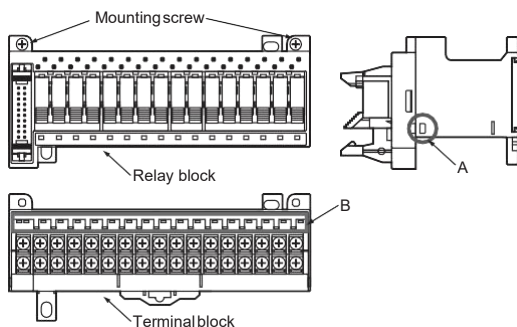

Terminal block name plate

- The terminal block name plate is stored under the relay block as shown in Fig. 1.
- If you need to make a new inscription on the name plate, remove from under the relay block, inscribe, and store in the original location.
- To check the content of the inscription after attaching to the control panel or otherwise, pull out from under the relay block and check.

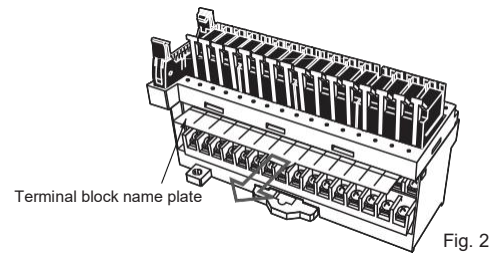
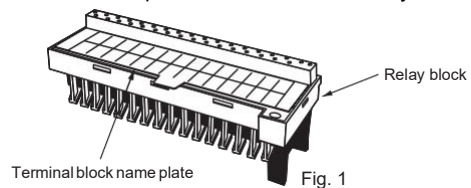

Mounting the expansion terminal block

- Insert the catches on the expansion terminal block into the mounting holes in the terminal block, and slide so that the block will not come off.
- Tighten the mounting screw to fasten.

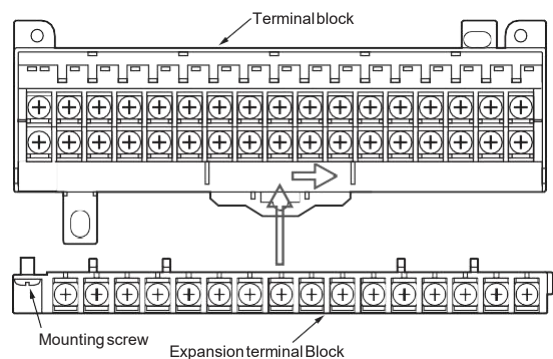

Electrical check method

- When in use, the terminal block of the G70D-VSOC16/VFOM16 is under the relay block, and an electrical check cannot be performed by touching the tester to the screw heads as is done with a regular terminal block. For this reason, electrical check terminals are provided on the relay block. These check terminals are connected to the terminals with the corresponding numbers.
- To perform an electrical check, the tester probe can be touched to the electrical check terminals to check operation.
- When power is present, do not directly touch with a small metal fragment or other object. Risk of electrical shock.

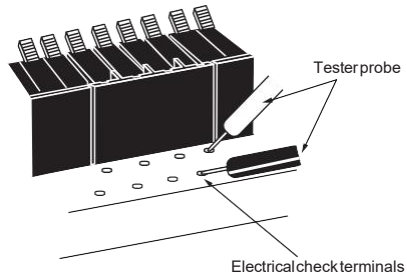

Terms and Conditions Agreement

Read and understand this catalog.

Please read and understand this catalog before purchasing the products. Please consult your OMRON representative if you have any questions or comments.

Warranties.

(a) Exclusive Warranty. Omron's exclusive warranty is that the Products will be free from defects in materials and workmanship for a period of twelve months from the date of sale by Omron (or such other period expressed in writing by Omron). Omron disclaims all other warranties, express or implied.

(b) Limitations. OMRON MAKES NO WARRANTY OR REPRESENTATION, EXPRESS OR IMPLIED, ABOUT NON-INFRINGEMENT, MERCHANTABILITY OR FITNESS FOR A PARTICULAR PURPOSE OF THE PRODUCTS. BUYER ACKNOWLEDGES THAT IT ALONE HAS DETERMINED THAT THE PRODUCTS WILL SUITABLY MEET THE REQUIREMENTS OF THEIR INTENDED USE.

Omron further disclaims all warranties and responsibility of any type for claims or expenses based on infringement by the Products or otherwise of any intellectual property right. (c) Buyer Remedy. Omron's sole obligation hereunder shall be, at Omron's election, to (i) replace (in the form originally shipped with Buyer responsible for labor charges for removal or replacement thereof) the non-complying Product, (ii) repair the non-complying Product, or (iii) repay or credit Buyer an amount equal to the purchase price of the non-complying Product; provided that in no event shall Omron be responsible for warranty, repair, indemnity or any other claims or expenses regarding the Products unless Omron's analysis confirms that the Products were properly handled, stored, installed and maintained and not subject to contamination, abuse, misuse or inappropriate modification. Return of any Products by Buyer must be approved in writing by Omron before shipment. Omron Companies shall not be liable for the suitability or unsuitability or the results from the use of Products in combination with any electrical or electronic components, circuits, system assemblies or any other materials or substances or environments. Any advice, recommendations or information given orally or in writing, are not to be construed as an amendment or addition to the above warranty.

See <http://www.omron.com/global/> or contact your Omron representative for published information.

Limitation on Liability: Etc.

OMRON COMPANIES SHALL NOT BE LIABLE FOR SPECIAL, INDIRECT, INCIDENTAL, OR CONSEQUENTIAL DAMAGES, LOSS OF PROFITS OR PRODUCTION OR COMMERCIAL LOSS IN ANY WAY CONNECTED WITH THE PRODUCTS, WHETHER SUCH CLAIM IS BASED IN CONTRACT, WARRANTY, NEGLIGENCE OR STRICT LIABILITY.

Further, in no event shall liability of Omron Companies exceed the individual price of the Product on which liability is asserted.

Suitability of Use.

Omron Companies shall not be responsible for conformity with any standards, codes or regulations which apply to the combination of the Product in the Buyer's application or use of the Product. At Buyer's request, Omron will provide applicable third party certification documents identifying ratings and limitations of use which apply to the Product. This information by itself is not sufficient for a complete determination of the suitability of the Product in combination with the end product, machine, system, or other application or use. Buyer shall be solely responsible for determining appropriateness of the particular Product with respect to Buyer's application, product or system. Buyer shall take application responsibility in all cases.

NEVER USE THE PRODUCT FOR AN APPLICATION INVOLVING SERIOUS RISK TO LIFE OR PROPERTY OR IN LARGE QUANTITIES WITHOUT ENSURING THAT THE SYSTEM AS A WHOLE HAS BEEN DESIGNED TO ADDRESS THE RISKS, AND THAT THE OMRON PRODUCT(S) IS PROPERLY RATED AND INSTALLED FOR THE INTENDED USE WITHIN THE OVERALL EQUIPMENT OR SYSTEM.

Programmable Products.

Omron Companies shall not be responsible for the user's programming of a programmable Product, or any consequence thereof.

Performance Data.

Data presented in Omron Company websites, catalogs and other materials is provided as a guide for the user in determining suitability and does not constitute a warranty. It may represent the result of Omron's test conditions, and the user must correlate it to actual application requirements. Actual performance is subject to the Omron's Warranty and Limitations of Liability.

Change in Specifications.

Product specifications and accessories may be changed at any time based on improvements and other reasons. It is our practice to change part numbers when published ratings or features are changed, or when significant construction changes are made. However, some specifications of the Product may be changed without any notice. When in doubt, special part numbers may be assigned to fix or establish key specifications for your application. Please consult with your Omron's representative at any time to confirm actual specifications of purchased Product.

Errors and Omissions.

Information presented by Omron Companies has been checked and is believed to be accurate; however, no responsibility is assumed for clerical, typographical or proofreading errors or omissions.

2017.4

In the interest of product improvement, specifications are subject to change without notice.

OMRON Corporation
Industrial Automation Company

<http://www.ia.omron.com/>

(c) Copyright OMRON Corporation 2017 All Right Reserved.