

3-wire type All-metal Proximity Sensors

ED Series



Detecting distance twice that of conventional sensors

When the target material is aluminum, the detecting distance is 20 mm **0.79"** maximum.
(With M30, non-shielded type)

ED-118M (M18, shielded type)

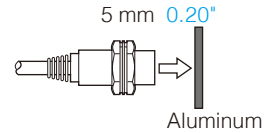

Conventional sensor (M18, shielded type)

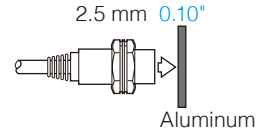

Built-in stability and operation indicators

Output operation indicator (red) and stable operation indicator (green) make adjustments between the sensor and workpiece simple.

Flexible cable

The cable is connected to the sensor head with a highly flexible joint that can be bent without resulting cable damage.

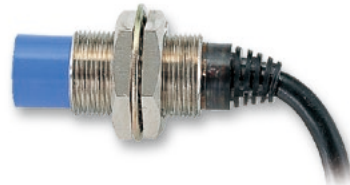

ASK KEYENCE

1-888-KEYENCE
www.keyence.com/ASKG



FREE DOWNLOAD

www.keyence.com/DLG

Free downloads for product and technical support are readily available in one convenient location

Applications

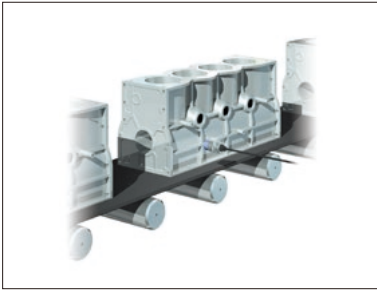

Detecting engine blocks



Detecting aluminum window sashes

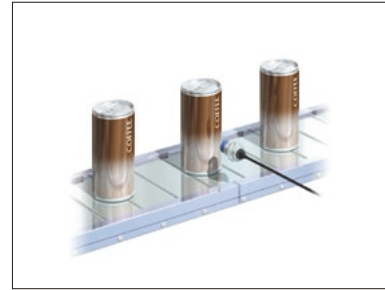

Detecting aluminum cans

Specifications

Type		Shielded		Non-shielded	
Shape		Threaded type			
		M18	M30	M18	M30
Model	NPN	ED-118M	ED-130M	ED-118U	ED-130U
Appearance					
Detecting distance		5 mm 0.20" ±15%	11 mm 0.43" ±15%		20 mm 0.79" ±15%
Detectable object		All metals ¹			
Standard target (aluminum, t=1 mm 0.04")		18 x 18 mm 0.71"	30 x 30 mm 1.18"	50 x 50 mm 1.97"	70 x 70 mm 2.76"
Hysteresis		15% max. of detecting distance			
Response frequency		100 Hz	150 Hz	200 Hz	150 Hz
Operation mode		N.O.			
Indicators		Operation indicator: Red LED, Stable operation indicator: Green LED			
Temperature fluctuation		±20% max. of detecting distance at 23°C (73.4°F), within 0 to 50°C (32 to 122°F)			
Control output		NPN open collector 100 mA max. (40 V max.), Residual voltage: 1 V max.			
Protection circuit		Reversed polarity, surge absorber			
Power supply		12 to 24 VDC±10%, Ripple (P-P) 10% max.			
Current consumption		35 mA max.			
Enclosure rating		IP67			
Ambient temperature		0 to 50°C (32 to 122°F), No freezing			
Relative humidity		35 to 95%, No condensation			
Vibration resistance		10 to 55 Hz, 1.5 mm 0.06" double amplitude in X, Y, and Z directions, 2 hours			
Shock resistance		1000 m/s ² 3280.8' in X, Y, and Z directions, 3 times respectively			
Housing		Nickel-plated brass			
Weight (including 2-m 6.6' cable and nuts)		Approx. 150 g	Approx. 300 g	Approx. 140 g	Approx. 270 g

1. When detecting ferrous metals, the detecting distance may decrease.

New Products

Fiberoptic Sensors

Photoelectric Sensors

Proximity Sensors

Safety Equipment

Flow/Pressure/Temperature

Measurement Sensors

Controls

Static Eliminators

Vision Systems

Marking Equipment

Code Readers

Handheld Mobile Computers

Microscopes

Projector/3D Measurement Systems



Output Circuits

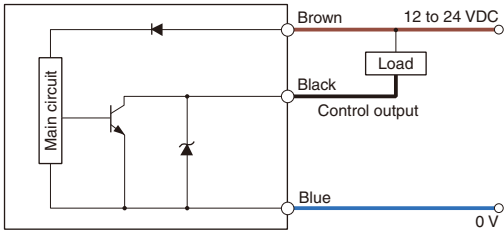

Characteristics

Detecting range (Typical)

ED-118M

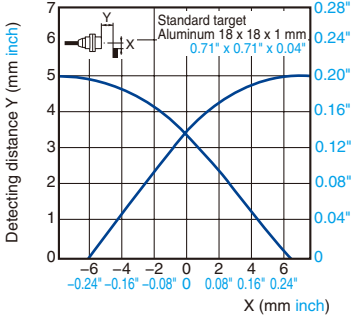

ED-130M

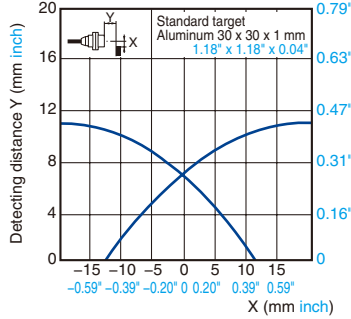

ED-118U

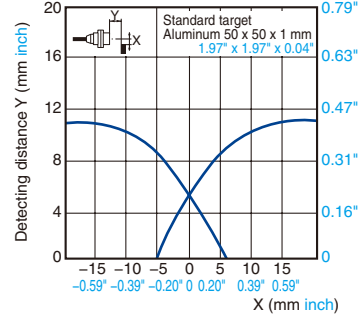

ED-130U

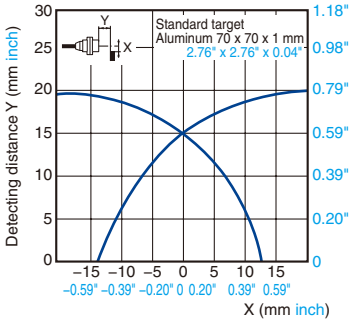

Detecting distance vs. size and target material (Typical)

Iron: SS41, Stainless steel: SUS304, Brass: BS (C3601), Aluminum: Al (A5052), Copper: CU (C1100)

ED-118M

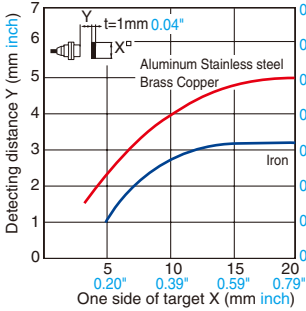

ED-130M

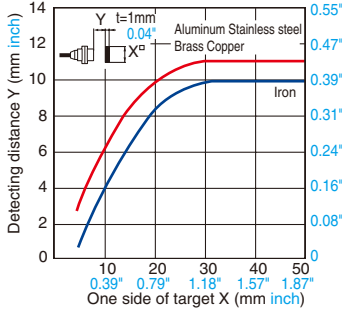

Detecting distance vs. size and target material (Typical)

Iron: SS41, Stainless steel: SUS304, Brass: BS (C3801), Aluminum: Al (A5052), Copper: CU (C1100)

ED-118U

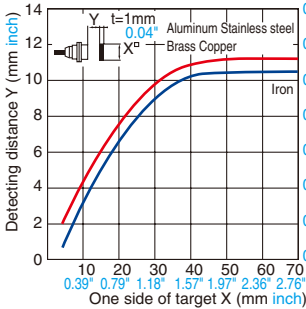

ED-130U

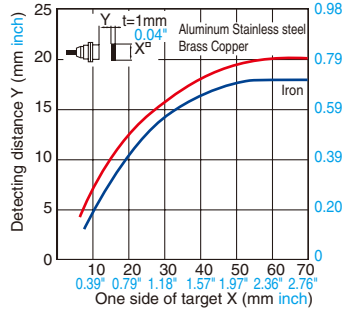

New Products

Fiberoptic Sensors

Photoelectric Sensors

Proximity Sensors

Safety Equipment

Flow/Pressure/Temperature

Measurement Sensors

Controls

Static Eliminators

Vision Systems

Marking Equipment

Code Readers

Handheld Mobile Computers

Microscopes

Projector/3D Measurement Systems



Hints on Correct Use

Mounting

When mounting the sensor, insert the attached toothed washer. Do not tighten beyond the torque specified in the following table.

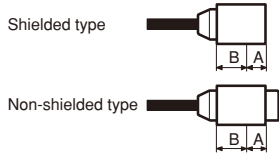

Model	Dimension A (mm inch)	Tightening torque	
		at A	at B
ED-118M	7 0.28"	50 N·m	60 N·m
ED-118U			
ED-130M	12 0.47"	120 N·m	180 N·m
ED-130U			

Surrounding metal

Shielded-type sensors can be flush-mounted in a metal base. Sensors of the non-shielded type should be mounted according to the guidelines below in order to minimize interference from the surrounding metal.

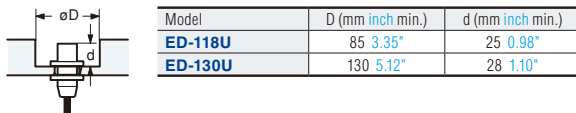

Interference

When installing 2 or more sensors of the same model face-to-face or in parallel, separate them by the distance specified in the following table to prevent interference.

Model	Distance	Parallel (mm inch min.)
	Face-to-face (mm inch min.)	
ED-118M	38 1.50"	27 1.06"
ED-130M	74 2.91"	52 2.05"
ED-118U	105 4.13"	72 2.83"
ED-130U	183 7.20"	135 5.31"

Wiring

Limit the length of extension to within 50 m 164.0'. The sensor cable (coaxial cable) must not be extended or cut.

Dimensions

Unit: mm inch

ED-118M

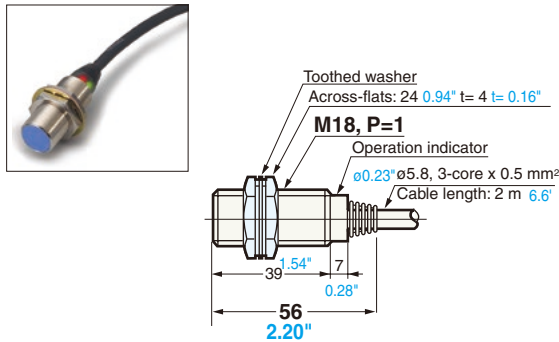

ED-130M

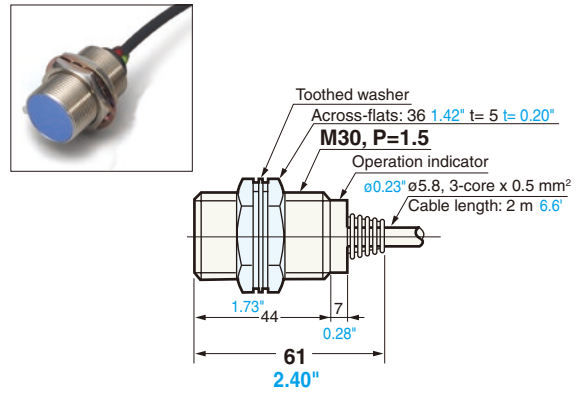

ED-118U

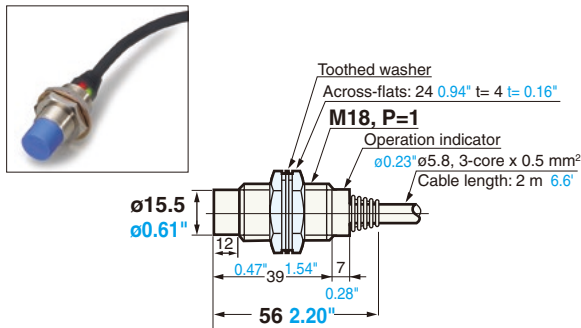

ED-130U

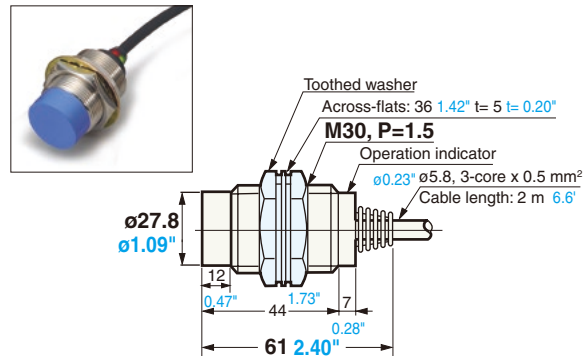

New Products

Fiberoptic Sensors

Photoelectric Sensors

Proximity Sensors

Safety Equipment

Flow/Pressure/Temperature

Measurement Sensors

Controls

Static Eliminators

Vision Systems

Marking Equipment

Code Readers

Handheld Mobile Computers

Microscopes

Projector/3D Measurement Systems

